

产品规格书

PRODOCUT SPECIFICATION

客户名称

CUSTOMER : _____

产品名称

通用型系列片式容陶瓷电容器

PART NAME: _____ **Multilayer Chip Ceramic Capacitors**

规格

SPECIFICATION: _____ **1005~1812TYPE**

版本

VERSION: _____

日期

DATE OF ISSUE: _____

制 造 MANUFACTURER			客 户 CUSTOMER		
拟制 DESIGN	审核 CHECK	批准 APPROVAL	检验 INSPECTOR	审核 CHECK	批准 APPROVAL

序号 No	目 录 TABLE OF CONTENTS
1	应用范围 Application
2	型号表示法 Ordering Code
3	产品结构 Product Structure
4	容量范围及其电压 Capacitance Range and Operating Voltage
5	可靠性测试方法 Reliability Test Methods
6	包装 Package
7	储存方法 Storage Methods
8	使用前的注意事项 Precautions Before Use

■通用型系列片式陶瓷电容器
General series of ceramic chip capacitors

◆特征
Feature

*叠层独石结构，具有高可靠性能

There is high reliability on monolithic structure of laminated layers.

*具有优良的焊接与耐焊性能，适用于回流焊接与波峰焊接

And its character of excellent soldering ability and

soldering resistance ability is suitable for reflow soldering and peak soldering.

*具有较高的容量且容量性能稳定

It includes high and stable capacitance.

*高频类：此类介质材料的电容器为 I 类电容器。其中 C0G、C0H 电容器电性能最稳定，几乎不随温度、电压和时间的变化而变化，适用于低损耗，稳定性要求高的高频电路。

High Frequency Type: This kind of dielectric material is considered as Class I capacitor. C0G and C0H capacitors have the most stable electrical performance, which almost does not change with the change of temperature, voltage or time, they are suitable for the low-loss and high stability requirement circuits.

*X7R、X7S、X7T、X6S、X6T、X5R、：此类介质材料的电容器为 II 类电容器，具有较高的介电常数，容量比 I 类电容器高，具有较稳定的温度特性，适用于容量范围广，稳定性要求不高的电路中，如隔直、耦合、旁路、鉴频等电路中。

X7R、X5R、X7S、X6S: X7R、X5R、X7S、X6S material is a kind of material has high dielectric constant. The capacitor made of this kind material is considered as Class II capacitor whose capacitance is higher than that of class I. These capacitors are classified as having a semi-stable temperature characteristic and used over a wide temperature range, such in these kinds of circuits, DC-blocking, decoupling, bypassing, frequency discriminating etc.

执行标准：GB/T 21041-2007 GB/T 21042-2007

Executive Standard: GB/T 21041-2007 GB/T 21042-2007

◆应用
Application

*应用于各种滤波、耦合、谐振、旁路、高频电子线路

It is suitable for all kinds of filter, coupled, harmonic vibration, bypassing and high frequency circuits.

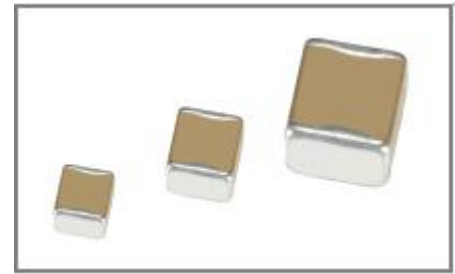

◆型号表示法
How To Order

0805			CG		102		J		500		N		T		
尺寸规格 Size Code			标称容量 Nominal Capacitance		额定电压 Rated Voltage 单位(unit): V		包装方式 Package Styles								
尺寸规格 Size Code	长×宽 (L×W) inch	长×宽 (L×W) mm	表示方式 Express Method	实际值 Actual Value	表示方式 Express Method	实际值 Actual Value	表示方式 Express Method	包装方式 Package Styles							
1005	0.01×0.005	0.40×0.20	0R5	0.5	6R3	6.3	B	散包装 Bulk Bag							
0201	0.02×0.01	0.60×0.30	1R0	1.0	500	50×10 ⁰	T	编带包装 Taping Package							
0402	0.04×0.02	1.00×0.50	102	10×10 ²	201	20×10 ¹									
0603	0.06×0.03	1.60×0.80	注：头两位数字为有效数字，第三位数字为0的个数；R为小数点。 Note: the first two digits are significant; third digit denotes number of zeros; R=decimal point.		注：头两位数字为有效数字，第三位数字为0的个数；R为小数点。 Note: the first two digits are significant; third digit denotes number of zeros; R=decimal point.										
0805	0.08×0.05	2.00×1.25													
1206	0.12×0.06	3.20×1.60													
1210	0.12×0.10	3.20×2.50													
1808	0.18×0.08	4.50×2.00													
1812	0.18×0.12	4.50×3.20													
介质种类 Dielectric Code			容量误差 Capacitance Tolerance		端头材料 Terminal Material Styles										
介质种类 Dielectric Code	介质材料 Dielectric		代码 Code	误差 Tolerance	备注 Note		端头类别 Termination Styles	表示方式 Express Method							
CG	C0G		A	±0.05pF	A、B、C、D级误差适用于容量≤10pF的产品。 These Capacitance tolerance A, B, C, D are just applicable the capacitance that equals to or less than 10pF.	三层电镀端头 Nickel Barrier Termination	N								
X	X5R		B	±0.10pF											
B	X7R		C	±0.25pF											
BS	X7S		D	±0.50pF											
BT	X7T		F	±1%											
DS	X6S		G	±2%											
DT	X6T		J	±5%											
			K	±10%											
			M	±20%											

◆产品结构
Product Structure

序号 NO	名称 Name
①	陶瓷介质 Ceramic dielectric
②	内电极 Inner electrode
③	外电极 Substrate electrode
④	镍层 Nickel Layer
⑤	锡层 Tin Layer

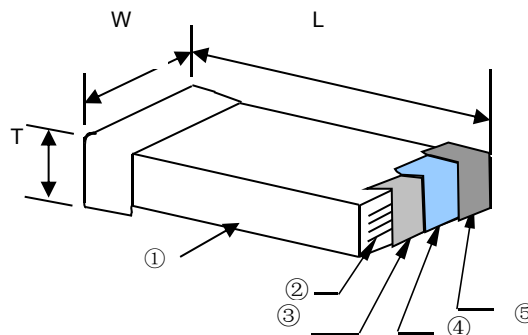

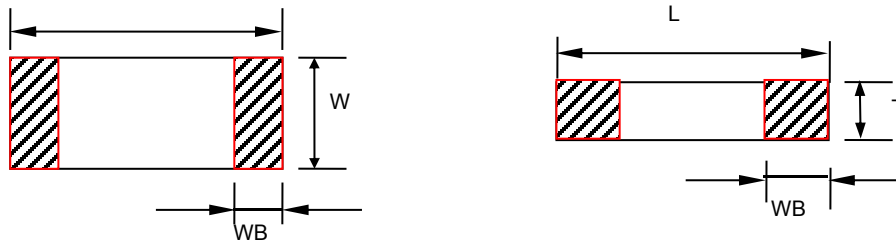
◆产品尺寸
Product Dimensions

型号 Type		尺寸 Dimensions (mm)				特别说明 Special Instructions
英制表示 British expression	公制表示 Metric expression	L	W	T	WB	
1005	0402	0.4±0.02	0.2±0.02	0.2±0.02	0.1±0.03	All
0201	0603	0.6±0.03	0.3±0.03	0.3±0.03	0.15±0.05	C<0.1uF
		0.6±0.05	0.3±0.05	0.3±0.05	0.15±0.05	0.1uF≤C<1uF
		0.6±0.10	0.3±0.10	0.3±0.10	0.15±0.05	C≥1uF
0402	1005	1.00±0.05	0.50±0.05	0.50±0.05	0.25±0.05	C<0.22uF
		1.00±0.15	0.50±0.15	0.50±0.15	0.25±0.05	0.22uF≤C<1uF
		1.00±0.20	0.50±0.20	0.50±0.20	0.25±0.05	C≥1uF
0603	1608	1.60±0.10	0.80±0.10	0.80±0.10	0.35±0.20	C<1uF
		1.60±0.20	0.80±0.20	0.80±0.20	0.35±0.20	C≥1uF
0805	2012	2.00±0.20	1.25±0.20	0.80±0.20	0.50±0.20	C<0.47μF
		2.00±0.20	1.25±0.20	1.25±0.20	0.50±0.20	C≥0.47μF
1206	3216	3.20±0.30	1.60±0.30	0.80±0.20	0.60±0.30	C≤220nF
		3.20±0.30	1.60±0.30	1.00±0.20	0.60±0.30	220nF<C<1μF
		3.20±0.30	1.60±0.30	1.60±0.30	0.60±0.30	C≥1μF
1210	3225	3.20±0.30	2.50±0.30	≤2.80	0.60±0.30	All
1808	4520	4.50±0.40	2.00±0.20	≤2.20	0.60±0.30	All
1812	4532	4.50±0.40	3.20±0.30	≤3.50	0.60±0.30	All

备注：1、产品具体厚度“T” 查阅本承认书中“容量范围及其电压”。2、可根据客户的特殊要求设计符合客户需求的产品。

Note: 1、The specific thickness of the product can read "capacity range and voltage" in this approval sheet

2、We can design according to customer special requirements

◆温度系数/特性 Temperature Coefficient /Characteristics

介质种类 Dielectric	参考温度点 Reference Temperature Point	标称温度系数 Temperature Coefficient	工作温度范围 Operation Temperature Range
C0G	20°C	0±30 ppm/°C	-55°C~125°C
X7R	20°C	±15%	-55°C~125°C
X7S	20°C	±22%	-55°C~125°C
X7T	20°C	-33%~+22%	-55°C~125°C
X6S	20°C	±22%	-55°C~105°C
X6T	20°C	-33%~+22%	-55°C~105°C
X5R	20°C	±15%	-55°C~85°C

备注：I类电容器标称温度系数和允许偏差是采用温度在 20°C 和 85°C 之间的电容量变化来确定的，而 II 类电容器标称温度系数是按照工作温度范围之间的电容量相对 20°C 的电容量变化来确定的。

Note: Nominal temperature coefficient and allowed tolerance of class I are decided by the changing of the capacitance between 20°C and 85°C. Nominal temperature coefficient of class II are decided by the temperature of 20°C.

◆容量范围及其电压
Capacitance Range and Operating Voltage

*I 类电容器具体电压对应容量及厚度情况列表

A list of the specific voltage-specific capacitors of Class I capacitors

材料 Dielectric	C0G									
	1005 (0.4mm*0.2mm)				0201 (0.6mm*0.3mm)		0402 (1.0mm*0.5mm)		0603 (1.6mm*0.8mm)	
尺寸 Dimension	10V	16V	25V	50V	25V	50V	25V	50V	25V	50V
容量/电压 Capacity/ Voltage	10V	16V	25V	50V	25V	50V	25V	50V	25V	50V
0.1pF	0.2±0.02				0.3±0.03		0.50±0.05		0.80±0.10	
0.2pF										
0.5pF										
1pF										
1.2pF										
1.5pF										
1.8pF										
2.0pF										
2.2pF										
2.7pF										
3.0pF										
3.3pF										
3.6pF										
3.9pF										
4.7pF										
5.0pF										
5.6pF										
6.8pF										
8.0pF										
8.2pF										
10pF	0.3±0.03		0.3±0.03		0.50±0.05		0.50±0.05			
12pF	0.3±0.03		0.3±0.03		0.50±0.05		0.50±0.05			
15pF	0.3±0.03		0.3±0.03		0.50±0.05		0.50±0.05			
18pF	0.3±0.03		0.3±0.03		0.50±0.05		0.50±0.05			
22pF	0.3±0.03		0.3±0.03		0.50±0.05		0.50±0.05			
27pF	0.3±0.03		0.3±0.03		0.50±0.05		0.50±0.05			
33pF	0.3±0.03		0.3±0.03		0.50±0.05		0.50±0.05			
39pF	0.3±0.03		0.3±0.03		0.50±0.05		0.50±0.05			
47pF	0.3±0.03		0.3±0.03		0.50±0.05		0.50±0.05			
56pF	0.3±0.03		0.3±0.03		0.50±0.05		0.50±0.05			
68pF	0.3±0.03		0.3±0.03		0.50±0.05		0.50±0.05			
100pF	0.3±0.03		0.3±0.03		0.50±0.05		0.50±0.05			
120pF	0.3±0.03		0.3±0.03		0.50±0.05		0.50±0.05			
150pF	0.3±0.03		0.3±0.03		0.50±0.05		0.50±0.05			
180pF	0.3±0.03		0.3±0.03		0.50±0.05		0.50±0.05			
220pF	0.3±0.03		0.3±0.03		0.50±0.05		0.50±0.05			
270pF	0.3±0.03		0.3±0.03		0.50±0.05		0.50±0.05			
330pF	0.3±0.03		0.3±0.03		0.50±0.05		0.50±0.05			
390pF	0.3±0.03		0.3±0.03		0.50±0.05		0.50±0.05			
470pF	0.3±0.03		0.3±0.03		0.50±0.05		0.50±0.05			
560pF	0.3±0.03		0.3±0.03		0.50±0.05		0.50±0.05			
680pF	0.3±0.03		0.3±0.03		0.50±0.05		0.50±0.05			
1nF	0.3±0.03		0.3±0.03		0.50±0.05		0.50±0.05			
1.5nF	0.3±0.03		0.3±0.03		0.50±0.05		0.50±0.05			
1.8nF	0.3±0.03		0.3±0.03		0.50±0.05		0.50±0.05			
2.2nF	0.3±0.03		0.3±0.03		0.50±0.05		0.50±0.05			
2.7nF	0.3±0.03		0.3±0.03		0.50±0.05		0.50±0.05			
3.3nF	0.3±0.03		0.3±0.03		0.50±0.05		0.50±0.05			
4.7nF	0.3±0.03		0.3±0.03		0.50±0.05		0.50±0.05			
10nF	0.3±0.03		0.3±0.03		0.50±0.05		0.50±0.05			

备注：1、对应产品设计厚度，单位：mm 2、可根据客户的特殊要求设计符合客户需求的产品

Note: 1、Corresponding product design thickness , unit:mm 2、We can design according to customer special requirements

材料 Dielectric	COG							
尺寸 Dimension	0805 (2.0mm*1.25mm)		1206 (3.2mm*1.6mm)		1210 (3.2mm*2.5mm)		1812 (4.5mm*3.2mm)	
容量/电压 Capacity/ Voltage	25V	50V	25V	50V	25V	50V	25V	50V
0.1pF								
0.22pF								
0.3pF								
0.47pF								
1pF								
1.2pF								
1.5pF								
1.8pF								
2.0pF								
2.2pF								
2.7pF								
3.0pF								
3.3pF								
3.6pF								
3.9pF								
4.7pF								
5.0pF								
5.6pF								
6.8pF								
8.0pF								
8.2pF								
10pF								
12pF								
15pF								
18pF								
22pF								
27pF	0.8±0.20		0.8±0.20					
33pF								
39pF								
47pF								
56pF								
68pF								
100pF								
120pF								
150pF								
180pF								
220pF								
270pF								
330pF								
390pF								
470pF								
560pF								
680pF								
1nF								
1.5nF								
1.8nF								
2.2nF								
2.7nF								
3.3nF								
4.7nF								
6.8nF								
10nF			1.25±0.20					
12nF	1.25±0.20							
22nF								
33nF			1.60±0.30					
47nF								
100nF								

备注：1、对应产品设计厚度，单位：mm 2、可根据客户的特殊要求设计符合客户需求的产品

Note: 1、Corresponding product design thickness , unit:mm 2、We can design according to customer special requirement.

***II 类电容器具体电压对应容量及厚度情况列表**

A list of the specific voltage-specific capacitors of Class II capacitors

尺寸 Dimension	1005 (0.4mm*0.2mm)																
材料 Dielectric	X7R 系列			X7S 系列			X7T 系列			X6S/X6T 系列			X5R 系列				
容量/电压 Capacity/ Voltage	6.3V	10V	16V	6.3V	10V	16V	6.3V	10V	16V	6.3V	10V	16V	6.3V	10V	16V		
120pF	0.2±0.02			0.2±0.02			0.2±0.02			0.2±0.02			0.2±0.02				
180pF																	
220pF																	
270pF																	
330pF																	
390pF																	
470pF																	
560pF																	
680pF																	
1nF																	
1.2nF																	
1.5nF																	
1.8nF																	
2.2nF																	
2.7nF																	
3.3nF																	
3.9nF																	
4.7nF																	
5.6nF																	
6.8nF																	
10nF																	
15nF																	
22nF																	
33nF																	
47nF													0.2±0.02				
68nF																	
100nF																	

尺寸 Dimension	0201 (0.6mm*0.3mm)																								
材料 Dielectric	X7R 系列					X7S 系列					X7T 系列					X6S/X6T 系列					X5R 系列				
容量/电压 Capacity/ Voltage	6.3V	10V	16V	25V	50V	6.3V	10V	16V	25V	50V	6.3V	10V	16V	25V	50V	6.3V	10V	16V	25V	50V	6.3V	10V	16V	25V	50V
120pF	0.3±0.03					0.3±0.03					0.3±0.03					0.3±0.03									
180pF																									
220pF																									
330pF																									
470pF																									
560pF																									
680pF																									
1nF																									
2.2nF	0.3±0.03					0.3±0.03					0.3±0.03					0.3±0.03									
3.9nF																									
4.7nF																									
5.6nF	0.3±0.03					0.3±0.03					0.3±0.03					0.3±0.03									
6.8nF																									
10nF	0.3±0.03					0.3±0.03					0.3±0.03					0.3±0.03									
15nF																									
18nF																									
22nF	0.3±0.03					0.3±0.03					0.3±0.03					0.3±0.03									
33nF																									

备注：1、对应产品设计厚度，单位：mm 2、可根据客户的特殊要求设计符合客户需求的产品

Note: 1、Corresponding product design thickness , unit:mm 2、We can design according to customer special requirement

尺寸 Dimension	0201 (0.6mm*0.3mm)																								
材料 Dielectric	X7R 系列					X7S 系列					X7T 系列					X6S/X6T 系列					X5R 系列				
容量/电压 Capacity/ Voltage	6.3V	10V	16V	25V	50V	6.3V	10V	16V	25V	50V	6.3V	10V	16V	25V	50V	6.3V	10V	16V	25V	50V	6.3V	10V	16V	25V	50V
47nF																									
56nF																									
68nF																									
100nF																									
220nF																									
330nF																									
470nF																									
1μF																									
2.2μF																									

尺寸 Dimension	0402 (1.0mm*0.5mm)																								
材料 Dielectric	X7R 系列					X7S 系列					X7T 系列					X6S/X6T 系列					X5R 系列				
容量/电压 Capacity/ Voltage	6.3V	10V	16V	25V	50V	6.3V	10V	16V	25V	50V	6.3V	10V	16V	25V	50V	6.3V	10V	16V	25V	50V	6.3V	10V	16V	25V	50V
330pF																									
470pF																									
560pF																									
680pF																									
1nF																									
2.2nF																									
3.9nF																									
4.7nF																									
5.6nF																									
6.8nF																									
10nF																									
15nF																									
18nF																									
22nF																									
33nF																									
47nF																									
56nF																									
68nF																									
100nF																									
220nF																									
330nF																									
470nF																									
680nF																									
1μF																									
2.2μF																									
4.7μF																									
6.8μF																									
10μF																									

备注：1、对应产品设计厚度，单位：mm 2、可根据客户的特殊要求设计符合客户需求的产品

Note: 1、Corresponding product design thickness , unit:mm 2、We can design according to customer special requirement

尺寸 Dimension	0603 (1.6mm*0.8mm)																								
	X7R 系列					X7S 系列					X7T 系列					X6S/X6T 系列					X5R 系列				
材料 Dielectric																									
容量/电压 Capacity/ Voltage	6.3V	10V	16V	25V	50V	6.3V	10V	16V	25V	50V	6.3V	10V	16V	25V	50V	6.3V	10V	16V	25V	50V	6.3V	10V	16V	25V	50V
330pF	0.8±0.1					0.8±0.1					0.8±0.1					0.8±0.1									
470pF																									
560pF																									
680pF																									
1nF																									
2.2nF																									
3.9nF																									
4.7nF																									
5.6nF																									
6.8nF																									
10nF																									
15nF																									
18nF																									
22nF																									
33nF																									
47nF																									
56nF																									
68nF																									
100nF																									
220nF																									
330nF																									
470nF																0.8±0.1									
680nF																					0.8±0.2				
1μF	0.8±0.2					0.8±0.2					0.8±0.2					0.8±0.2					0.8±0.2				
2.2 μF	0.8±0.2					0.8±0.2					0.8±0.2					0.8±0.2									
3.3 μF	0.8±0.2					0.8±0.2					0.8±0.2					0.8±0.2					0.8±0.2				
4.7 μF																0.8±0.2									
6.8 μF											0.8±0.2														
10 μF											0.8±0.2														
15 μF																0.8±0.2									
22 μF																0.8±0.2									
47μF																					0.8±0.2				

尺寸 Dimension	0805 (2.0mm*1.25mm)																								
	X7R 系列					X7S 系列					X7T 系列					X6S/X6T 系列					X5R 系列				
材料 Dielectric																									
容量/电压 Capacity/ Voltage	6.3V	10V	16V	25V	50V	6.3V	10V	16V	25V	50V	6.3V	10V	16V	25V	50V	6.3V	10V	16V	25V	50V	6.3V	10V	16V	25V	50V
330pF	0.8±0.2					0.8±0.2					0.8±0.2					0.8±0.2									
470pF																									
560pF																									
680pF																									
1nF																									
2.2nF																									
3.9nF																									
4.7nF																									
5.6nF																									
6.8nF																									
10nF																									
15nF																									

备注：1、对应产品设计厚度，单位：mm 2、可根据客户的特殊要求设计符合客户需求的产品。

备注：1、对应产品设计厚度，单位：mm 2、可根据客户的特殊要求设计符合客户需求的产品。

Note: 1、Corresponding product design thickness , unit:mm 2、We can design according to customer special requirement

尺寸 Dimension	1206 (3.2mm*1.6mm)																								
	X7R 系列					X7S 系列					X7T 系列					X6S/X6T 系列					X5R 系列				
材料 Dielectric	6.3V	10V	16V	25V	50V	6.3V	10V	16V	25V	50V	6.3V	10V	16V	25V	50V	6.3V	10V	16V	25V	50V	6.3V	10V	16V	25V	50V
容量/电压 Capacity/ Voltage																									
3.3μF	1.6±0.3					1.6±0.3					1.6±0.3					1.6±0.3					1.6±0.3				
4.7μF																									
6.8μF																									
10μF																									
15μF	1.6±0.3					1.6±0.3					1.6±0.3					1.6±0.3									
22μF	1.6±0.3					1.6±0.3					1.6±0.3					1.6±0.3									
47μF											1.6±0.3					1.6±0.3									
100μF											1.6±0.3					1.6±0.3									

尺寸 Dimension	1210 (3.2mm*2.5mm)																								
	X7R 系列					X7S 系列					X7T 系列					X6S/X6T 系列					X5R 系列				
材料 Dielectric	6.3V	10V	16V	25V	50V	6.3V	10V	16V	25V	50V	6.3V	10V	16V	25V	50V	6.3V	10V	16V	25V	50V	6.3V	10V	16V	25V	50V
容量/电压 Capacity/ Voltage																									
330pF	1.25±0.2					1.25±0.2					1.25±0.2					1.25±0.2									
470pF																									
560pF																									
680pF																									
1nF																									
2.2nF																									
3.9nF																									
4.7nF																									
5.6nF																									
6.8nF																									
10nF	1.4±0.2					1.4±0.2					1.4±0.2					1.4±0.2									
220nF																									
330nF	1.6±0.3					1.6±0.3					1.6±0.3					1.6±0.3									
470nF																									
680nF																									
1μF																									
2.2μF	2.5±0.3					2.5±0.3					2.5±0.3														
3.3μF																									
4.7μF	2.5±0.3					2.5±0.3					2.5±0.3					2.5±0.3		1.8±0.3							
6.8μF																									
10μF	2.5±0.3					2.5±0.3					2.5±0.3					2.5±0.3									
15μF																									
22μF	2.5±0.3					2.5±0.3					2.5±0.3					2.5±0.3									
47μF											2.5±0.3					2.5±0.3									
100μF																2.5±0.3									

备注：1、对应产品设计厚度，单位：mm 2、可根据客户的特殊要求设计符合客户需求的产品。

Note: 1、Corresponding product design thickness , unit:mm 2、We can design according to customer special requirement

尺寸 Dimension	1808 (4.5mm*2.0mm)																													
	X7R 系列					X7S 系列					X7T 系列					X6S/X6T 系列					X5R 系列									
材料 Dielectric	6.3V	10V	16V	25V	50V	6.3V	10V	16V	25V	50V	6.3V	10V	16V	25V	50V	6.3V	10V	16V	25V	50V	6.3V	10V	16V	25V	50V	6.3V	10V	16V	25V	50V
容量/电压 Capacity/ Voltage																														
330pF	1.6±0.3																													
470pF																														
560pF																														
680pF																														
1nF																														
2.2nF																														
3.9nF																														
4.7nF																														
5.6nF																														
6.8nF																														
10nF																														
15nF																														
18nF																														
22nF																														
33nF																														
47nF																														
56nF																														
68nF																														
100nF																														
220nF																														
330nF																														
470nF																														
680nF																														
1μF																														
2.2μF	1.6±0.3					1.6±0.3					1.6±0.3					1.6±0.3					1.6±0.3									
3.3μF	1.6±0.3					1.6±0.3					1.6±0.3					1.6±0.3					1.6±0.3									
4.7μF																					1.6±0.3									
6.8μF																														

尺寸 Dimension	1812 (4.5mm*3.2mm)																													
	X7R 系列					X7S 系列					X7T 系列					X6S/X6T 系列					X5R 系列									
材料 Dielectric	6.3V	10V	16V	25V	50V	6.3V	10V	16V	25V	50V	6.3V	10V	16V	25V	50V	6.3V	10V	16V	25V	50V	6.3V	10V	16V	25V	50V	6.3V	10V	16V	25V	50V
容量/电压 Capacity/ Voltage																														
330pF	1.60±0.20																													
470pF																														
560pF																														
680pF																														
1nF																														
2.2nF																														
3.9nF																														
4.7nF																														
5.6nF																														
6.8nF																														
10nF																														
15nF																														
18nF																														
22nF																														
33nF																														
47nF																														
56nF																														
68nF																														

100nF					
220nF					

尺寸 Dimension	1812 (4.5mm*3.2mm)																								
材料 Dielectric	X7R 系列					X7S 系列					X7T 系列					X6S/X6T 系列					X5R 系列				
容量/电压 Capacity/ Voltage	6.3 V	10V	16V	25V	50V	6.3V	10V	16V	25V	50V	6.3V	10V	16V	25V	50V	6.3V	10V	16V	25V	50V	6.3V	10V	16V	25V	50V
330nF	1.60±0.20					1.60±0.20					1.60±0.20					1.60±0.20					1.60±0.20				
470nF																									
680nF																									
1μF	2.0±0.20					2.0±0.20					2.0±0.20					2.0±0.20					2.0±0.20				
2.2μF																									
3.3μF																									
4.7μF																									
6.8μF																									

备注：1、【】对应容量的通用厚度，单位：mm 2、可根据客户的特殊要求设计符合客户需求的产品

Note: 1、【】 General thickness corresponds to the capacity, unit: mm2、We can design according to the customer requirements

◆可靠性测试

Reliability Test

项目 Item	技术规格 Technical Specification		测试方法 Test Method and Remarks		
容量 Capacitance	I类 Class I	应符合指定的误差级别 Should be within the specified tolerance.	标称容量 Capacitance	测试频率 Measuring Frequency	测试电压 Measuring Voltage
			≤1000pF	1MHz±10%	1.0±0.2Vrms
			>1000 pF	1KHz±10%	
	II类 Class II	应符合指定的误差级别 Should be within the specified tolerance.	测试温度：25℃±3℃ Test Temperature: 25℃±3℃ C≤10μF: 测试频率：1KHz±10% Test Frequency: 1KHz±10% 测试电压：1.0±0.2Vrms Test Voltage: 1.0±0.2Vrms C>10μF 测试频率：120±24 Hz Test Frequency: 120±24 Hz 测试电压：0.5±0.1Vrms Test Voltage: 0.5±0.1Vrms		
绝缘电阻 (IR) Insulation Resistance	I类 Class I	C≤10 nF, Ri≥50000MΩ C>10 nF, Ri·CR≥500S	测试电压：额定电压（最高 500V） 测试时间：60±5 秒 测试湿度：≤75% 测试温度：25℃±3℃ 测试充放电电流：≤50mA Measuring Voltage: Rated Voltage (Max 500V) Duration: 60±5s Test Humidity: ≤75% Test Temperature: 25℃±3℃ Test Current: ≤50mA		
	II类 Class II	C≤25 nF, Ri≥10000MΩ C>25 nF, Ri·CR>100S			
	注：S=Q·F				
损耗角正切 (DF, tanδ) Dissipation Factor	I类 Class I	DF	标称容量 Capacitance	测试频率 Measuring Frequency	测试电压 Measuring Voltage
		≤1/ (400+20C)	C<30 pF	1MHz±10% (C>1000 pF, 1KHz±10%)	1.0±0.2Vrms
		≤0.1%	C≥30pF		

项目 Item	技术规格 Technical Specification							测试方法 Test Method and Remarks		
损耗角正切 (DF, tanδ) Dissipation Factor	II类 Class II	电压	DF($\times 10^{-4}$)	1005	0201	0402	0603	0805	1206 及 上	C \leq 10 μ F 测试频率: 1KHz \pm 10% 测试电压: 1.0 \pm 0.2Vrms Test Frequency: 1KHz \pm 10% Test Voltage: 1.0 \pm 0.2Vrms C $>$ 10 μ F X7R、X5R、X7T、 X6S 测试频率: 120 \pm 24 Hz 测试电 压: 0.5 \pm 0.1Vrms Test Frequency: 120 \pm 24Hz Test Voltage: 0.5 \pm 0.1Vrms
		50V	≤ 250	---	---	≤ 10 nF	$<$ 100nF	---	≤ 680 nF	
			≤ 350	---	≤ 3.3 nF	≤ 47 nF	$<$ 470nF	≤ 1 μ F	≤ 2.2 μ F	
			≤ 500	---	≤ 10 nF	≤ 0.1 μ F	---	---	---	
			≤ 750	---	---	---	---	≤ 2.2 μ F	≤ 4.7 μ F	
			≤ 1000	---	---	---	≤ 2.2 μ F	≤ 10 μ F	≤ 10 μ F	
		25V	≤ 250	---	---	≤ 10 nF	$<$ 100nF	---	≤ 680 nF	
			≤ 350	---	≤ 3.3 nF	≤ 47 nF	$<$ 470nF	≤ 1 μ F	---	
			≤ 500	---	≤ 10 nF	≤ 0.22 μ F	---	---	---	
			≤ 750	---	$>$ 10nF	---	---	≤ 2.2 μ F	≤ 10 μ F	
			≤ 1000	---	≤ 100 nF	≤ 2.2 μ F	≤ 10 μ F	≤ 22 μ F	≤ 22 μ F	
		16V	250	---	---	≤ 10 nF	$<$ 100nF	---	≤ 680 nF	
			≤ 350	≤ 1 nF	≤ 3.3 nF	≤ 47 nF	$<$ 470nF	≤ 1 μ F	---	
			≤ 500	---	≤ 15 nF	≤ 220 nF	---	---	---	
			≤ 750	≤ 10 nF	≤ 47 nF	---	---	≤ 4.7 μ F	≤ 10 μ F	
			≤ 1000	---	≤ 100 nF	≤ 4.7 μ F	≤ 10 μ F	≤ 22 μ F	≤ 47 μ F	
		10V	≤ 250	---	---	≤ 10 nF	$<$ 100nF	---	≤ 680 nF	
			≤ 350	≤ 1 nF	≤ 3.3 nF	≤ 47 nF	$<$ 470nF	≤ 1 μ F	---	
			≤ 500	---	≤ 15 nF	≤ 220 nF	---	---	---	
			≤ 750	≤ 10 nF	≤ 100 nF	---	---	≤ 2.2 μ F	≤ 10 μ F	
			≤ 1000	---	≤ 2.2 μ F	≤ 10 μ F	≤ 22 μ F	≤ 47 μ F	≤ 47 μ F	
		≤ 6.3 V	≤ 250	---	---	≤ 10 nF	$<$ 100nF	---	≤ 680 nF	
			≤ 350	≤ 1 nF	≤ 3.3 nF	47nF	$<$ 470nF	≤ 1 μ F	---	
			≤ 500	---	≤ 15 nF	≤ 220 nF	---	---	---	
≤ 750	≤ 10 nF		≤ 47 nF	---	---	≤ 2.2 μ F	≤ 10 μ F			
≤ 1000	≤ 100 nF		≤ 2.2 μ F	≤ 10 μ F	≤ 47 μ F	≤ 47 μ F	≤ 100 μ F			
介质耐电强度 (DW) Dielectric Withstanding Voltage	不应有介质被击穿或损伤 No breakdown or damage.				测量电压: I类: 300%额定电压 II类: 250%额定电压 时间: 1~5秒 充/放电电流: 不应超过 50mA (这部分说明不包括中高压 MLCC) Measuring Voltage: Class I :300% Rated voltage Class II :250% Rated voltage Duration: 1~5s Charge/ Discharge Current: 50mA max. (This method excludes high-voltage MLCC)					
可焊性 Solderability	上锡率应大于 95% 外观: 无可见损伤. At least 95% of the terminal electrode is covered by new solder. Visual Appearance: No visible damage.				将电容在 80~120℃的温度下预热 10~30 秒. Preheating conditions:80 to 120℃; 10~30s.					
					有铅焊料: (Sn/Pb: 63/37) 浸锡温度: 235 \pm 5℃ 浸锡时间: 2 \pm 0.5s Pb-Sn soldering Solder Temperature: 235 \pm 5℃ Duration: 2 \pm 0.5s			无铅焊料: 浸锡温度: 245 \pm 5℃ 浸锡时间: 2 \pm 0.5s Lead-free soldering Solder Temperature: 245 \pm 5℃ Duration: 2 \pm 0.5s		

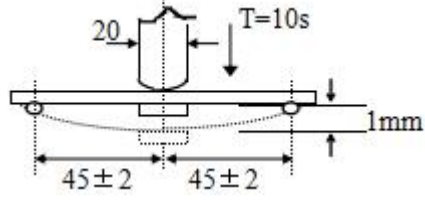
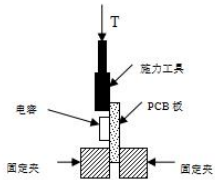
项目 Item	技术规格 Technical Specification		测试方法 Test Method and Remarks					
耐焊接热 Resistance to Soldering Heat	项目 Item	I类	将电容在 100~200°C 的温度下预热 60-120 秒。 浸锡温度: 265±5°C 浸锡时间: 10±1s 然后取出溶剂清洗干净, 在 10 倍以上的显微镜底下观察。 试验后放置时间: 24±2 小时。 放置条件: 室温 Preheating conditions: 100 to 200°C; 60-120 seconds. Solder Temperature: 265±5°C Duration: 10±1s Clean the capacitor with solvent and examine it with a 10X(min.) microscope. Recovery Time: 24±2h. Recovery condition: Room temperature					
	ΔC/C	≤±2.5%或±0.25pF, 取较大值 ≤ ± 2.5% or ± 0.25PF, whichever is larger		±15%				
	DF	同初始标准 Same to initial value.						
	IR	同初始标准 Same to initial value.						
	外观: 无可见损伤 上锡率: ≥95% Appearance: No visible damage. At least 95% of the terminal electrode is covered by new solder.							
抗弯曲强度 Resistance to Flexure of Substrate (Bending Strength)	外观: 无可见损伤。 Appearance: No visible damage.		试验基板: PCB 弯曲深度: 1mm 施压速度: 1mm/sec. 单位: mm 应在弯曲状态下进行测量。 Test Board: PCB Warp: 1mm Speed: 1mm/sec. Unit: mm The measurement should be made with the board in the bending position.					
	ΔC/C:	I类: ≤±5%或±0.5pF, 取两者中最大者 II类: ≤±10% Class I: ≤±5%或±0.5pF, whichever is larger. Class II: ≤±10%						
端头结合强度 Termination Adhesion	外观无可见损伤 No visible damage.		如图所示: 慢慢施加一个 T 的力到电容侧面瓷体上, 并保持 60+1 秒。 As shown in the picture, Slowly apply a T force to the porcelain body on the side of the capacitor and hold for 60+1 seconds.					
				<table border="1" data-bbox="893 1310 1133 1467"> <thead> <tr> <th>规格</th> <th>施加力 T</th> </tr> </thead> <tbody> <tr> <td>≤0402</td> <td>2N</td> </tr> <tr> <td>≥0603</td> <td>5N</td> </tr> </tbody> </table> 	规格	施加力 T	≤0402	2N
规格	施加力 T							
≤0402	2N							
≥0603	5N							

温度循环 Temperature Cycle	项目 Item	I类	II类	预处理* (II类) : 上限类别温度, 1 小时 恢复: 24±1h Preheating conditions: up-category temperature, 1h Recovery time: 24±1h 初始测量 Initial Measurement 循环次数: 5 次, 一个循环分以下 4 步: Cycling Times: 5 times, 1 cycle, 4 steps:														
	ΔC/C	≤±1%或±1pF, 取较大值 ≤±1% or ±1pF, whichever is larger	-15% ~+15%															
	外观无可见损伤 No visible damage.																	
<table border="1"> <thead> <tr> <th>阶段 Step</th> <th>温度 (Temperature) (°C)</th> <th>时间 (Time)</th> </tr> </thead> <tbody> <tr> <td>1</td> <td>下限温度 (Low- category temp.): :-55</td> <td>30min</td> </tr> <tr> <td>2</td> <td>常温 (Normal temp.) : +20°C</td> <td>2~3min</td> </tr> <tr> <td>3</td> <td>上限温度 (Up- category temp.) (C0G/X7R/X7T/X7S: +125 X5R:+85 X6S/X6T:+105)</td> <td>30min</td> </tr> <tr> <td>4</td> <td>常温 (Normal temp.) : +20°C</td> <td>2~3min</td> </tr> </tbody> </table>				阶段 Step	温度 (Temperature) (°C)	时间 (Time)	1	下限温度 (Low- category temp.): :-55	30min	2	常温 (Normal temp.) : +20°C	2~3min	3	上限温度 (Up- category temp.) (C0G/X7R/X7T/X7S: +125 X5R:+85 X6S/X6T:+105)	30min	4	常温 (Normal temp.) : +20°C	2~3min
阶段 Step	温度 (Temperature) (°C)	时间 (Time)																
1	下限温度 (Low- category temp.): :-55	30min																
2	常温 (Normal temp.) : +20°C	2~3min																
3	上限温度 (Up- category temp.) (C0G/X7R/X7T/X7S: +125 X5R:+85 X6S/X6T:+105)	30min																
4	常温 (Normal temp.) : +20°C	2~3min																
试验后放置 (恢复) 时间: 24±2h Recovery time after test: 24±2h																		

项目 Item	技术规格 Technical Specification		测试方法 Test Method and Remarks	
耐湿负荷 Humidity load	ΔC/C	I 类: ±7.5%或±0.75pF,取两者之中较大者 II 类: : ≤±12.5% Class I : ±7.5% or ±0.75pF, whichever is larger. Class II : ≤±12.5%	※预处理 (仅针对 II 类电容器): 在 140°C~150°C 下预热 1h±10min 后, 在室温下 放置 24±2h 温度: 40±2°C 湿度: 90~95%RH 电压: 额定电压 时间: 500 小时 放置条件: 室温 放置时间: 24±2h 小时; II 类: 0201 ≥47nF、0402 ≥33nF、0603 ≥1 μF、 0805 ≥4.7 μF、1206 ≥10 μF 产品试验后需在 150°C 温度下保持 1h, 再放置 24±2h 后测试电 性能。 ※ Pretreatment (Class II) : After preheating at 140°C~150°C for 1h±10min, place at room temperature for 24±2h. Humidity: 90~95%RH Voltage: Rated Voltage Duration: 500h Recovery Time: 24h±2h Class 2: 0201 ≥47nF、0402 ≥33nF、0603 ≥1 μF、 0805 ≥4.7 μF、1206 ≥10 μF product need to keep in 150 °C、1h after the test, and measurement to be made after being kept at room temperature for 24±2h.	
	DF	≤2 倍初始标准 Not more than twice of initial value.		
	IR	Class I		Ri≥5000MΩ或 Ri•Cr≥50S 取两者之中较 小者。 Ri≥5000MΩ或 Ri•Cr≥50S whichever is smaller.
		Class II		Ri≥1000MΩ或 Ri•Cr≥10S 取两者之中较 小者。 Ri≥1000MΩ或 Ri•Cr≥10S whichever is smaller.
外观: 无损伤 Appearance: No visible damage.				

寿命试验 Life Test	ΔC /C	I类	≤±3%或±0.3pF, 取两者之中较大者 ≤±3%或±0.3pF, whichever is larger.
		II类	-20% ~ +20%
	DF	≤2 倍初始标准 Not more than twice of initial value.	
	IR	I类	Ri ≥ 4000MΩ 或 Ri·Cr ≥ 40S 取两者之中较小者 Ri ≥ 4000MΩ 或 Ri·Cr ≥ 40S whichever is smaller.
		II类	Ri ≥ 2000MΩ 或 Ri·Cr ≥ 50S 取两者之中较小者 Ri ≥ 2000MΩ 或 Ri·Cr ≥ 50S whichever is smaller.
外观: 无损伤 Appearance: No visible damage.			

※预处理 (仅针对 II 类电容器):
 在 140°C~150°C 下预热 1h±10min 后, 在室温下放置 24±2h
 低压产品 (<100V) 时间: 1000 小时
 电压: 2 倍额定工作电压, 除了表 1 外
 温度: 125°C (C0G, X7R, X7S) 85°C (X5R) 105°C (X6S, X6T)
 充电电流: 不应超过 50mA.
 放置时间: 24±2h 小时;
 II 类: 0201 ≥ 47nF, 0402 ≥ 33nF, 0603 ≥ 1 μF, 0805 ≥ 4.7 μF, 1206 ≥ 10 μF 产品试验后需在 150°C 温度下保持 1h, 再放置 24±2h 后测试电性能.
 ※ Pretreatment (Class II): After preheating at 140°C~150°C for 1h±10min, place at room temperature for 24±2h.
 Low-Voltage (<100V)
 Applied Voltage: 2*Ur, except the table 1
 Duration: 1000h
 Temperature: 125°C (C0G, X7R, X7S) 85°C (X5R) 105°C (X6S, X6T)
 Charge/ Discharge Current: 50mA max.
 Recovery Time: 24h±2h
 Class 2: 0201 ≥ 47nF, 0402 ≥ 33nF, 0603 ≥ 1 μF, 0805 ≥ 4.7 μF, 1206 ≥ 10 μF product need to keep in 150°C, 1h after the test, and measurement to be made after being kept at room temperature for 24±2h.

容量	试验电压	容量	试验电压
0201 ≥ 10nF	1.5Ur	0805 ≥ 0.47μF	1.5Ur
0402 ≥ 47nF		1206 ≥ 1μF	
0603 ≥ 220nF		1210 ≥ 1μF	

注解:

专门预处理* (仅对 2 类电容器):

将电容器放在上限类别温度或按详细规范中可能规定的更高温度下经 1h 后, 接着在试验的标准大气条件下恢复 24±1h。

Note:

Pretreatment (only for class2 capacitor)

Pretreatment (only for class2 capacitor) is a method to treat the capacitor before measurement. First, place the capacitor in the up-category temperature or other specified higher temperature environment for 1hour. Then recovery the capacitor at standard pressure conditions for 24±1hours.

◆包装

Package

* 塑料压纹带卷盘结构

Embossed Plastic Taping

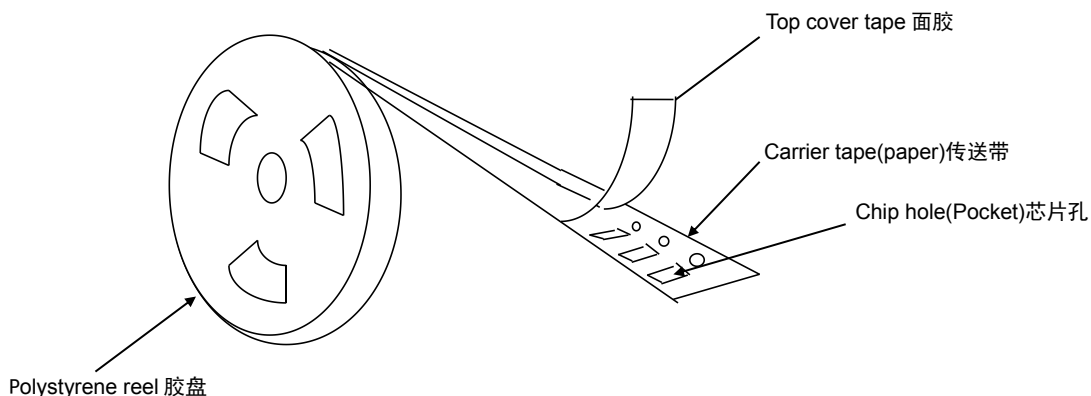

* 仅适用于 1005 规格，压纹带尺寸如下：

The emboss plastic applies only to 1005 type, the dimensions as follows:

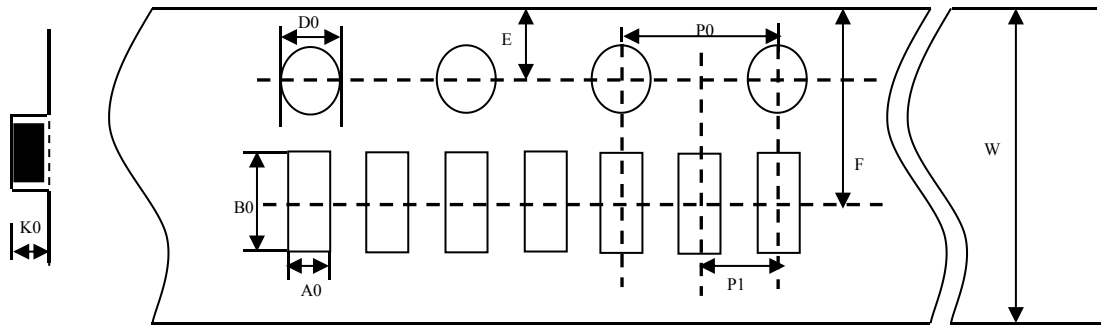

Unit: mm

W	P0	P1	E	F	D0	A0	B0	K0
4±0.05	2±0.04	1±0.02	0.9±0.05	1.8±0.02	0.8±0.04	0.24±0.02	0.45±0.02	0.24±0.02

* 纸带卷盘结构

Paper Taping

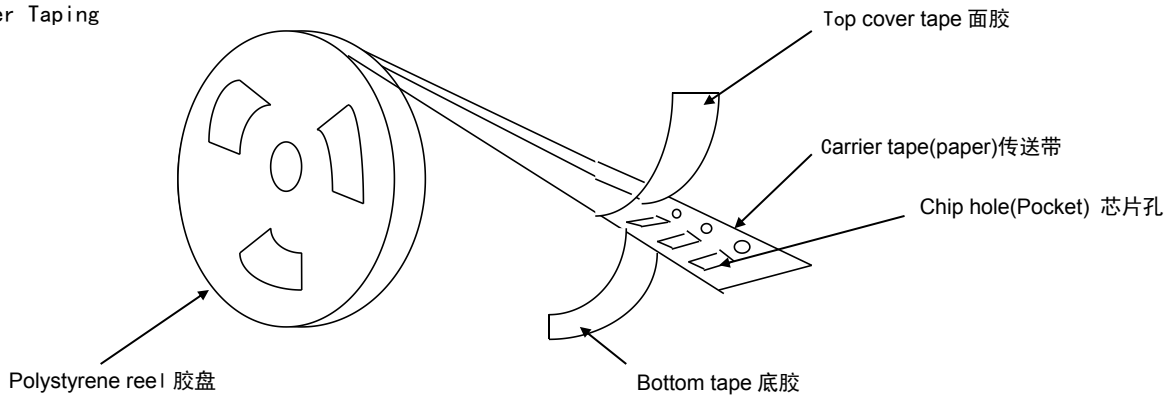

* 1005、0201、0402 纸带编带尺寸大小
Dimensions of paper taping for 1005、0201、0402 type

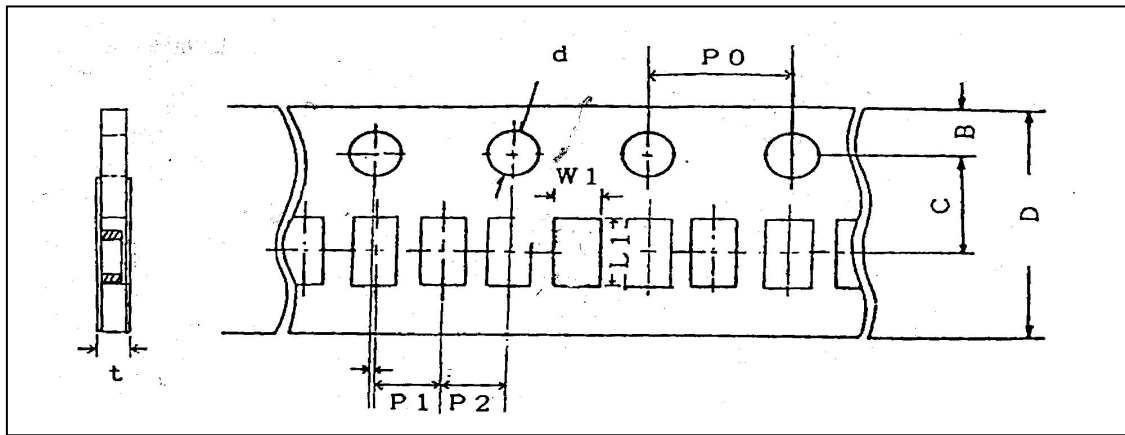

代号 Code	W1	L1	D	C	B	P1	P2	P0	d	t
1005	0.24 ±0.02	0.45 ±0.02	8.00 ±0.10	3.50 ±0.05	1.75 ±0.10	2.00 ±0.05	2.00 ±0.05	4.00 ±0.10	1.50 -0/+0.10	0.30 Below
0201	0.37 ±0.10	0.67 ±0.10	8.00 ±0.10	3.50 ±0.05	1.75 ±0.10	2.00 ±0.05	2.00 ±0.05	4.00 ±0.10	1.50 -0/+0.10	0.80 Below
0402	0.65 ±0.10	1.15 ±0.10	8.00 ±0.10	3.50 ±0.05	1.75 ±0.10	2.00 ±0.05	2.00 ±0.05	4.00 ±0.10	1.50 -0/+0.10	0.80 Below

* 适合 '0603, 0805, 1206' 常规尺寸产品的纸带尺寸
Dimensions of paper taping for 0603, 0805, 1206 types.

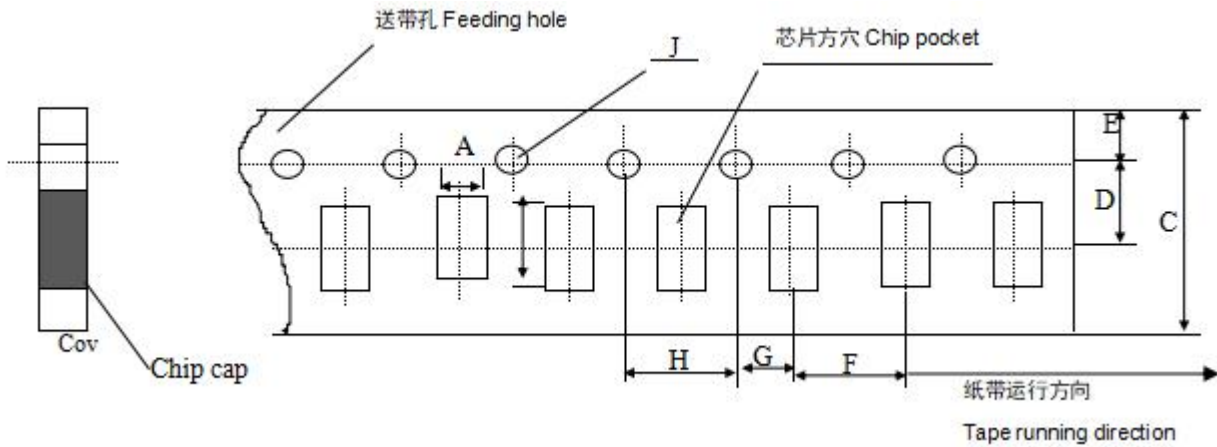

Unit: mm

代号Code 纸带规格 paper size	A	B	C	D*	E	F	G*	H	J	T
0603	1.10 ±0.10	1.90 ±0.10	800 ±0.10	350 ±0.05	1.75 ±0.10	400 ±0.10	200 ±0.10	400 ±0.10	1.50 -0/+0.10	1.10 Max
0805	1.45 ±0.15	2.30 ±0.15	80 ±0.15	350 ±0.05	1.75 ±0.10	400 ±0.10	200 ±0.10	400 ±0.10	1.50 -0/+0.10	1.10 Max
1206	1.80 ±0.20	3.40 ±0.20	800 ±0.20	350 ±0.05	1.75 ±0.10	400 ±0.10	200 ±0.10	400 ±0.10	1.50 -0/+0.10	1.10 Max

注意: *表示此处对尺寸的要求非常精确。
Note: The place with "*" means where needs exactly dimensions.

* 塑胶卷盘结构

Embossed taping

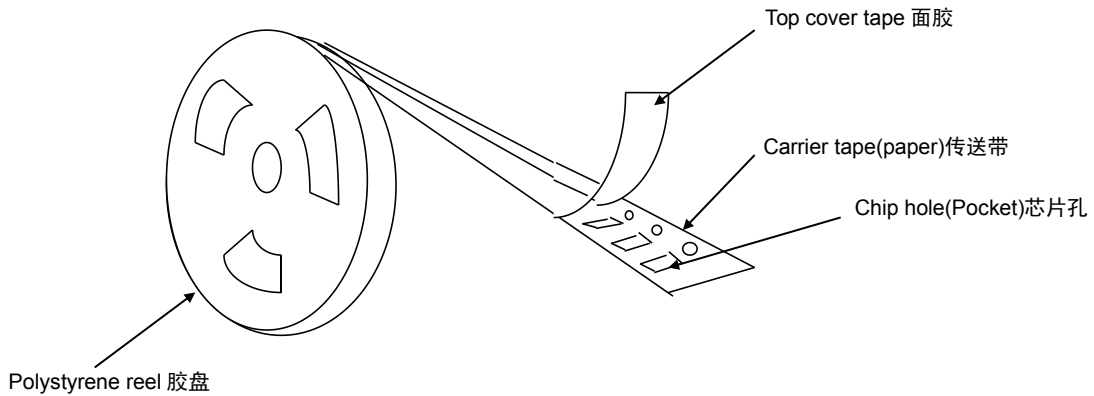

* 塑胶带尺寸结构 (适合'0805~1812' 型产品)

Dimensions of embossed taping for 0805~1812 type

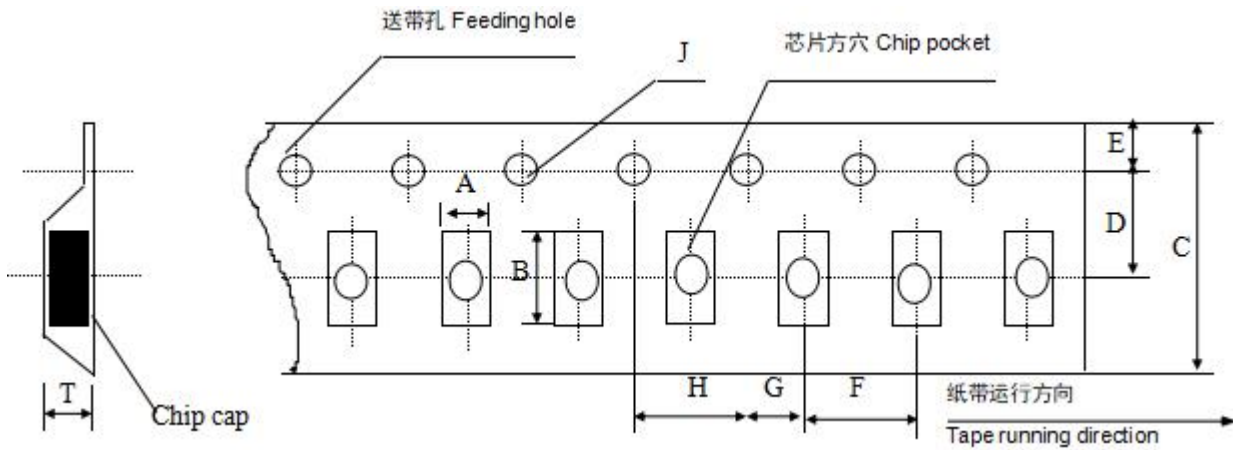

代号 Code 规格 Tape size	A	B	C	D*	E	F	G*	H	J	T
0805	1.55 ± 0.20	2.35 ± 0.20	8.00 ± 0.20	3.50 ± 0.05	1.75 ± 0.10	4.00 ± 0.10	2.00 ± 0.10	4.00 ± 0.10	1.50 -0/+0.10	1.50 Max
1206	1.95 ± 0.20	3.60 ± 0.20	8.00 ± 0.20	3.50 ± 0.05	1.75 ± 0.10	4.00 ± 0.10	2.00 ± 0.10	4.00 ± 0.1	1.50 -0/+0.10	1.85 Max
1210	2.70 ± 0.10	3.42 ± 0.10	8.00 ± 0.10	3.50 ± 0.05	1.75 ± 0.10	4.00 ± 0.10	2.00 ± 0.05	4.00 ± 0.10	1.55 -0/+0.10	3.2 Max
1808	2.20 ± 0.10	4.95 ± 0.10	12.00 ± 0.10	5.50 ± 0.05	1.75 ± 0.10	4.00 ± 0.10	2.00 ± 0.05	4.00 ± 0.10	1.50 -0/+0.10	3.0 Max
1812	3.66 ± 0.10	4.95 ± 0.10	12.00 ± 0.10	5.50 ± 0.05	1.75 ± 0.10	8.00 ± 0.10	2.00 ± 0.05	4.00 ± 0.10	1.55 -0/+0.10	4.0 Max

备注: *表示此处对尺寸的要求非常精确。

Note: The place with "*" means where needs exactly dimensions.

* 传送带的前后结构

Structure of leader part and end part of the carrier paper

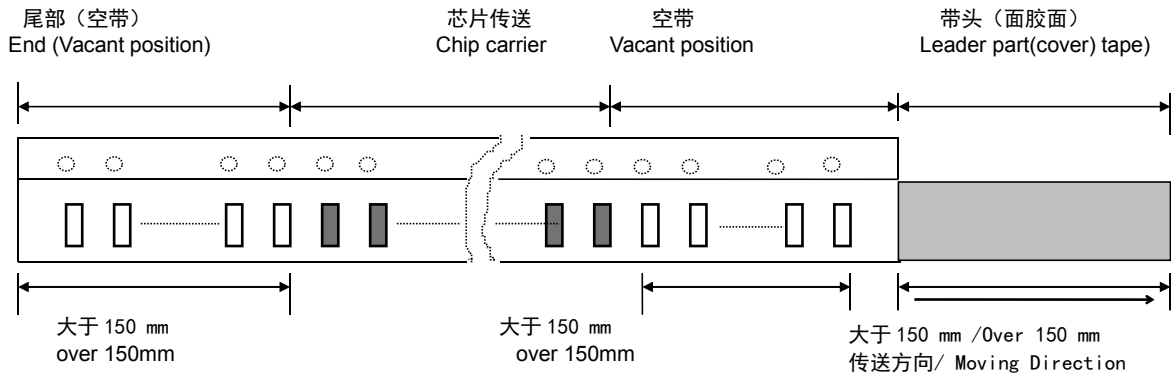

* 卷盘尺寸

Reel dimensions (unit: mm)

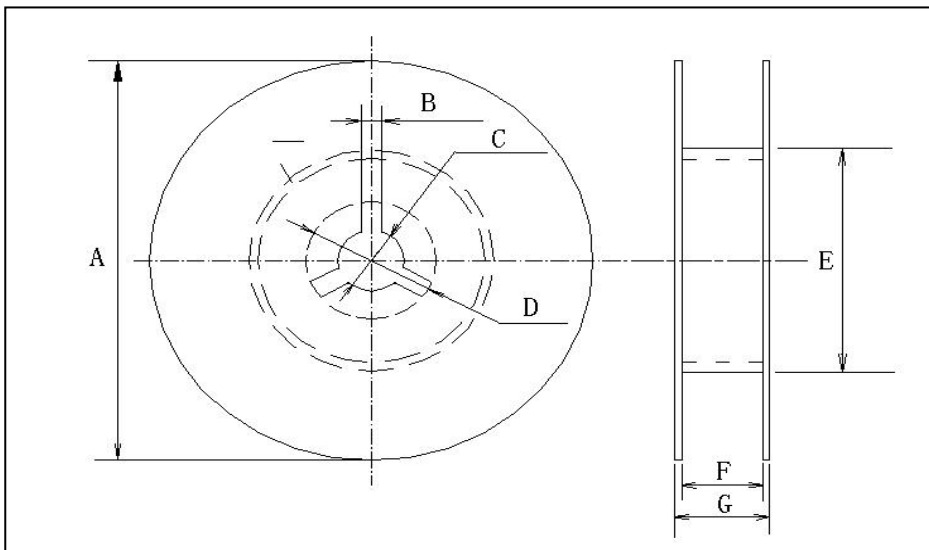

卷盘型号	A	B	C	D	E	F	G
7'REEL	$\phi 178 \pm 2.0$	3.0	$\phi 13 \pm 0.5$	$\phi 21 \pm 0.8$	$\phi 50$ 或更大 $\phi 50$ or more	10.0 ± 1.5	12max

* 关于卷带的说明：面胶剥离强度

Taping specification: top tape peeling strength

纸带 Paper Taping

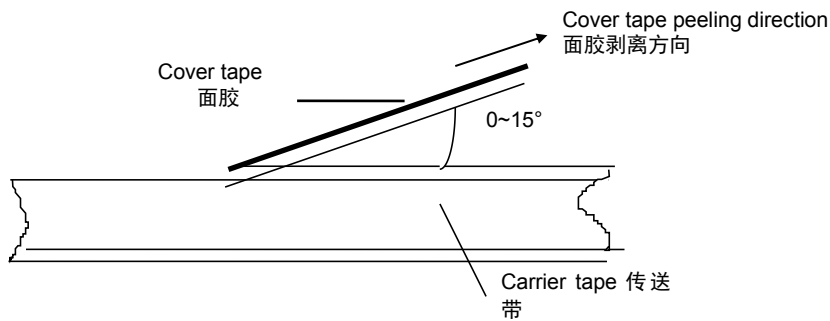

* 塑料胶盘 Embossed Taping

Cover tape peeling direction 面胶剥离方向

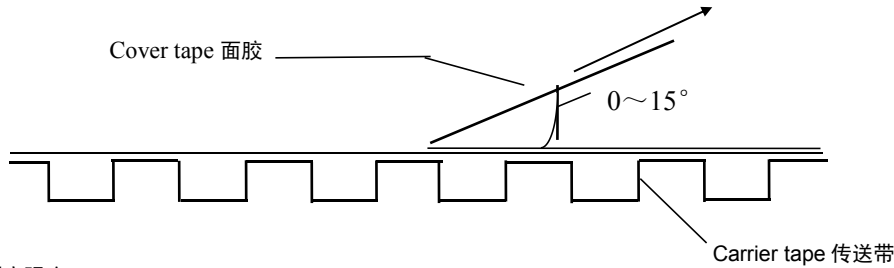

标准: 0.1N<剥离强度<0.7N

Standard: 0.1N < peeling strength < 0.7N

在剥离时, 纸带不能有纸碎, 也不能粘在底、面胶上。

No paper dirty remains on the scotch when peeling, and sticks to top and bottom tape.

* 塑料盒散包装

Bulk Case Package

单位 (unit) :mm

Symbol	A	B	T	C	D	E
Dimension	6.80±0.10	8.80±1.00	12.00±0.10	15.00+0.10/-0	2.00+0/-0.10	4.70±0.10
Symbol	F	W	G	H	L	I
Dimension	31.50+0.20/-0	36.00+0/-0.20	19.00±0.35	7.00±0.35	110.00±0.70	5.00±0.35

* 包装数量

Packing Quantity

尺寸 (SIZE)	包装形式和数量 (Package Style & Quantity) unit: pcs				
	塑料压纹带卷盘 (EPT)	纸带卷盘 (PT)	胶带卷盘 (ET)	塑料盒散装 (BC)	一般散装 (BP)
1005	---	20000	---	---	---
0201	---	15000	---	---	---
0402	-----	10000	-----	20000	5000
0603	-----	4000	-----	15000	5000
0805	-----	4000	3000	10000	5000
1206	-----	4000	T≤1.35mm 3000 T>1.35mm 2000	5000	5000
1210	-----	-----	T≤1.80mm 2000 T>1.80mm 1000	-----	2000
1808	-----	-----	2000	-----	2000
1812	-----	-----	T≤1.85mm 1000 T>1.85mm 500	-----	2000

注意: 包装的形式和数量可根据客户的要求来定。

Note: We can choose packing style and quantity can be according to the customer's requirement.

*** 外包装**
Outer packing

小包装 The first package

Quantity: 10 reels

数量: 10 卷

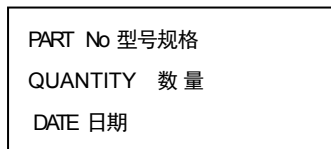
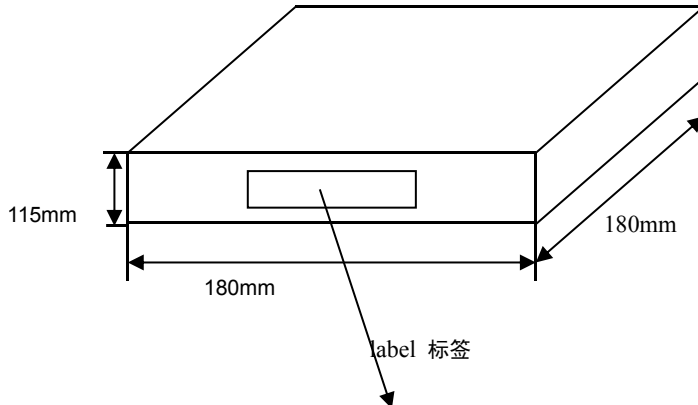

大包装 The second package

Quantity: 6 cases

数量: 6 盒

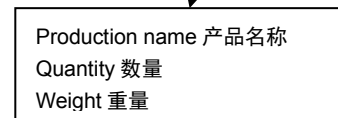
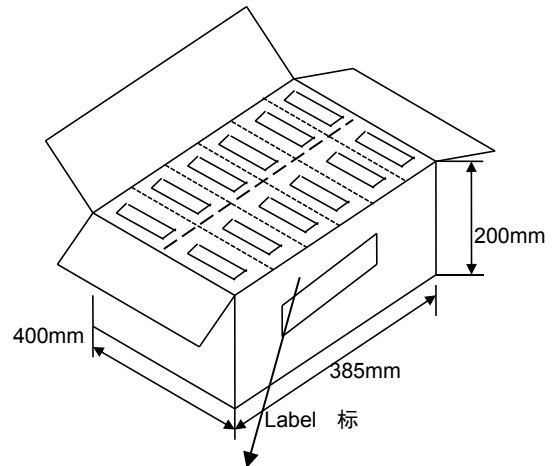
◆ 储存方法
Storage Methods

* 确保芯片可焊性良好的贮存期限为 12 个月(在包装好已交付的情况下)。

The guaranteed period for solderability is 12 months (Under deliver package condition).

* 储存条件 Storage conditions:

储存温度/Temperature 5~40℃

储存相对湿度/Relative Humidity 20~70%

◆ 使用前的注意事项
Precautions For Use

多层片式瓷介电容器(MLCC)在短路或开路的电路中都有可能失效,在超出本承认书或相关说明书中所述使用频率的恶劣工作环境,或外界机械力超压作用下,电容芯片都有可能着火、燃烧甚至爆炸,所以在使用的時候,首先应考虑按本承认书的有关说明来进行,如有不明之处,请联系我们技术部、品管部或生产部。

The Multi-layer Ceramic Capacitors (MLCC) may fail in a short circuit modern in an open circuit mode when subjected to severe conditions of electrical environment and / or mechanical stress beyond the specified "rating" and specified "conditions" in the specification, which will result in burn out, flaming or glowing in the worst case. Following "precautions for "safety" and Application Notes shall be taken in your major consideration. If you have a question about the precautions for handling, please contact our engineering section or factory.

* 焊接的条件与相关图表

Soldering Profile

为避免因温度的突然变化而引起的芯片开裂或局部爆炸的现象发生,请按有关温度曲线图表来进行。(请参考附页中的图表)

To avoid the crack problem by sudden temperature change, follow the temperature profile in the adjacent graph (refer to the graph in the enclosure page).

* 手工焊接

Manual Soldering

手工焊接很容易因为芯片局部受热不均而引起瓷体微裂或局部爆炸的现象,在焊接时,如果操作者不小心,会使烙铁头直接同电容芯片的瓷体部分接触,这样很容易使电容芯片因热冲击而受损或出现其他意外.因此,使用电烙铁手工焊接时应仔细操作,并对电烙铁的尖端的选择和尖端温度控制应多加小心。

Manual soldering can pose a great risk of creating thermal cracks in capacitors. The hot soldering iron tip comes into direct contact with the end terminations, and operator's careless may cause the tip of the soldering iron to come into direct contact with the ceramic body of the capacitor. Therefore the soldering iron must be handled carefully, and pay much attention to the selection of the soldering iron tip and temperature contact of the tip.

***适量的焊料**

Optimum Solder Amount for Reflow Soldering

焊料过多
Too much solder

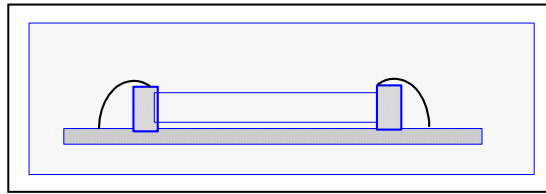

这样会因端头压力过大而
可能引起芯片受损
Cracks tend to occur due to large stress.

焊料太少
Not enough solder

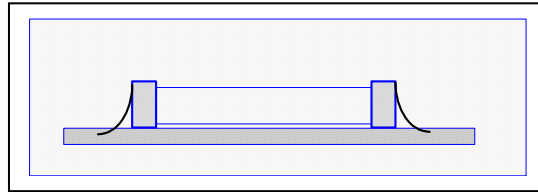

固定力量不足,可能会引起
电容芯片与线路接触不良
Weak holding force may cause
badconnection
between the capacitor and PCB.

*** 推荐焊料用量**

Recommended Soldering amounts

回流焊接的最佳焊料用量

The optimal solder fillet amounts for re-flow soldering

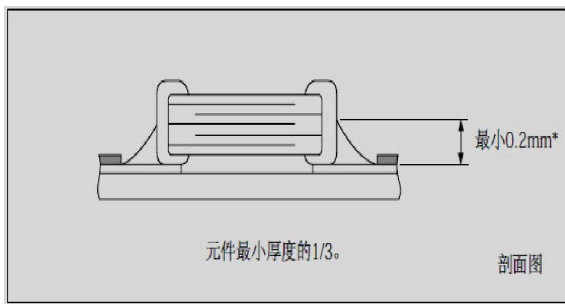

波峰焊接的最佳焊料用量

The optimal solder fillet amounts for wave soldering

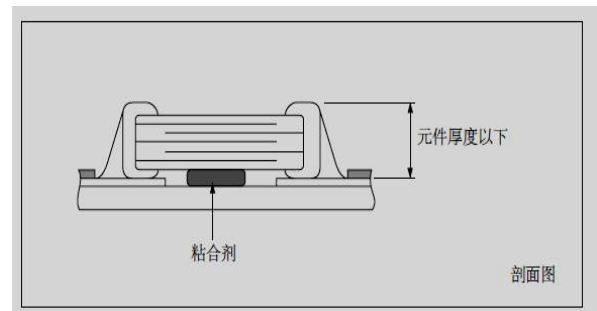

使用烙铁返修时的最佳焊料量

The optimal solder fillet amounts for reworking by using soldering iron

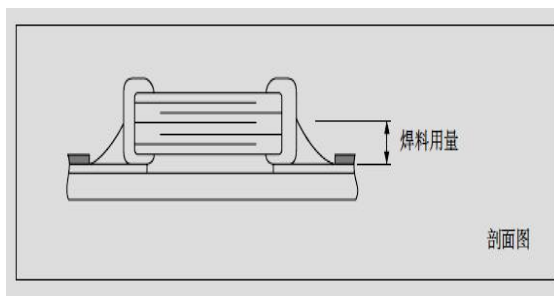

*** 推荐焊接方式**

Recommended Soldering Method

规格尺寸 Size	温度特性 Temperature Characteristics	额定电压 Rated Voltage	容量范围 Capacitance	焊接方式 Soldering Method
1005	C0G	/	/	R
	X7R/X5R/X7T/X6S	/	/	R
0201	C0G	/	/	R
	X7R/X5R/X7T/X6S	/	/	R

***推荐焊接方式**
Recommended Soldering Method

规格尺寸 Size	温度特性 Temperature Characteristics	额定电压 Rated Voltage	容量范围 Capacitance	焊接方式 Soldering Method
0402	C0G	/	/	R
	X7R/X5R/X7T/X6S	/	/	R
0603	C0G	/	/	R/W
	X7R/X5R/X7T/X6S	/	$C \geq 1\mu\text{f}$	R
			$C < 1\mu\text{f}$	R/W
0805	C0G	/	/	R/W
	X7R/X5R/X7T/X6S	/	$C \geq 4.7\mu\text{f}$	R
			$C < 4.7\mu\text{f}$	R/W
1206	C0G	/	/	R/W
	X7R/X5R/X7T/X6S	/	$C \geq 10\mu\text{f}$	R
			$C < 10\mu\text{f}$	R/W
≥ 1210	C0G	/	/	R
	X7R/X5R/X7T/X6S	/	/	R

焊接方式 Soldering method:

R—回流焊 Reflow Soldering

W—波峰焊 Wave Soldering

◆ 推荐焊接温度曲线图
The temperature profile for soldering

* 回流焊接 (Re-flow soldering)

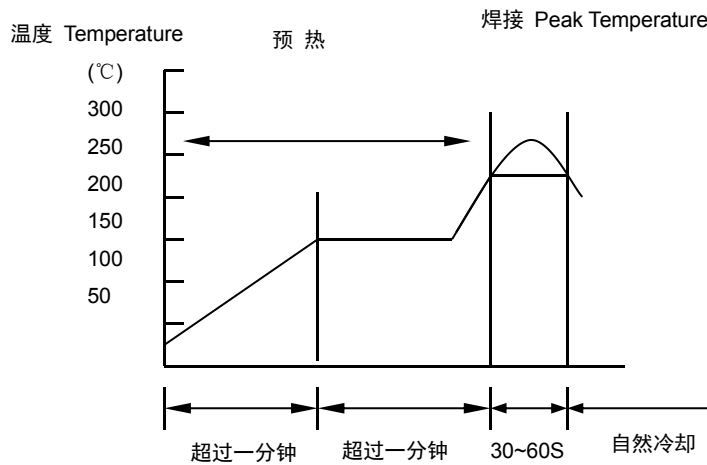

	Pb-Sn 焊接 Pb-Sn soldering	无铅焊接 Lead-free soldering
尖峰温度 Peak temperature	230°C~250°C	240°C~260°C

 在预热时, 请将焊接温度与芯片表面温度之间的温差维持在 $T \leq 150^\circ\text{C}$ 。

 While in preheating, please keep the temperature difference between soldering temperature and surface temperature of chips as: $T \leq 150^\circ\text{C}$.

* 波峰焊接
(Wave soldering)

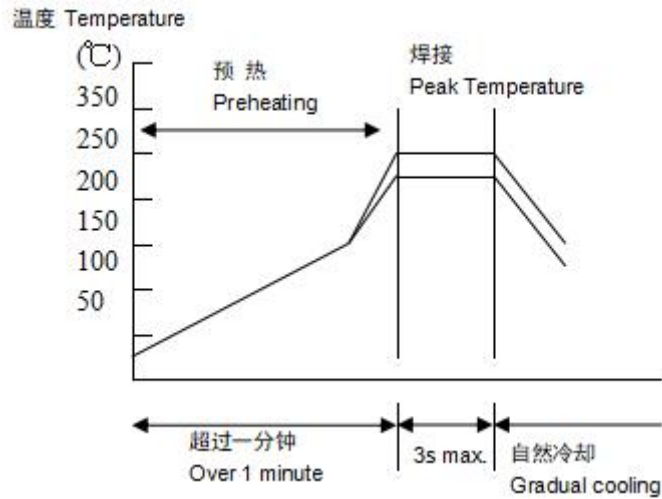

	Pb-Sn 焊接 Pb-Sn soldering	无铅焊接 Lead-free soldering
尖峰温度 Peak temperature	230°C~260°C	240°C~270°C

在预热时, 请将焊接温度与芯片表面温度之间的温差维持在 $T \leq 150^\circ\text{C}$ 。

While in preheating, please keep the temperature difference between soldering temperature and surface temperature of chips as: $T \leq 150^\circ\text{C}$.

* 手工焊接
Hand soldering

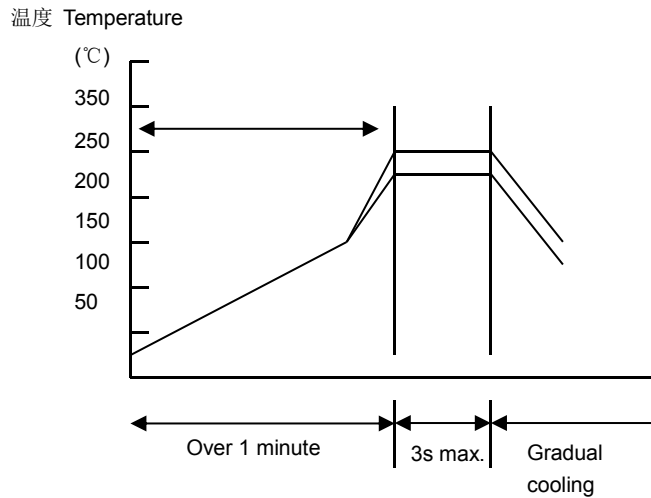

条件 Conditions:

预热 Preheating	烙铁头温度 Temperature of soldering iron head	烙铁功率 Power of soldering iron	烙铁头直径 Diameter of soldering iron head	焊接时间 Soldering time	锡膏量 Solder paste amount	限制条件 Restricted conditions
$\Delta \leq 130^\circ\text{C}$	最高 350°C Highest temperature: 350°C	最大 20W 20W at the highest	建议 1mm 1mm recommended	最长 3s 3s at the longest	$\leq 1/2$ 芯片厚度 $\leq 1/2$ chip thickness	请勿使用烙铁头直接接触陶瓷元件 Please avoid the direct contact between soldering iron head and ceramic components

*上述内容仅提供客户选型参考, 不作任何承诺。我司保有修改此内容不另行通知之所有权利。

The above content is only for customer selection reference and does not make any promises.

Our company reserves the right to modify this content without prior notice

