



**SILERGY**

# SY67134 Medium Voltage H-Bridge IC

## General Description

The SY67134 is a H-bridge motor driver solution for motion-control applications. The highly integrated H-bridge driver block consists of two half-bridges with internal logic control, gate drive, over current protection and charge pump circuit.

The SY67134 operates with a power-supply voltage range from 5V to 40V, and 3.6A maximum output current. To be compatible with industry-standard devices, the SY67134 uses the PWM input interface. The SY67134 also provides over current protection, under voltage lockout and thermal shutdown protection. The device is packaged in SO8E.

## Ordering Information

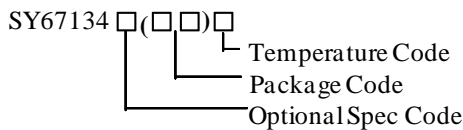

Ordering Number	Package type	Note
SY67134FCC	SO8E	

## Features

- Power Supply Voltage Range from 5V to 40V
- 3.6A Maximum Drive Current
- H-bridge Motor Driver
- PWM Interface
- Low Power Standby Mode with Less than 15µA Supply Current
- Internal Over Current Protection, Under Voltage Lockout and Thermal Shutdown
- Automatic Fault Recovery
- Synchronous Rectification
- Compact Package: SO8E

## Applications

- Consumer Products
- Robotics

## Typical Application

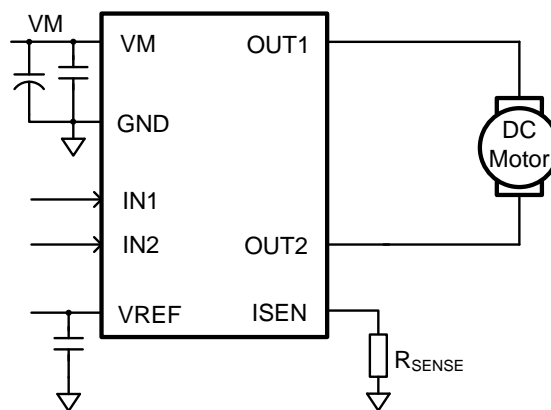
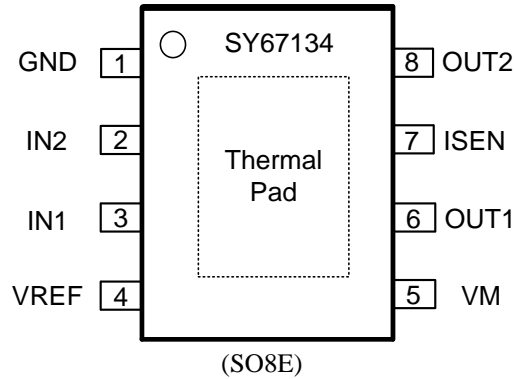

Figure1. Typical Application Circuit

## Pin out (Top View)



**Top Mark:** CFXxyz (device code: CFX, x=year code, y=week code, z=lot number code)

Name	Number	Description
GND	1	Ground pin.
IN2	2	Logic input 2 pin. Logic high set OUT2 High, this pin has an internal pull-down resistor.
IN1	3	Logic input 1 pin. Logic high set OUT1 High, this pin has an internal pull-down resistor.
VREF	4	Current regulator voltage reference. $I_{CHOP} = VREF/10/R_{SENSE}$ . Decouple this pin to GND with at least 0.1uF ceramic capacitor.
VM	5	Power supply pin. Decouple this pin to GND with 10uF ceramic cap and sufficient electronic capacitor.
OUT1	6	Output 1 pin. Connect this pin to motor winding.
ISEN	7	Current sense resistor connection pin.
OUT2	8	Output 2 pin. Connect this pin to motor winding.
Thermal Pad	-	Exposed pad for enhanced thermal dissipation. Connect to ground for maximum thermal efficiency.

## Block Diagram

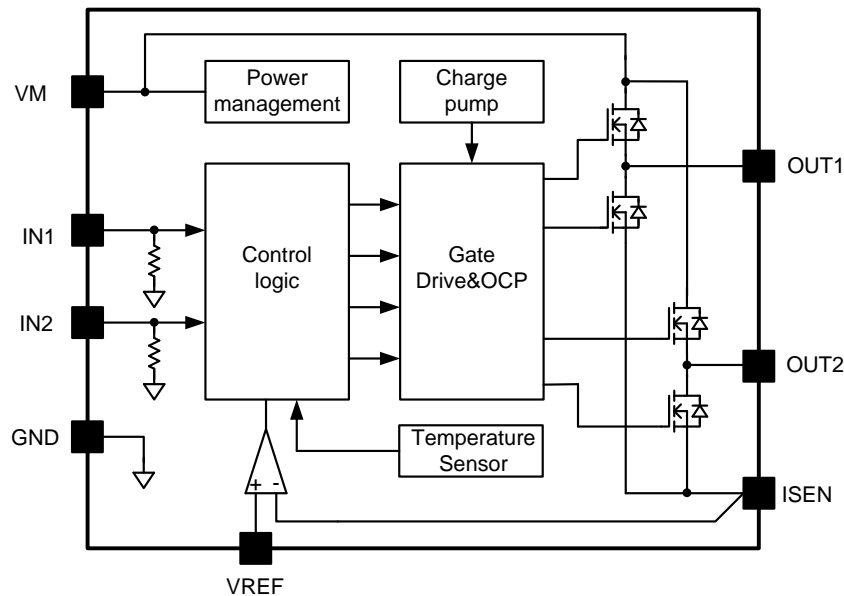

**Figure2. Block Diagram**



---

**Absolute Maximum Ratings** (Note 1)

VM, OUT1, OUT2	-----	-0.3V to 40V
IN1, IN2	-----	-0.3V to 6V
VREF	-----	-0.3V to 4V
ISEN	-----	-0.3V to 4V
Junction Temperature (T <sub>J</sub> )	-----	-40°C to +150°C
Storage Temperature	-----	-55°C to +150°C
Package Thermal Resistance		
θ <sub>JA</sub> (Note 2)	-----	62°C/W
θ <sub>JC</sub> (Note 2)	-----	20°C/W

**Recommended Operating Conditions**

VM, OUT1, OUT2	-----	5V to 32V
IN1, IN2	-----	0V to 5V
VREF	-----	0V to 3.3V
ISEN	-----	-0.3V to 0.3V
R <sub>SENSE</sub>	-----	less than 100mΩ
Logic Input PWM Frequency	-----	0Hz to 100 kHz
H-Bridge Output Current (Note3)	-----	0 to 3.6A
Junction Temperature Range	-----	-40°C to 125°C
Ambient Temperature Range	-----	-40°C to 85°C

## Electrical Characteristics

( $T_A = 25^\circ\text{C}$ ,  $V_M=24\text{V}$ , unless otherwise specified)

Parameter	Symbol	Test Conditions	Min.	Typ.	Max.	Unit
<b>Power Supply</b>						
Supply Voltage Range	$V_M$		5		32	V
Under Voltage Threshold	$V_{UVLO\_TH}$	$V_M$ Rising		4.7	5	V
Under Voltage Hysteresis	$V_{UVLO\_HYS}$			200		mV
VM Operating Supply Current	$I_{IN}$	Low power standby mode			15	$\mu\text{A}$
		<30kHz PWM, OUTx float			3	mA
<b>Logic Level Input</b>						
Input Low Voltage	$V_{IL}$				0.5	V
Input High Voltage	$V_{IH}$		1.5			V
Input Low Current	$I_{IL}$	$V_{INX}=0\text{V}$	-1	0	1	$\mu\text{A}$
Input High Current	$I_{IH}$	$V_{INX}=3.3\text{V}$	20	50	100	$\mu\text{A}$
<b>H-Bridge MOSFETs</b>						
HS + LS MOSFETs on Resistance	$R_{dson}$				500	m $\Omega$
Off-State Leakage Current	$I_{OFF}$				$\pm 500$	nA
Dead time	$T_D$	(Note 4)			500	ns
<b>Current Regulation</b>						
Current Regulation Reference Voltage	$V_{REF}$	Use external voltage as VREF	0.1		3	V
Current Gain	$A_V$	$V_{REF}/I_{CHOP}$ , $V_{REF}=2\text{V}$	9.5		10.5	V/V
Blank Time	$T_{BLANK}$		1	2	3	$\mu\text{s}$
Constant Off-time	$T_{OFF}$		12	24	35	$\mu\text{s}$
<b>Timing</b>						
Time to Standby Mode	$T_{ESTB}$	$IN1=IN2 < V_{IL}$ , (Note 4)		1		ms
<b>Protection</b>						
Output Over Current Limit	$I_{OCP}$		3.65	4.5	5.5	A
OCP Regulate Time	$t_{REG}$	(Note 4)		1.5		$\mu\text{s}$
OCP Retry Time	$t_{RTY}$	(Note 4)		3		ms
Thermal Shutdown Temperature	$T_{SD}$	(Note 4)		165		$^\circ\text{C}$
Thermal Shutdown Hysteresis	$T_{HYS}$	(Note 4)		30		$^\circ\text{C}$

**Note 1:** Stresses listed as the above “Absolute Maximum Ratings” may cause permanent damage to the device. These are for stress ratings. Functional operation of the device at these or any other conditions beyond those indicated in the operational sections of the specifications is not implied. Exposure to absolute maximum rating conditions for extended periods may remain possibility to affect device reliability.

**Note 2:**  $\theta_{JA}$  is measured in the natural convection at  $T_A = 25^\circ\text{C}$  on a two-layer SILERGY Evaluation Board.

**Note 3:** Power dissipation and thermal limits must be observed.

**Note 4:** This spec does not test, and it is guaranteed by design.

# Typical Performance Characteristics

Operation Waveform  
(VM=12V, Io=1A, IN1=PWM)

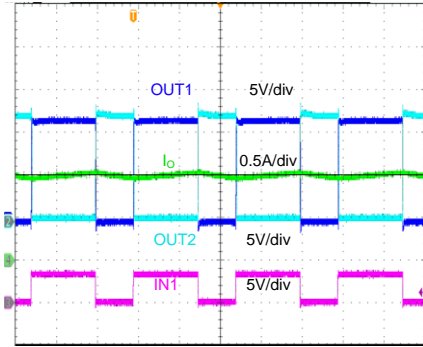

Time (20µs/div)

Operation Waveform  
(VM=12V, Io=1A, IN2=PWM)

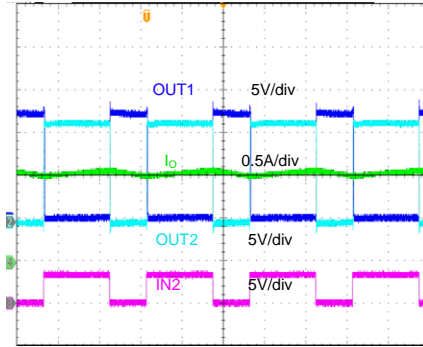

Time (20µs/div)

Operation Waveform  
(VM=12V, Io=1A, IN2=PWM, IN1=High)

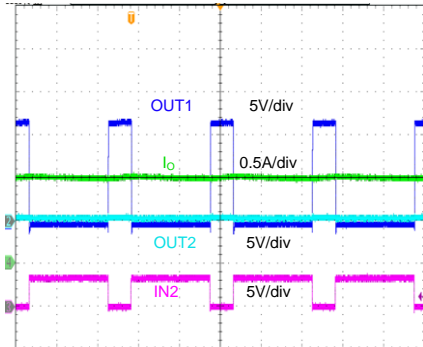

Time (20µs/div)

Operation Waveform  
(VM=12V, Io=1A, IN1=PWM, IN2=High)

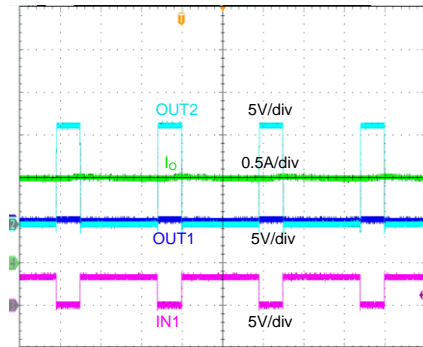

Time (20µs/div)

Operation Waveform  
(VM=12V, Io=1A, IN1=IN2)

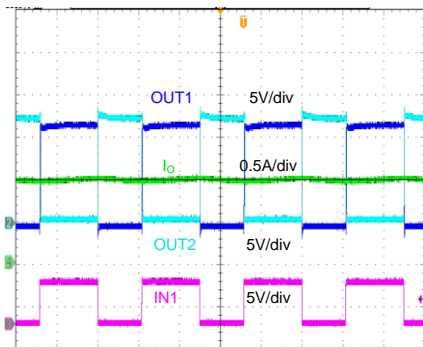

Time (20µs/div)

Operation Waveform  
(VM=12V, Io=1A, IN2=IN1)

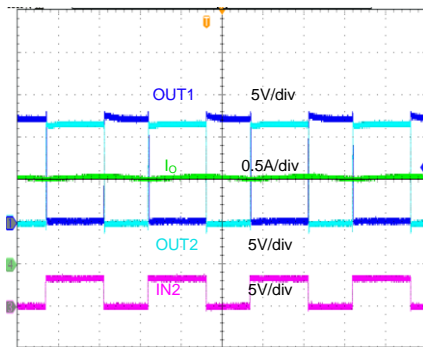

Time (20µs/div)

## Functional Description

### H-Bridge Control

The bridge is controlled by a PWM input interface, and the following table shows the control logic of the device:

Table 1. Truth Table

IN1	IN2	OUT1	OUT2	Function (DC Motor)
0	0	Z	Z	Coast
0	1	L	H	Reverse
1	0	H	L	Forward
1	1	L	L	Brake

### Standby Mode

Low power standby mode will be active when both input IN1 and IN2 pin voltage are logic low for longer than 1ms. Standby Mode disables most of the internal circuitry, including the charge pump and the regulator. Any PWM commands are issued to the device, before the IC comes out of standby mode, the charge pump should be allowed to reach its regulated voltage (a maximum delay of 200us).

### Current Regulation

When voltage of the current sense resistor is equals to the comparator trip value, the IC will enter into mix decay mode. The IC decays the current at fixed off time of 24us. The PWM chopping current is set by a comparator which compares the voltage across a current sense resistor connected to the ISEN pin with a reference voltage.

The chopping current is calculated in Equation 1.

$$I_{CHOP} = \frac{VREF}{10 \times R_{SENSE}} \tag{1}$$

Example:

If a 0.05Ω sense resistor is used, and VREF=1V, the chopping current will be 1V/10/0.05 Ω = 2A.

Once the chopping current threshold is reached, the H-bridge will switch to decay mode. At the beginning of decay, the motor runs at fast decay, then the motor runs at slow decay.

Note that if current control is not needed, the ISEN pin should be connected to ground directly.

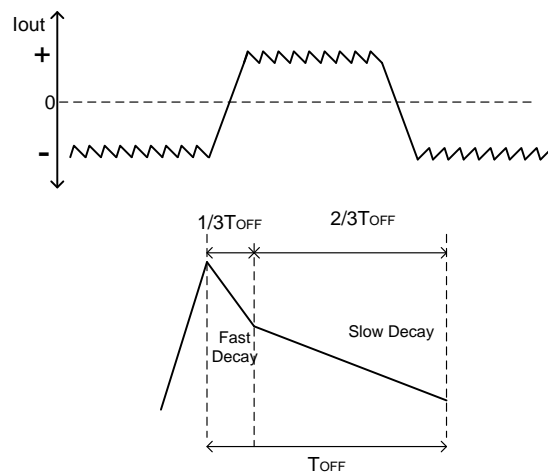

Figure 3. Current Regulation and Decay timing

## Synchronous Rectification

When the current regulation is triggered, load current will recirculate. The IC turn on the MOSFETs, and short the body diode. This helps to lower the power dissipation. When a zero current is detected, the synchronous rectification will be turn off to prevent reversal of the load current.

## Protection Circuits

The device is fully protected against under voltage, over current and thermal shutdown.

### Over Current Protection (OCP)

An analog current limit circuit on each FET limits the current through the FET. If this analog current limit persists for longer than the OCP regulation time, all FETs in the H-bridge will be disabled. The driver will be re-enabled after the OCP retry period ( $t_{RTY}$ ) passed. If the fault condition is still present, the cycle will repeat. If the fault is no longer present, normal operation will resume.

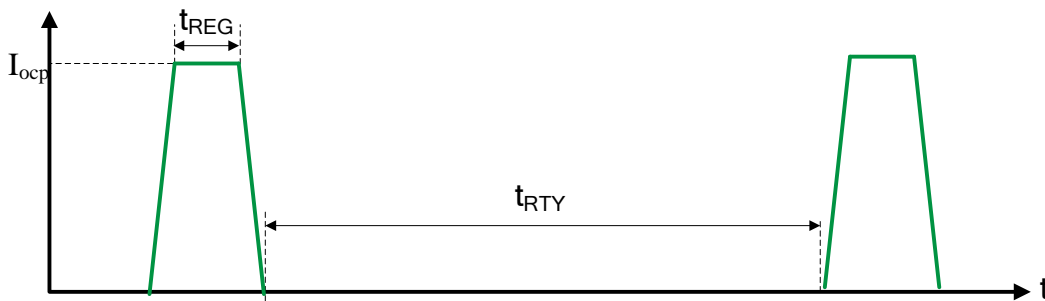

Figure 4. OCP schematic

### Under Voltage Lockout (UVLO)

If at any time the voltage on the VM pin falls below the under voltage lockout threshold voltage, all circuitry in the device will be disabled and internal logic will be reset. Operation will resume when VM rises above the UVLO threshold.

### Thermal Shutdown Protection (TSD)

The device has thermal shutdown as described in the Protection Circuits section. If the die temperature exceeds approximately 165°C, the device will be disabled until the temperature drops to a safe level. Any tendency of the device to enter thermal shutdown is an indication of either excessive power dissipation, insufficient heatsinking, or a too high ambient temperature.

**SO8E Package Outline & PCB layout**

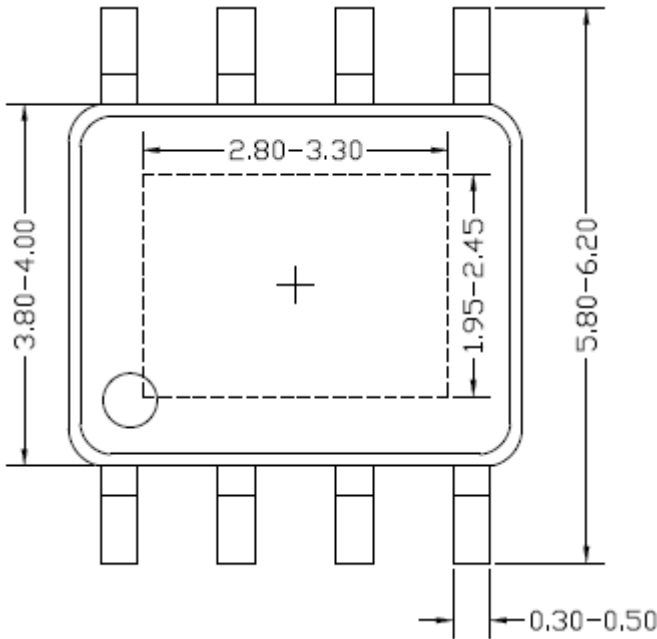

**Top view**

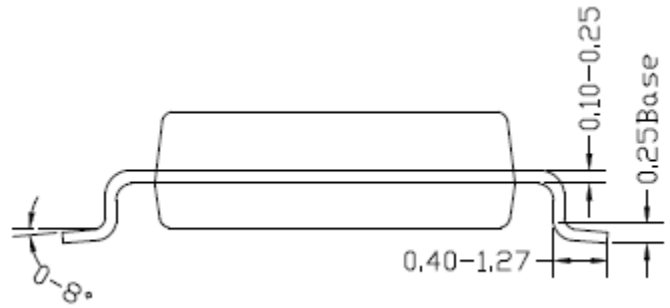

**Side view**

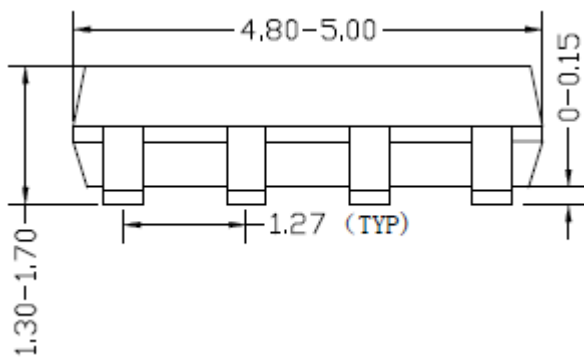

**Front view**

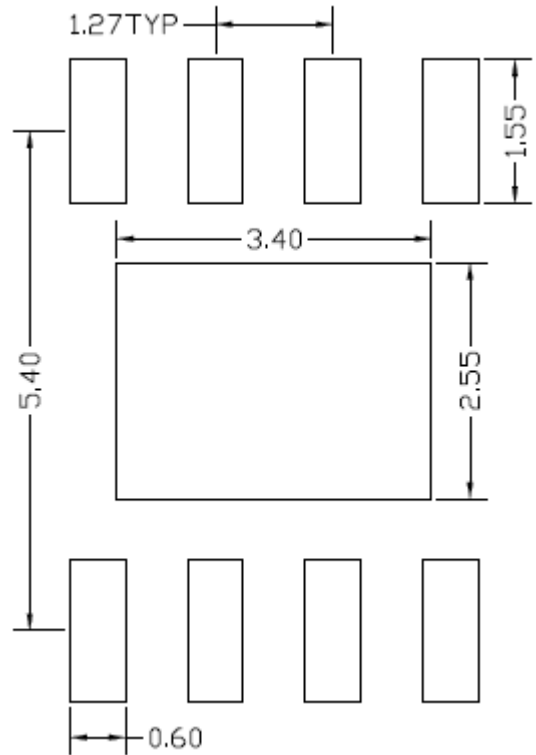

**Recommended PCB Layout  
(Reference Only)**

**Notes: All dimension in millimeter and exclude mold flash & metal burr.**

## Taping & Reel Specification

### 1. Taping orientation

**SO8E**

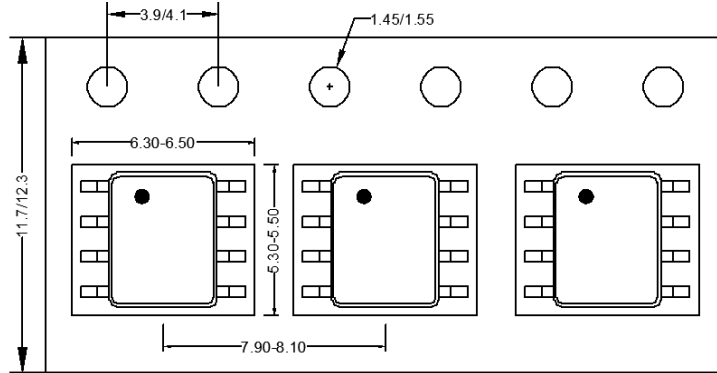

Feeding direction →

### 2. Carrier Tape & Reel specification for packages

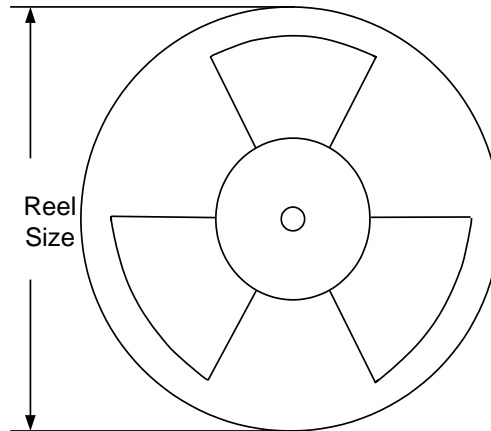

Package types	Tape width (mm)	Pocket pitch(mm)	Reel size (Inch)	Trailer * length(mm)	Leader * length (mm)	Qty per reel (pcs)
SO8E	12	8	13"	400	400	2500

### 3. Others: NA



---

**IMPORTANT NOTICE**

1. **Right to make changes.** Silergy and its subsidiaries (hereafter Silergy) reserve the right to change any information published in this document, including but not limited to circuitry, specification and/or product design, manufacturing or descriptions, at any time and without notice. This document supersedes and replaces all information supplied prior to the publication hereof. Buyers should obtain the latest relevant information before placing orders and should verify that such information is current and complete. All semiconductor products are sold subject to Silergy's standard terms and conditions of sale.
2. **Applications.** Application examples that are described herein for any of these products are for illustrative purposes only. Silergy makes no representation or warranty that such applications will be suitable for the specified use without further testing or modification. Buyers are responsible for the design and operation of their applications and products using Silergy products. Silergy or its subsidiaries assume no liability for any application assistance or designs of customer products. It is customer's sole responsibility to determine whether the Silergy product is suitable and fit for the customer's applications and products planned. To minimize the risks associated with customer's products and applications, customer should provide adequate design and operating safeguards. Customer represents and agrees that it has all the necessary expertise to create and implement safeguards which anticipate dangerous consequences of failures, monitor failures and their consequences, lessen the likelihood of failures that might cause harm and take appropriate remedial actions. Silergy assumes no liability related to any default, damage, costs or problem in the customer's applications or products, or the application or use by customer's third-party buyers. Customer will fully indemnify Silergy, its subsidiaries, and their representatives against any damages arising out of the use of any Silergy components in safety-critical applications. It is also buyers' sole responsibility to warrant and guarantee that any intellectual property rights of a third party are not infringed upon when integrating Silergy products into any application. Silergy assumes no responsibility for any said applications or for any use of any circuitry other than circuitry entirely embodied in a Silergy product.
3. **Limited warranty and liability.** Information furnished by Silergy in this document is believed to be accurate and reliable. However, Silergy makes no representation or warranty, expressed or implied, as to the accuracy or completeness of such information and shall have no liability for the consequences of use of such information. In no event shall Silergy be liable for any indirect, incidental, punitive, special or consequential damages, including but not limited to lost profits, lost savings, business interruption, costs related to the removal or replacement of any products or rework charges, whether or not such damages are based on tort or negligence, warranty, breach of contract or any other legal theory. Notwithstanding any damages that customer might incur for any reason whatsoever, Silergy' aggregate and cumulative liability towards customer for the products described herein shall be limited in accordance with the Standard Terms and Conditions of Sale of Silergy.
4. **Suitability for use.** Customer acknowledges and agrees that it is solely responsible for compliance with all legal, regulatory and safety-related requirements concerning its products, and any use of Silergy components in its applications, notwithstanding any applications-related information or support that may be provided by Silergy. Silergy products are not designed, authorized or warranted to be suitable for use in life support, life-critical or safety-critical systems or equipment, nor in applications where failure or malfunction of an Silergy product can reasonably be expected to result in personal injury, death or severe property or environmental damage. Silergy assumes no liability for inclusion and/or use of Silergy products in such equipment or applications and therefore such inclusion and/or use is at the customer's own risk.
5. **Terms and conditions of commercial sale.** Silergy products are sold subject to the standard terms and conditions of commercial sale, as published at <http://www.silergy.com/stdterms>, unless otherwise agreed in a valid written individual agreement specifically agreed to in writing by an authorized officer of Silergy. In case an individual agreement is concluded only the terms and conditions of the respective agreement shall apply. Silergy hereby expressly objects to and denies the application of any customer's general terms and conditions with regard to the purchase of Silergy products by the customer.
6. **No offer to sell or license.** Nothing in this document may be interpreted or construed as an offer to sell products that is open for acceptance or the grant, conveyance or implication of any license under any copyrights, patents or other industrial or intellectual property rights. Silergy makes no representation or warranty that any license, either express or implied, is granted under any patent right, copyright, mask work right, or other intellectual property right. Information published by Silergy regarding third-party products or services does not constitute a license to use such products or services or a warranty or endorsement thereof. Use of such information may require a license from a third party under the patents or other intellectual property of the third party, or a license from Silergy under the patents or other intellectual property of Silergy.

For more information, please visit: [www.silergy.com](http://www.silergy.com)

© 2019 Silergy Corp.

**All Rights Reserved.**