

Qxx30xHx & Qxx35xHx Series

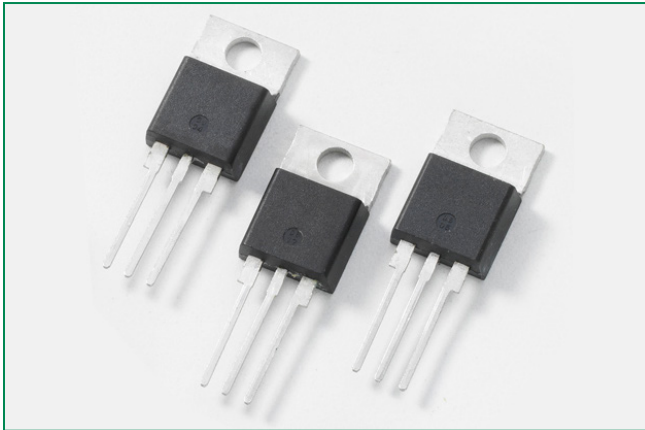

Agency Approval

Agency	Agency File Number
	E71639*

* - L Package and 30A only.

Main Features

Symbol	Value	Unit
$I_{T(RMS)}$	30 or 35	A
V_{DRM}/V_{RRM}	400 or 600	V
$I_{GT(Q1)}$	25 or 50	mA

Schematic Symbol

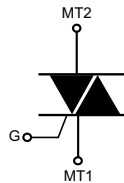

Description

The 30 Amp / 35 Amp bi-directional solid state switch series is designed for AC switching and phase control applications such as motor speed and temperature modulation controls, lighting controls, and static switching relays.

Standard type components normally operate in Quadrants I & III triggered from AC line.

Standard alternistor triac components operate with in-phase signals in Quadrants I or III and ONLY unipolar negative gate pulses for Quadrant II or III. The alternistor triac will not operate in Quadrant IV. These are used in circuit applications requiring a high dv/dt capability.

Features & Benefits

- RoHS Compliant
- Glass – passivated junctions
- Voltage capability up to 800V
- Surge capability up to 350A at 60 Hz half cycle
- L-Package isolation rating of 2500V rms

Applications

Excellent for AC switching and phase control applications such as heating, lighting, and motor speed controls.

Typical applications are AC solid-state switches, industrial power tools, exercise equipment, white goods and commercial appliances.

Alternistor Triacs (no snubber required) are used in applications with extremely inductive loads requiring highest commutation performance.

Internally constructed isolated packages are offered for ease of heat sinking with highest isolation voltage.

Additional Information



Datasheet



Resources



Samples

Absolute Maximum Ratings — Alternistor Triac (3 Quadrants)

Symbol	Parameter	Value	Unit		
$I_{T(RMS)}$	RMS on-state current (full sine wave)	Qxx35RH5/Qxx35NH5 $T_c = 90^\circ\text{C}$	35	A	
		Qxx30LH5/Qxx30LH3 $T_c = 50^\circ\text{C}$	30		
I_{TSM}	Non repetitive surge peak on-state current (full cycle, T_J initial = 25°C)	f = 50 Hz t = 20 ms	290	A	
		f = 60 Hz t = 16.7 ms	350		
I^2t	I^2t Value for fusing	-	$t_p = 8.3$ ms	508	A^2s
di/dt	Critical rate of rise of on-state current ($I_G = 200\text{mA}$ with $\leq 0.1\mu\text{s}$ rise time)	f = 120 Hz	$T_J = 125^\circ\text{C}$	100	$\text{A}/\mu\text{s}$
I_{GTM}	Peak gate trigger current	$t_p = 20\mu\text{s}$	$T_J = 125^\circ\text{C}$	4	A
$P_{G(AV)}$	Average gate power dissipation		$T_J = 125^\circ\text{C}$	0.5	W
T_{stg}	Storage temperature range			-40 to 125	$^\circ\text{C}$
T_J	Operating junction temperature range			-25 to 125	$^\circ\text{C}$

Electrical Characteristics ($T_J = 25^\circ\text{C}$, unless otherwise specified) — Alternistor Triac (3 Quadrants)

Symbol	Test Conditions	Quadrant	Qxx35RH5 Qxx35NH5 Qxx30LH5	Qxx30LH3	Unit	
I_{GT}	$V_D = 12\text{V}$ $R_L = 30\ \Omega$	I – II – III	MAX.	50	25	mA
V_{GT}	$V_D = 12\text{V}$ $R_L = 30\ \Omega$	I – II – III	MAX.	2	2	V
V_{GD}	$V_D = V_{DRM}$ $R_L = 3.3\ \text{k}\Omega$ $T_J = 125^\circ\text{C}$	I – II – III	MIN.	0.2	0.2	V
I_H	$I_T = 400\text{mA}$		MAX.	75	40	mA
dv/dt	$V_D = V_{DRM}$ Gate Open $T_J = 125^\circ\text{C}$	400V 600V	MIN.	475 400	350 250	$\text{V}/\mu\text{s}$
(dv/dt)c	(di/dt)c = 18.9 A/ms $T_J = 125^\circ\text{C}$		MIN.	20	10	$\text{V}/\mu\text{s}$
t_{gt}	35A device $I_G = 2 \times I_{GT}$ PW = 15 μs $I_T = 49.5\text{A(pk)}$ 30A device $I_G = 2 \times I_{GT}$ PW = 15 μs $I_T = 42.4\text{A(pk)}$		TYP.	3	3	μs

Note: xx = voltage/10

Static Characteristics

Symbol	Test Conditions				Value	Unit
V_{TM}	35A device $I_{TM} = 49.5A$ $t_p = 380 \mu s$				MAX.	1.5
	30A device $I_{TM} = 42.4A$ $t_p = 380 \mu s$					1.4
I_{DRM} I_{RRM}	$V_D = V_{DRM}/V_{RRM}$	Qxx35R/NH5	$T_J = 25^\circ C$	400 - 600V	MAX.	10
		Qxx30LH5 Qxx30LH3	$T_J = 125^\circ C$	400 - 600V		2

Thermal Resistances

Symbol	Parameter		Value	Unit
$R_{\theta(J-C)}$	Junction to case (AC)	Qxx35RH5 / Qxx35NH5	0.85	-
		Qxx30LH5 / Qxx30LH3	2.30	-
$R_{\theta(J-A)}$	Junction to ambient	Qxx35RH5	45	$^\circ C/W$
		Qxx30LH5 / Qxx30LH3	50	$^\circ C/W$

Note: xx = voltage/10

Figure 1: Definition of Quadrants

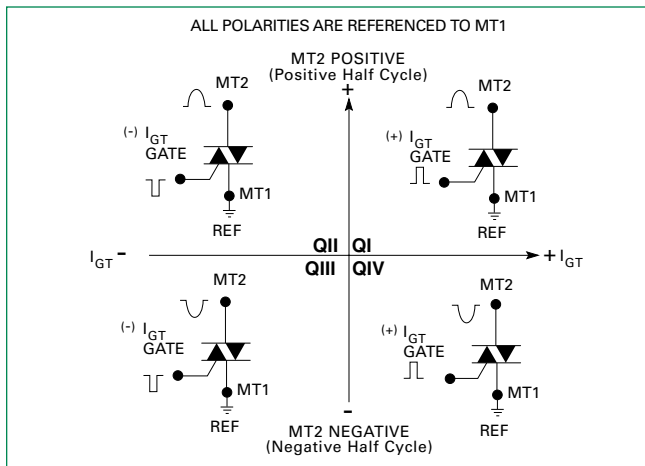

Note: Alternistors will not operate in QIV

Figure 2: Normalized DC Gate Trigger Current for All Quadrants vs. Junction Temperature

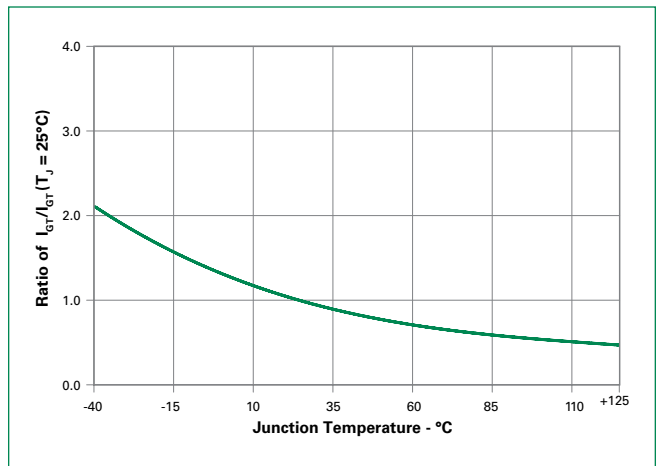

Figure 3: Normalized DC Holding Current vs. Junction Temperature

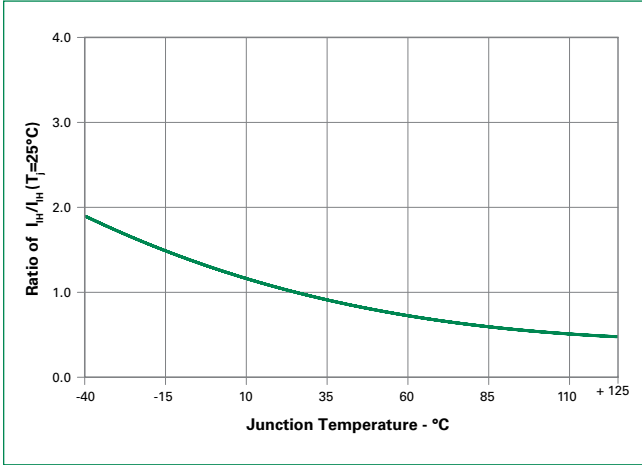

Figure 4: Normalized DC Gate Trigger Voltage for All Quadrants vs. Junction Temperature

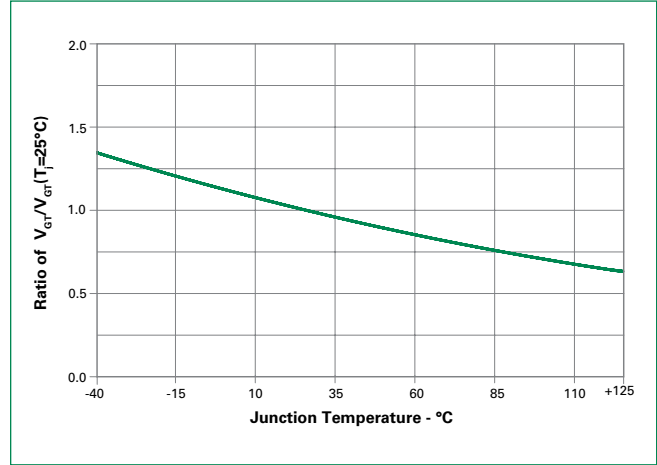

Figure 5: Power Dissipation (Typical) vs. RMS On-State Current

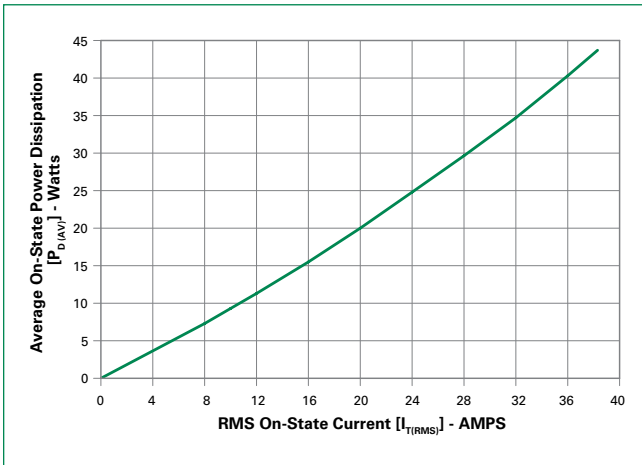
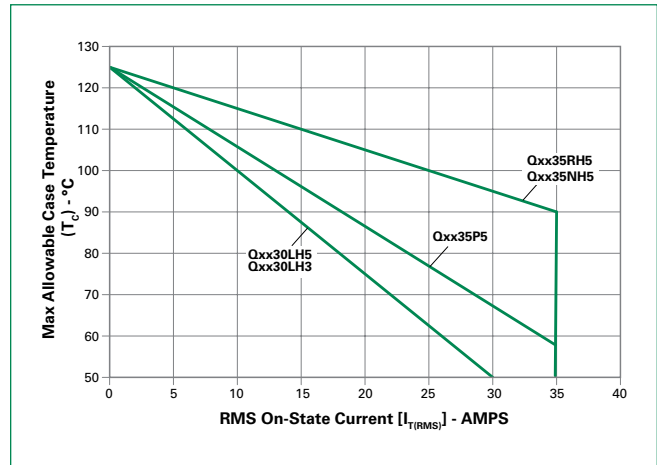

Figure 6: Maximum Allowable Case Temperature vs. On-State Current



Note: xx = voltage

Figure 7: On-State Current vs. On-State Voltage (Typical)

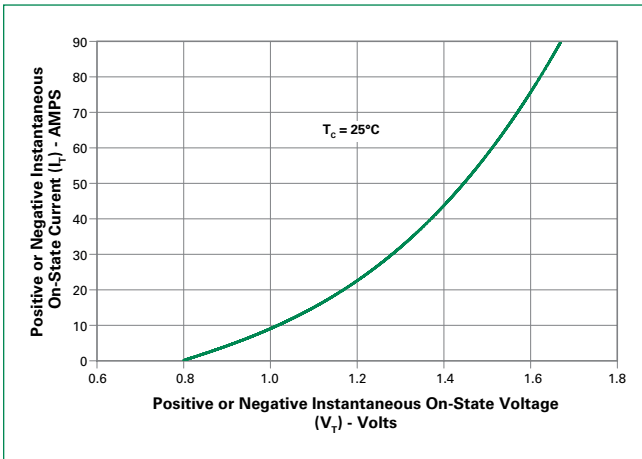
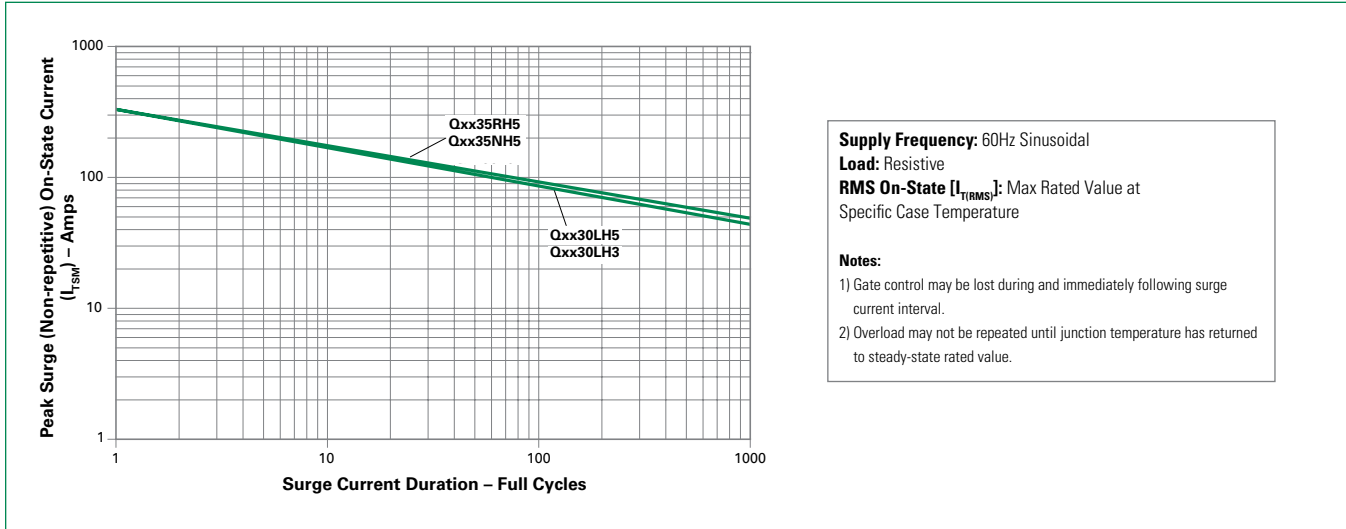

Figure 8: Surge Peak On-State Current vs. Number of Cycles



Note: xx = voltage

Soldering Parameters

Reflow Condition		Pb – Free assembly
Pre Heat	- Temperature Min ($T_{s(min)}$)	150°C
	- Temperature Max ($T_{s(max)}$)	200°C
	- Time (min to max) (t_s)	60 – 180 secs
Average ramp up rate (Liquidus Temp) (T_L) to peak		5°C/second max
$T_{S(max)}$ to T_L - Ramp-up Rate		5°C/second max
Reflow	- Temperature (T_L) (Liquidus)	217°C
	- Time (min to max) (t_s)	60 – 150 seconds
Peak Temperature (T_p)		260 ^{+0/-5} °C
Time within 5°C of actual peak Temperature (t_p)		20 – 40 seconds
Ramp-down Rate		5°C/second max
Time 25°C to peak Temperature (T_p)		8 minutes Max.
Do not exceed		280°C

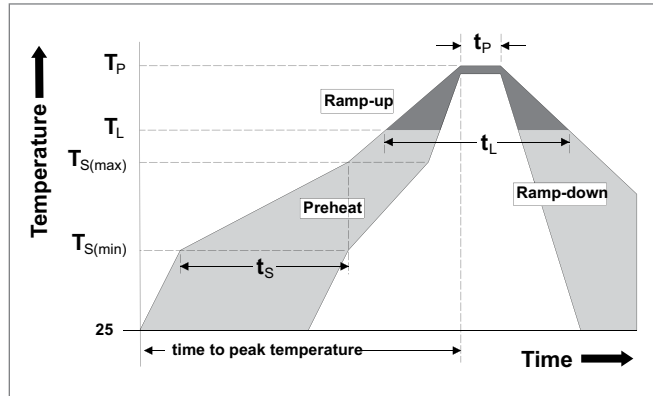

Physical Specifications

Terminal Finish	100% Matte Tin-plated.
Body Material	UL Recognized compound meeting flammability rating V-0
Terminal Material	Copper Alloy

Design Considerations

Careful selection of the correct component for the application's operating parameters and environment will go a long way toward extending the operating life of the Thyristor. Good design practice should limit the maximum continuous current through the main terminals to 75% of the component rating. Other ways to ensure long life for a power discrete semiconductor are proper heat sinking and selection of voltage ratings for worst case conditions. Overheating, overvoltage (including dv/dt), and surge currents are the main killers of semiconductors. Correct mounting, soldering, and forming of the leads also help protect against component damage.

Environmental Specifications

Test	Specifications and Conditions
AC Blocking	MIL-STD-750, M-1040, Cond A Applied Peak AC voltage @ 125°C for 1008 hours
Temperature Cycling	MIL-STD-750, M-1051, 100 cycles; -40°C to +150°C; 15-min dwell-time
Temperature/Humidity	EIA / JEDEC, JESD22-A101 1008 hours; 320V - DC: 85°C; 85% rel humidity
High Temp Storage	MIL-STD-750, M-1031, 1008 hours; 150°C
Low-Temp Storage	1008 hours; -40°C
Thermal Shock	MIL-STD-750, M-1056 10 cycles; 0°C to 100°C; 5-min dwell-time at each temperature; 10 sec (max) transfer time between temperature
Autoclave	EIA / JEDEC, JESD22-A102 168 hours (121°C at 2 ATMs) and 100% R/H
Resistance to Solder Heat	MIL-STD-750 Method 2031
Solderability	ANSI/J-STD-002, category 3, Test A
Lead Bend	MIL-STD-750, M-2036 Cond E

Dimensions — TO-220AB (R-Package) — Non-Isolated Mounting Tab Common with Center Lead

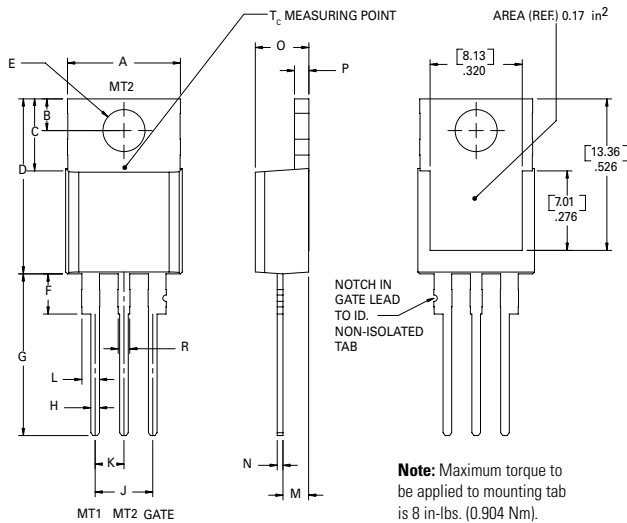

Dimension	Inches		Millimeters	
	Min	Max	Min	Max
A	0.380	0.420	9.65	10.67
B	0.105	0.115	2.67	2.92
C	0.230	0.250	5.84	6.35
D	0.590	0.620	14.99	15.75
E	0.142	0.147	3.61	3.73
F	0.110	0.130	2.79	3.30
G	0.540	0.575	13.72	14.61
H	0.025	0.035	0.64	0.89
J	0.195	0.205	4.95	5.21
K	0.095	0.105	2.41	2.67
L	0.060	0.075	1.52	1.91
M	0.085	0.095	2.16	2.41
N	0.018	0.024	0.46	0.61
O	0.178	0.188	4.52	4.78
P	0.045	0.060	1.14	1.52
R	0.038	0.048	0.97	1.22

Dimensions — TO-220AB (L-Package) — Isolated Mounting Tab

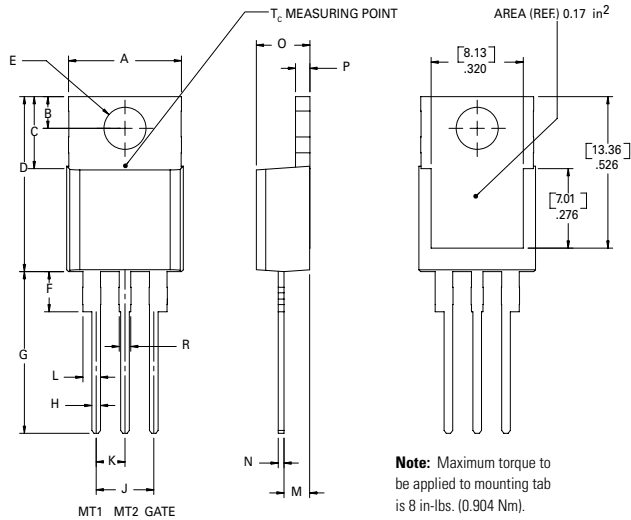

Dimension	Inches		Millimeters	
	Min	Max	Min	Max
A	0.380	0.420	9.65	10.67
B	0.105	0.115	2.67	2.92
C	0.230	0.250	5.84	6.35
D	0.590	0.620	14.99	15.75
E	0.142	0.147	3.61	3.73
F	0.110	0.130	2.79	3.30
G	0.540	0.575	13.72	14.61
H	0.025	0.035	0.64	0.89
J	0.195	0.205	4.95	5.21
K	0.095	0.105	2.41	2.67
L	0.060	0.075	1.52	1.91
M	0.085	0.095	2.16	2.41
N	0.018	0.024	0.46	0.61
O	0.178	0.188	4.52	4.78
P	0.045	0.060	1.14	1.52
R	0.038	0.048	0.97	1.22

Dimensions — TO-263 (N-Package) — D² Pak Surface Mount

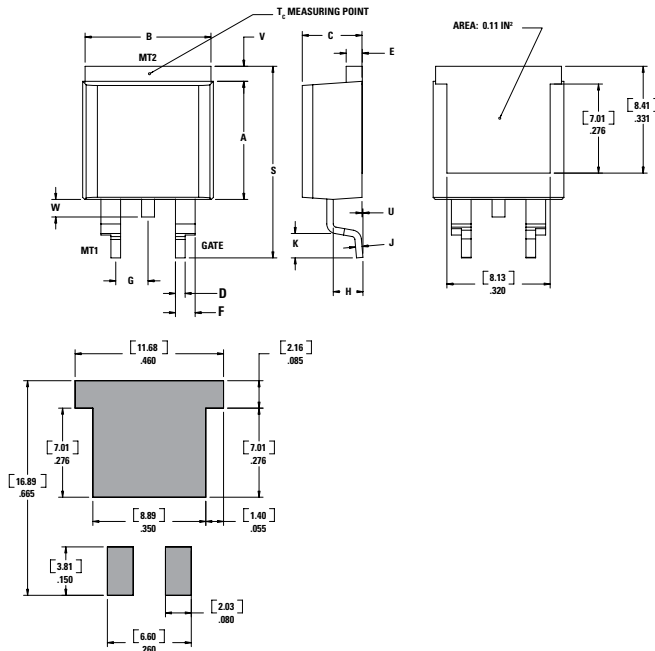

Dimension	Inches		Millimeters	
	Min	Max	Min	Max
A	0.360	0.370	9.14	9.40
B	0.380	0.420	9.65	10.67
C	0.178	0.188	4.52	4.78
D	0.025	0.035	0.64	0.89
E	0.045	0.060	1.14	1.52
F	0.060	0.075	1.52	1.91
G	0.095	0.105	2.41	2.67
H	0.092	0.102	2.34	2.59
J	0.018	0.024	0.46	0.61
K	0.090	0.110	2.29	2.79
S	0.590	0.625	14.99	15.88
V	0.035	0.045	0.89	1.14
U	0.002	0.010	0.05	0.25
W	0.040	0.070	1.016	1.78

Product Selector

Part Number	Voltage			Gate Sensitivity Quadrants		I _{T(RMS)}	Type	Package
	400V	600V	800V	I – II – III	IV			
Qxx35RH5	X	X		50 mA		35A	Alternistor Triac	TO-220R
Qxx35NH5	X	X		50 mA		35A	Alternistor Triac	TO-263 D ² -PAK
Qxx30LH5	X	X		50 mA		30A	Alternistor Triac	TO-220L
Qxx30LH3	X	X		25 mA		30A	Alternistor Triac	TO-220L

Note: xx = Voltage/10

Packing Options

Part Number	Marking	Weight	Packing Mode	Base Quantity
Qxx35RH5TP	Qxx35RH5	2.20 g	Tube	1000 (50 per tube)
Qxx35NH5TP	Qxx35NH5	1.60 g	Tube	1000 (50 per tube)
Qxx35NH5RP	Qxx35NH5	1.60 g	Embossed Carrier	500
Qxx30LH5TP	Qxx30LH5	2.20 g	Tube	1000 (50 per tube)
Qxx30LH3TP	Qxx30LH3	2.20 g	Tube	1000 (50 per tube)

xx = voltage/10

Part Numbering System

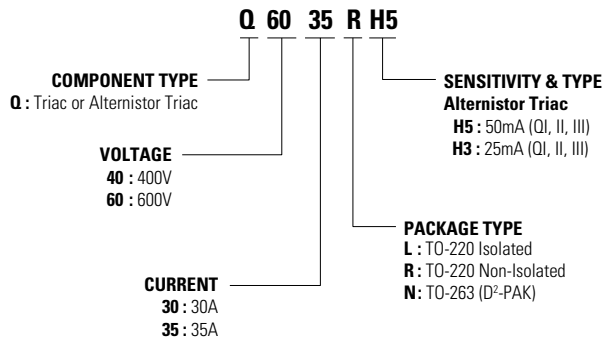

Part Marking System

TO-220 AB - (L and R Package)
TO-263 AB - (N Package)

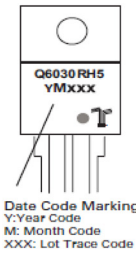

TO-263 Embossed Carrier Reel Pack (RP) Specifications

Meets all EIA-481-2 Standards

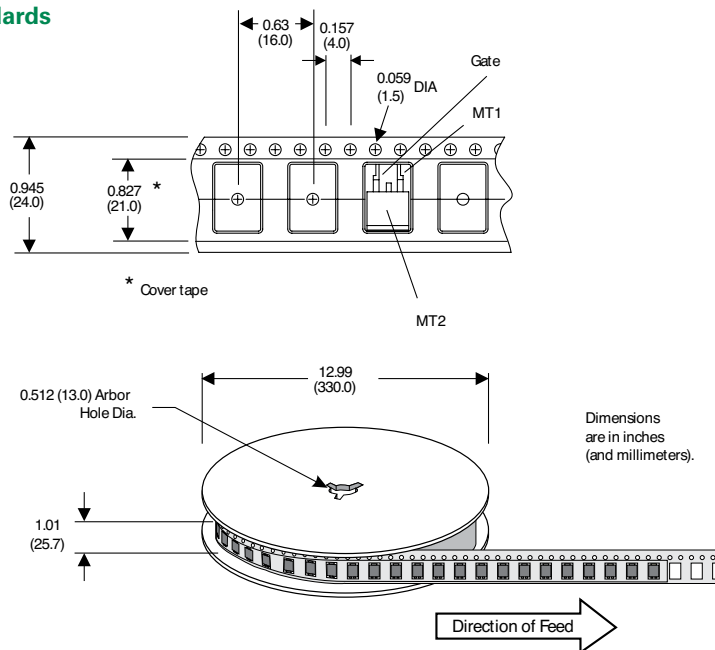

Disclaimer Notice - Information furnished is believed to be accurate and reliable. However, users should independently evaluate the suitability of and test each product selected for their own applications. Littelfuse products are not designed for, and may not be used in, all applications. Read complete Disclaimer Notice at <http://www.littelfuse.com/disclaimer-electronics>.

©2019 Littelfuse, Inc
Specifications are subject to change without notice.
Revised: B0.12/10/20

Mouser Electronics

Authorized Distributor

Click to View Pricing, Inventory, Delivery & Lifecycle Information:

[Littelfuse:](#)

[Q6035PH5-E](#) [Q6035PH5-D](#) [Q6035PH5-W](#) [Q6035PH5-C](#)