

DESCRIPTION

The MP24893 is a high efficiency step-down converter designed in continuous current mode for driving the high brightness LEDs from wide input voltage of 6V to 36V.

The MP24893 employs hysteretic control architecture to regulate a highly accurate LED current, which is measured through an external high-side current-sense resistor. Moreover, this control scheme provides optimal circuit stabilization and a very quick response time without loop compensation. Its low 200mV average feedback voltage reduces power loss and improves the converter efficiency.

The MP24893 implements PWM and analog dimming together through the DIM pin.

The MP24893 includes under-voltage lockout, thermal overload protection to prevent damage in the event of an output overload.

The MP24893 is available in TSOT23-5 and QFN6 packages.

FEATURES

- Internal 36V MOSFET
- Wide 6V-to-36V Input Range
- 1A Output Current
- High Efficiency
- Hysteretic Control
- PWM and Analog Dimming
- 1000:1 PWM Dimming Resolution
- UVLO, Thermal Shutdown
- Available in TSOT23-5 and QFN6 Packages

APPLICATIONS

- Low-Voltage Halogen Replacement
- Low-Voltage General Illumination
- Automotive/Decorative LED Lighting
- Signs/Emergency Lighting
- LED Backlighting

All MPS parts are lead-free and adhere to the RoHS directive. For MPS green status, please visit MPS website under Products, Quality Assurance page.

"MPS" and "The Future of Analog IC Technology" are registered trademarks of Monolithic Power Systems, Inc.

TYPICAL APPLICATION

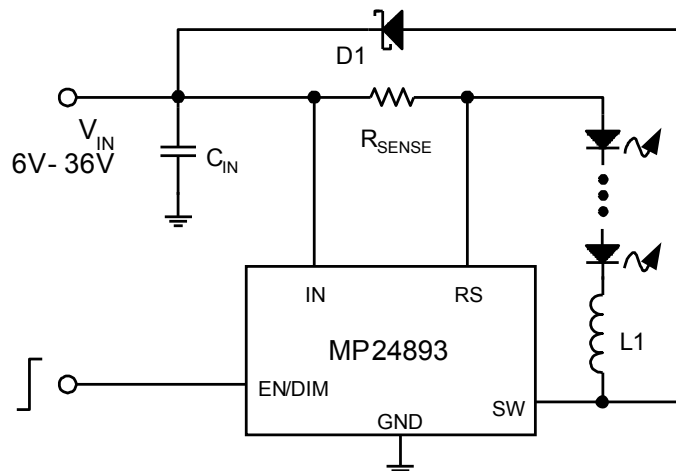

ORDERING INFORMATION

Part Number	Package	Top Marking
MP24893DJ*	TSOT23-5	ABD
MP24893DQ**	QFN6 (3x3mm)	ABD

* For Tape & Reel, add suffix -Z (e.g. MP24893DJ-Z);
 For RoHS Compliant Packaging, add suffix -LF (e.g. MP24893DJ-LF-Z)
 **For Tape & Reel, add suffix -Z (e.g. MP24893DQ-Z);
 For RoHS Compliant Packaging, add suffix -LF (e.g. MP24893DQ-LF-Z)

PACKAGE REFERENCE

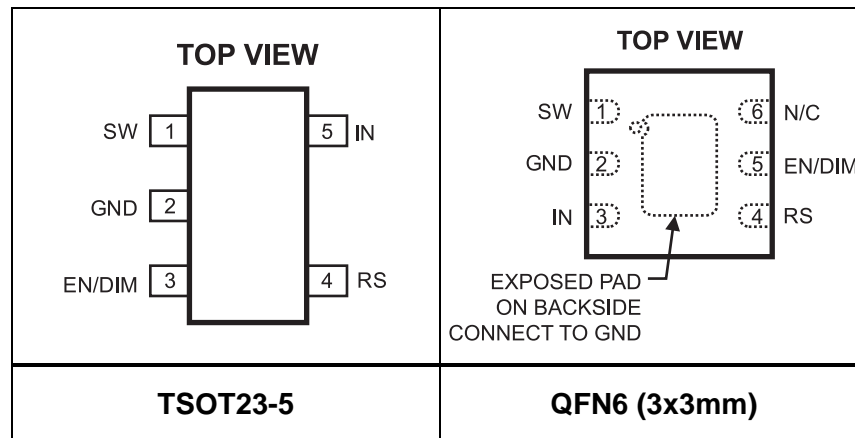

ABSOLUTE MAXIMUM RATINGS ⁽¹⁾

V_{IN}, V_{SW}	-0.3V to +40V
V_{RS}	$V_{IN}-5V$ to V_{IN}
All Other Pins	-0.3V to +6.3V
Continuous Power Dissipation ($T_A = +25^\circ C$) ⁽²⁾	
TSOT23-5	1.1W
QFN6 (3x3mm)	2.5W
Junction Temperature	150°C
Lead Temperature	260°C
Storage Temperature	-65°C to +150°C

Recommended Operating Conditions ⁽³⁾

Supply Voltage V_{IN}	6V to 36V
Operating Junction Temp. (T_J)	-40°C to +125°C

Thermal Resistance ⁽⁴⁾ θ_{JA} θ_{JC}

TSOT23-5	110	55	°C/W
QFN6 (3x3mm)	50	14	°C/W

Notes:

- Exceeding these ratings may damage the device.
- The maximum allowable power dissipation is a function of the maximum junction temperature $T_J(MAX)$, the junction-to-ambient thermal resistance θ_{JA} , and the ambient temperature T_A . The maximum allowable continuous power dissipation at any ambient temperature is calculated by $P_D(MAX) = (T_J(MAX) - T_A) / \theta_{JA}$. Exceeding the maximum allowable power dissipation will cause excessive die temperature, and the regulator will go into thermal shutdown. Internal thermal shutdown circuitry protects the device from permanent damage.
- The device is not guaranteed to function outside of its operation conditions.
- Measured on JESD51-7 4-layer board.

ELECTRICAL CHARACTERISTICS

$V_{IN} = 24V$, $T_A = +25^{\circ}C$, unless otherwise noted.

Parameter	Symbol	Condition	Min	Typ	Max	Units
Input Voltage	V_{IN}		6		36	V
IN Under-Voltage Lockout	V_{IN_UVLO}	V_{IN} Rising		5.3	5.9	V
Under-Voltage Lockout Hysteresis				700		mV
Shutdown Supply Current	I_{SD}			100	120	μA
Quiescent Supply Current	I_Q	No Switching		0.7	1	mA
Feedback Reference Voltage Peak (with respect to V_{IN})	$V_{IN-V_{RS}}$	$V_{EN/DIM} = 5V$	220	230	240	mV
Feedback Reference Voltage Valley (with respect to V_{IN})	$V_{IN-V_{RS}}$	$V_{EN/DIM} = 5V$	160	170	180	mV
EN/DIM Max. Dimming Voltage ⁽⁵⁾	V_{DIM_MAX}			2.56		V
EN/DIM Min. Dimming Voltage ⁽⁵⁾	V_{DIM_MIN}			0.3		V
EN/DIM Enable High Voltage	V_{EN_HIGH}	V_{EN} Rising	0.2	0.25	0.3	V
EN/DIM Enable Hysteresis	V_{EN_HYS}		20	50	80	mV
EN/DIM Pull-Up Resistor	R_{EN}			45		k Ω
Internal Reference Voltage	V_{REF}			1.275		V
Switch On Resistance	R_{DS_ON3}			0.2		Ω
Minimum On Time ⁽⁵⁾	t_{ON_MIN}			100		ns
Minimum Off Time ⁽⁵⁾	t_{OFF_MIN}			100		ns
Recommended Duty Cycle Range	D		30		70	%

Notes:

5) Guaranteed by design

PIN FUNCTIONS

TSOT23-5 Pin#	QFN6 (3x3mm) Pin#	Name	Description
1	1	SW	Drain of Internal MOSFET. Connect the inductor common terminal and Schottky anode to this pin.
2	2	GND	Ground.
3	5	EN/DIM	Enable/Dimming Command Input. For PWM dimming, apply a square wave signal to this pin. For analog dimming, apply a 0.3V-to-2.5V DC voltage to linearly control the LED current range from 25% to 200%. Turn off the output current when pulling this pin below 0.2V. Leave it open for normal operation ($V_{EN/DIM}=1.28V$).
4	4	RS	LED Current Sense Input. Connect a current-sense resistor to program the LED average current to IN pin.
5	3	IN	Input Supply Pin. Connect an appropriate decoupling capacitor from the IN pin to GND.
	6	N/C	Not Connected.

TYPICAL PERFORMANCE CHARACTERISTICS

$V_{IN}=24V$, 3 LEDs in series, $I_{OUT}=1A$, unless otherwise noted.

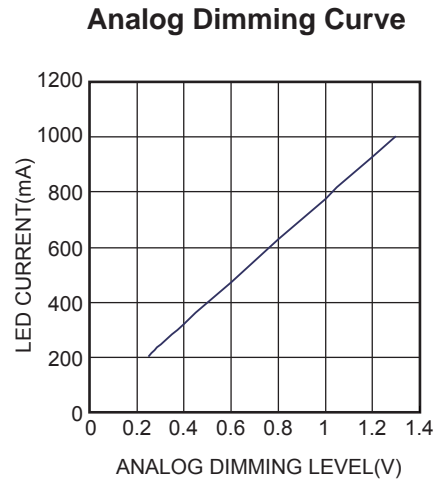
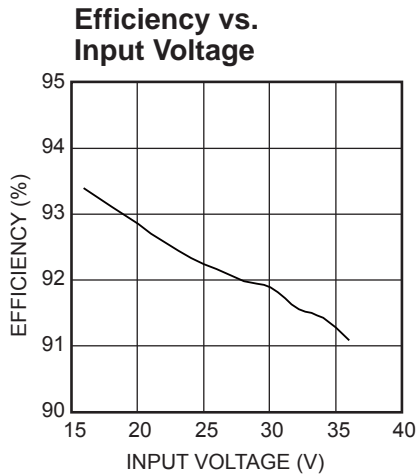

Steady State

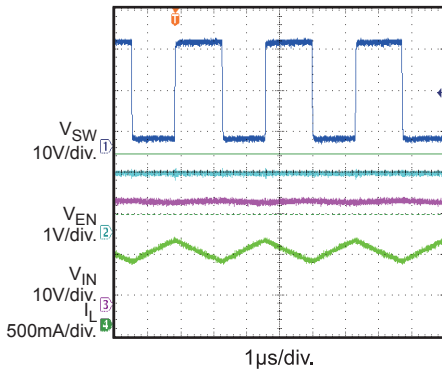

V_{IN} Startup

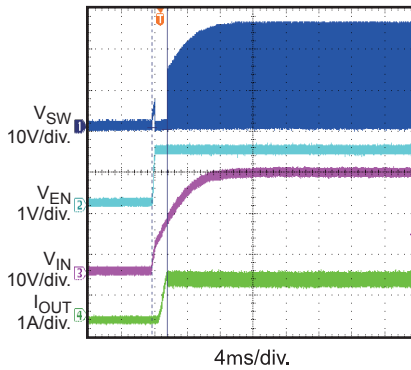

V_{EN} Startup

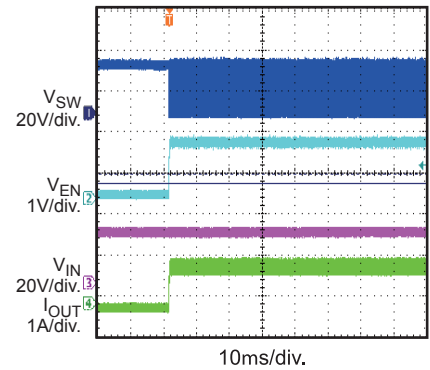

PWM Dimming

$f_{PWM} = 200Hz$, $D_{PWM} = 50\%$

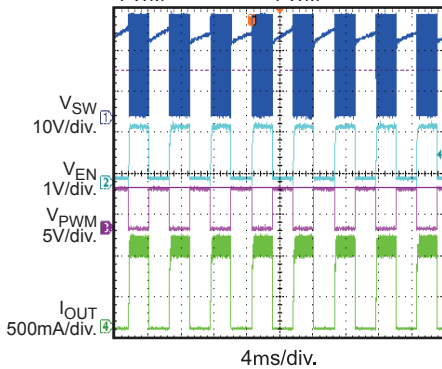

Open LED Protection

Open LEDs at working

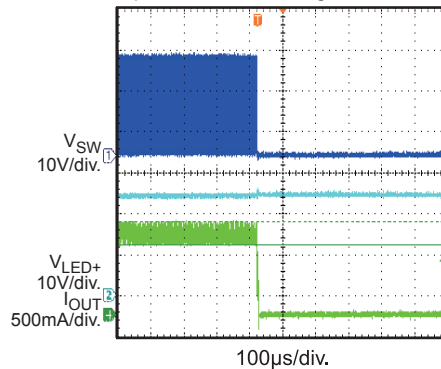

Short LED Protection

Short LEDs at working

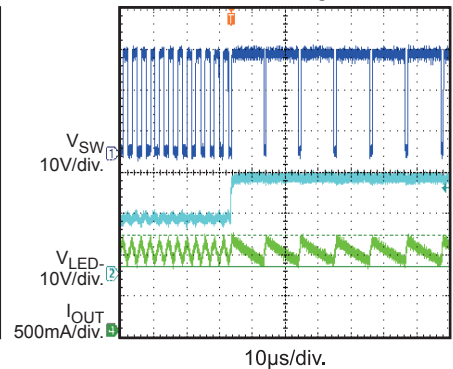

FUNCTION DIAGRAM

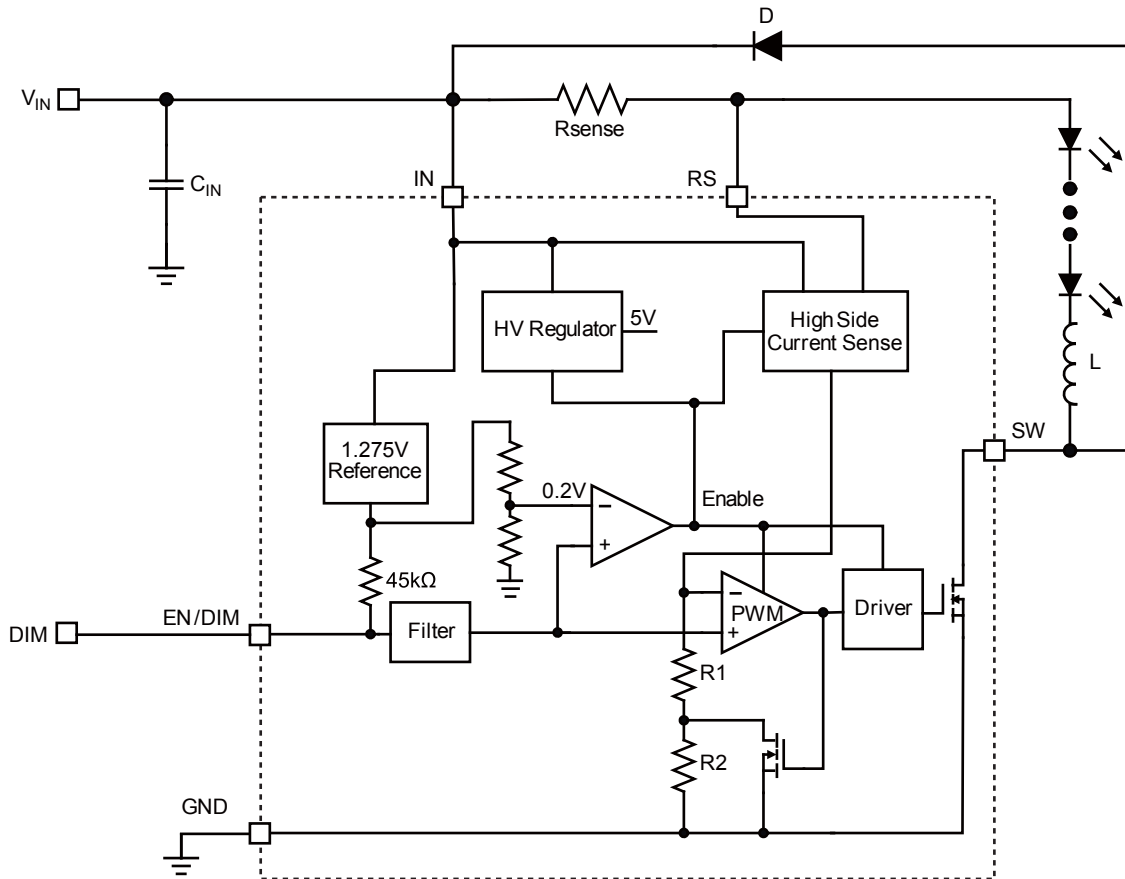

Figure 1: MP24893 Functional Block Diagram

OPERATION

Steady State

The MP24893 is a hysteretic-controlled, step-down LED driver that is easily configured for various applications with an input range from 6V to 36V. The converter employs a high-side current-sense resistor to detect and regulate the LED current. The voltage across the current-sense resistor is measured and regulated to within $202\text{mV} \pm 30\text{mV}$.

The internal 1.275V reference voltage provides a 0.2V reference to enable the part and a 1.275V pull-up voltage as current reference. When $V_{\text{EN}} > 0.2\text{V}$, the output of the comparator goes high and the other blocks are enabled.

A high-side resistor, R_{SENSE} , senses the output current. When the switch is on, R2 is shorted and R1 sets the output current upper-threshold. When the switch is off, R1 and R2 set the output current lower-threshold, and the ratio of R1 and R2 determines the current hysteresis.

Enable Control

Once Input voltage is applied, the internal 1.275V reference is connected to EN/DIM pin through pull up resistor. If the EN/DIM pin is left open, the IC will automatically start up to the maximum brightness. Adding a capacitor to this pin can hereby program a soft-start time.

Applying an external voltage range from 0.2V to 1.25V to the EN/DIM pin linearly controls the current-sense voltage reference from 0mV to 202mV for analog dimming.

Applying an external PWM voltage with an amplitude of 1.25V to the EN/DIM pin achieves PWM dimming. For additional information on the flexible external PWM dimming method, please refer to the “Selecting Dimming Control Mode” section.

System Soft Start

The voltage on the EN/DIM pin is the inductor current reference. An external capacitor from the EN/DIM pin to ground provides a soft-start delay. When V_{IN} starts, internal voltage source charges the capacitor from 0V to 1.25V for soft-start.

Dimming Control

MP24893 provides two dimming methods: PWM dimming and DC analog dimming.

To use PWM dimming, apply a square wave to the EN/DIM pin. To use analog dimming, apply a 0.3V-to-2.5V DC voltage to this pin.

APPLICATION INFORMATION

Setting the LED Current

The LED current is set by the current-setting resistor between the IN and RS pins, where:

$$R_{SET} = 202\text{mV}/I_{LED}$$

For $R_{SET} = 0.36\Omega$, the LED current is set to 550mA

Selecting the Inductor

Lower values of the inductor result in higher switching frequencies, leading to larger switch loss. For most applications, select a switching frequency between 200kHz and 600kHz. Estimate the inductor value based on the desired switching frequency, where:

$$L = \frac{(1 - \frac{V_{OUT}}{V_{IN}}) \times V_{OUT}}{0.3 \times I_{LED} \times f_{SW}}$$

For higher efficiency, use inductors with low DC resistance.

Selecting the Diode

The output diode supplies current to the inductor when the internal MOSFET is off. To reduce losses due to the diode forward voltage and recovery time, use a Schottky diode. Select a diode rated with a reverse voltage greater than the input voltage. The average current rating must be exceeded the maximum expected load current, and the peak current rating must exceed the peak inductor current.

Selecting the Input Capacitor

The input capacitor reduces the surge current drawn from the input supply and the switching noise from the device. Select capacitor value between 10 μ F and 22 μ F for most applications. The voltage rating should exceed the input voltage. Use a low-ESR capacitor input decoupling.

Selecting the Output Capacitor

For most applications, an output capacitor is not necessary. But if the peak-to-peak ripple LED current must be less than 30% of the average current, add a capacitor across the LEDs, where a higher capacitor value leads to a proportionally lower ripple. A 2.2 μ F capacitor will meet most requirements.

Selecting Soft-Start Capacitor

The delay time with the soft-start capacitor can be estimated by 0.2ms/nF. In PWM dimming, select a $C < 2.2\text{nF}$ to eliminate its effect on the average LED current.

Selecting Dimming Control Mode

MP24893 provides two dimming methods: DC analog dimming and PWM dimming.

1. DC analog dimming mode

Apply a 0.3V-to-2.5V DC voltage to the EN/DIM pin. The voltage from 0.3V to 2.5V changes the inductor current reference directly and linearly controls the inductor current range from 25% to 200% (see Figure 2).

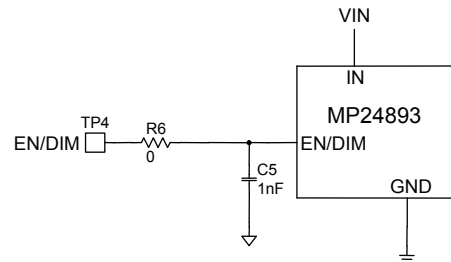

Figure 2: Analog Dimming External Circuit

2. PWM dimming mode

Apply a 100Hz-to-2kHz square waveform to the EN/DIM pin. The average LED current is proportional to the PWM duty cycle. Add an NPN-transistor on/off circuit to separate the PWM signal from the current reference (see Figure 3) because this pin is pulled up by the 1.25V internal source as the inductor current reference. The minimum PWM amplitude is 1.5V.

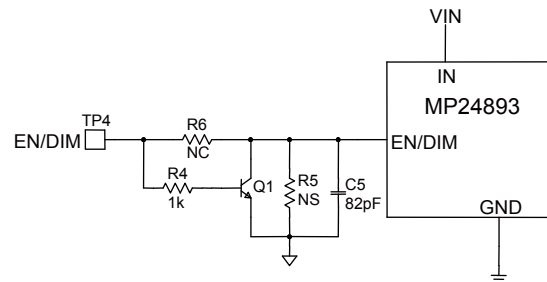
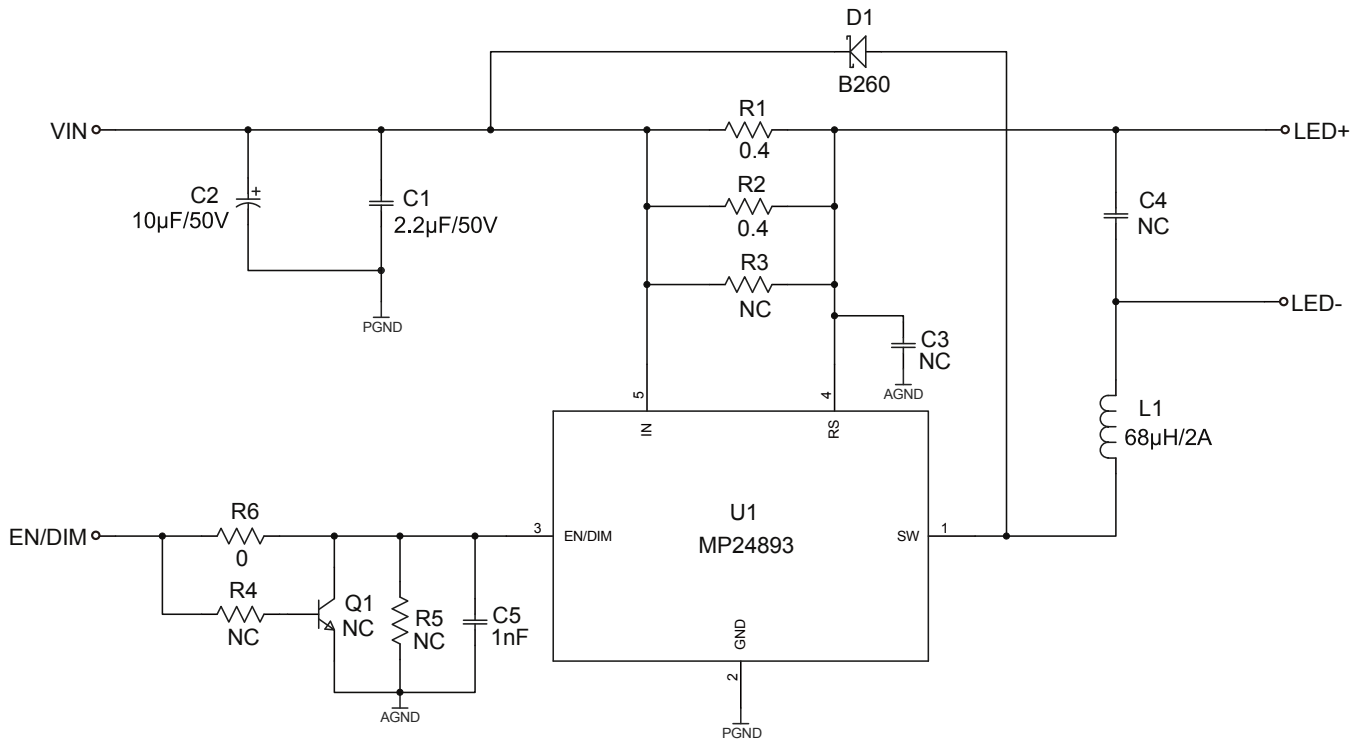

Figure 3: PWM Dimming External Circuit

Circuit Layout Consideration

Pay careful attention to the PCB board layout and components placement. R_{SENSE} should be placed close to the IN pin and RS pin to minimize set current error. The input loop—including the input capacitor, Schottky diode, and internal MOSFET—should be as short as possible.

TYPICAL APPLICATION CIRCUIT

Figure 4: Drive 3 LEDs in Series, 1A Current Output

PACKAGE INFORMATION

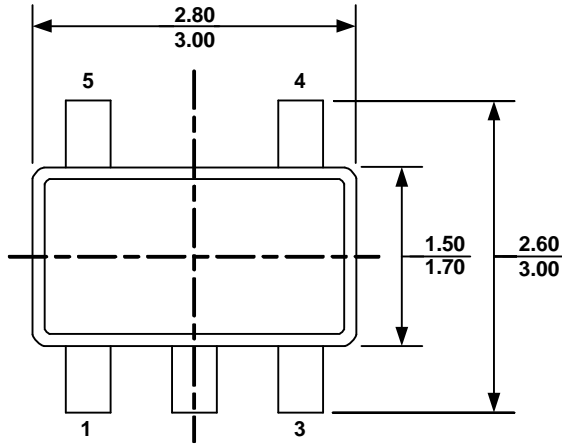
TSOT23-5

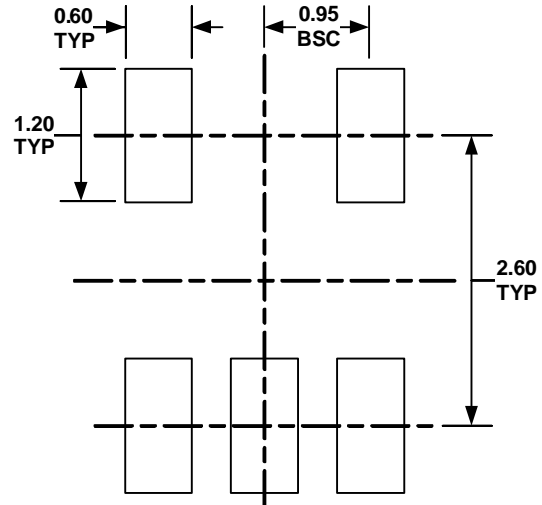

TOP VIEW



RECOMMENDED LAND PATTERN

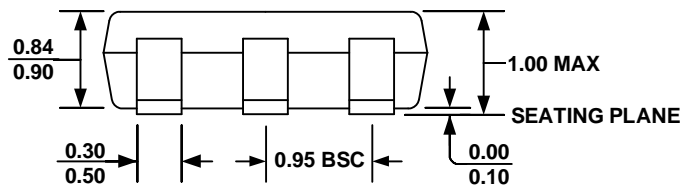

FRONT VIEW

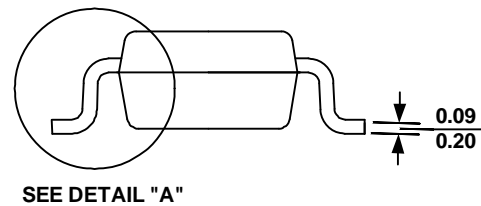

SIDE VIEW

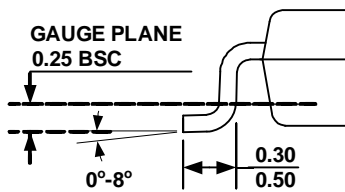

DETAIL 槽

NOTE:

- 1) ALL DIMENSIONS ARE IN MILLIMETERS
- 2) PACKAGE LENGTH DOES NOT INCLUDE MOLD FLASH, PROTRUSION OR GATE BURR.
- 3) PACKAGE WIDTH DOES NOT INCLUDE INTERLEAD FLASH OR PROTRUSION.
- 4) LEAD COPLANARITY (BOTTOM OF LEADS AFTER FORMING) SHALL BE 0.10 MILLIMETERS MAX.
- 5) DRAWING CONFORMS TO JEDEC MO-193, VARIATION AA.
- 6) DRAWING IS NOT TO SCALE.

QFN6 (3x3mm)

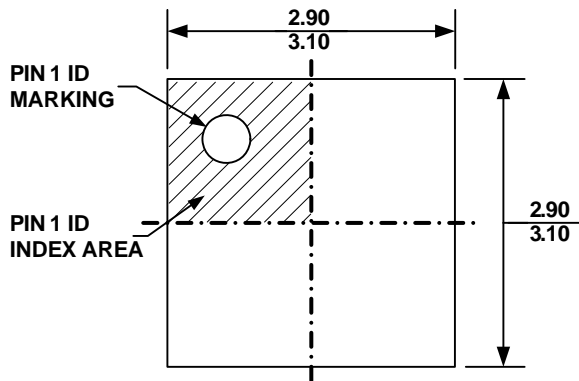

TOP VIEW

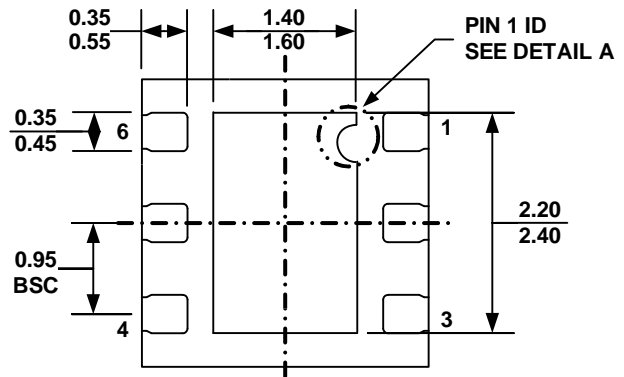

BOTTOM VIEW

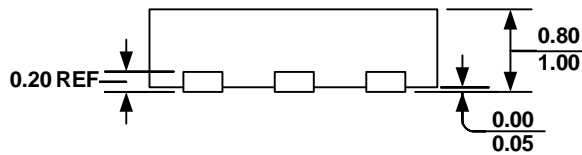

SIDE VIEW

**PIN 1 ID OPTION A
R0.20 TYP.**

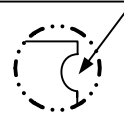

**PIN 1 ID OPTION B
R0.20 TYP.**

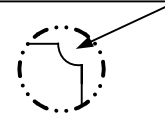

DETAIL A

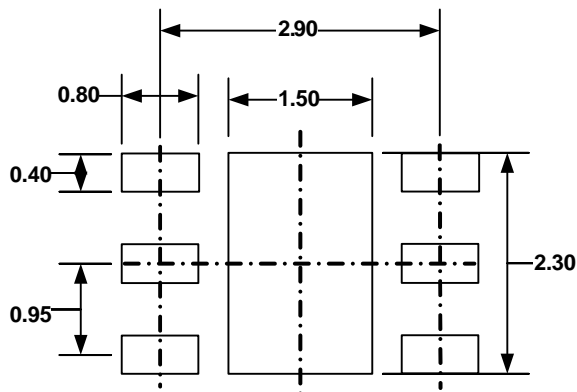

RECOMMENDED LAND PATTERN

NOTE:

- 1) ALL DIMENSIONS ARE IN MILLIMETERS
- 2) EXPOSED PADDLE SIZE DOES NOT INCLUDE MOLD FLASH
- 3) LEAD COPLANARITY SHALL BE 0.10 MILLIMETER MAX
- 4) JEDEC REFERENCE IS MO-229, VARIATION VEEA-2.
- 5) DRAWING IS NOT TO SCALE

NOTICE: The information in this document is subject to change without notice. Users should warrant and guarantee that third party Intellectual Property rights are not infringed upon when integrating MPS products into any application. MPS will not assume any legal responsibility for any said applications.

Mouser Electronics

Authorized Distributor

Click to View Pricing, Inventory, Delivery & Lifecycle Information:

[Monolithic Power Systems \(MPS\):](#)

[MP24893DQ-LF-Z](#) [MP24893DJ-LF-P](#) [MP24893DQ-LF-P](#) [MP24893DJ-LF-Z](#)