

## DESCRIPTION

The MPM3804 is a DC/DC module that includes a monolithic, step-down, switch-mode converter with built-in, internal power MOSFETs and an inductor. The MPM3804 achieves 0.6A of continuous output current from a 2.3V to 5.5V input voltage range with excellent load and line regulation. The output voltage can be regulated as low as 0.6V. Only input capacitors, output capacitors, and feedback (FB) resistors are required to complete the design.

The constant-on-time (COT) control scheme provides a fast transient response, high light-load efficiency, and easy loop stabilization.

Full protection features include cycle-by-cycle current limiting and thermal shutdown.

The MPM3804 is ideal for a wide range of applications, including high-performance DSPs, wireless power, portable and mobile devices, and other low-power systems.

The MPM3804 requires a minimal number of readily available, standard, external components and is available in an ultra-small QFN-10 (2mmx2mm) package.

## FEATURES

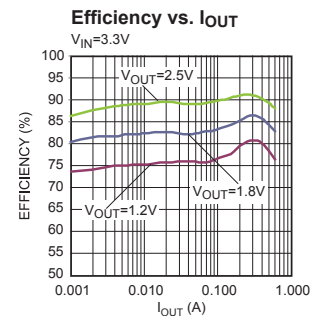
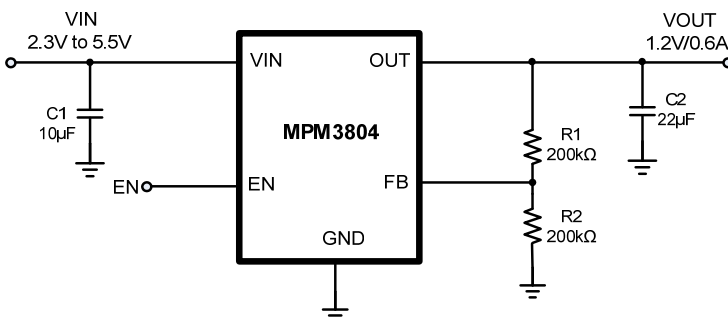
- Up to 91% Peak Efficiency
- Low  $I_Q$ : 11 $\mu$ A
- Wide 2.3V to 5.5V Operating Input Range
- Output Voltage as Low as 0.6V
- 100% Duty Cycle in Dropout
- 0.6A Output Current
- 120m $\Omega$  and 80m $\Omega$  Internal Power MOSFETs
- 2.4MHz Frequency
- EN and Power Good for Power Sequencing
- Cycle-by-Cycle Over-Current Protection (OCP)
- 0.5ms Internal Soft-Start Time
- Output Discharge
- Short-Circuit Protection (SCP) with Hiccup Mode
- Thermal Shutdown
- Stable with Low ESR Output Ceramic Capacitors
- Ultra-Small 2mm x 2mm x 0.9mm QFN-10 Package

## APPLICATIONS

- Optical Modules
- Industrial Products
- IOT Devices
- Space Constrained Applications
- Low-Voltage I/O Supplies
- LDO Replacement

All MPS parts are lead-free, halogen-free, and adhere to the RoHS directive. For MPS green status, please visit the MPS website under Quality Assurance. "MPS" and "The Future of Analog IC Technology" are registered trademarks of Monolithic Power Systems, Inc.

## TYPICAL APPLICATION



### ORDERING INFORMATION

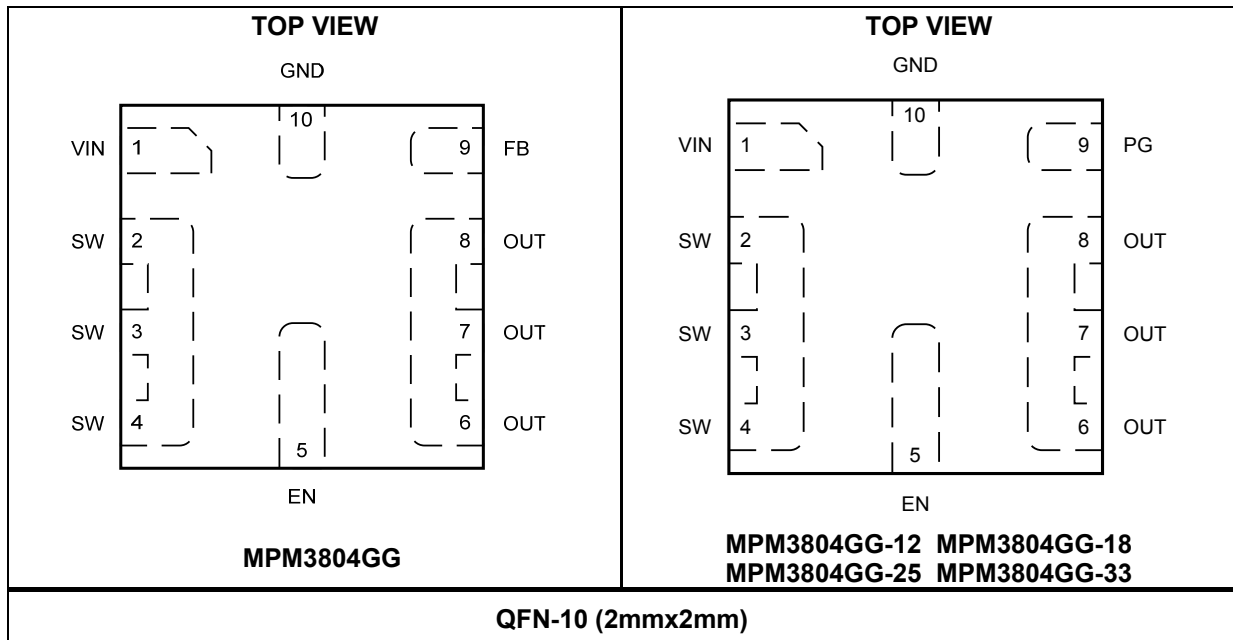
Part Number	Package	Top Marking	MSL Rating
MPM3804GG*	QFN-10 (2mmx2mm)	See Below	3
MPM3804GG-12*			
MPM3804GG-18*			
MPM3804GG-25*			
MPM3804GG-33*			

\* For Tape & Reel, Add Suffix -Z (e.g. MPM3804GG-Z)

### TOP MARKING

DLY LLL	HFY LLL	JBY LLL	HMY LLL	HGY LLL
DL: Product code of MPM3804GG Y: Year code LLL: Lot number	HF: Product code of MPM3804GG-12 Y: Year code LLL: Lot number	JB: Product code of MPM3804GG-18 Y: Year code LLL: Lot number	HM: Product code of MPM3804GG-25 Y: Year code LLL: Lot number	HG: Product code of MPM3804GG-33 Y: Year code LLL: Lot number
<b>MPM3804GG</b>	<b>MPM3804GG-12</b>	<b>MPM3804GG-18</b>	<b>MPM3804GG-25</b>	<b>MPM3804GG-33</b>

### PACKAGE REFERENCE



**ABSOLUTE MAXIMUM RATINGS (1)**

Supply voltage (VIN).....	6V
V <sub>sw</sub> .....	-0.3V (-5V for <10ns) to 6V (8V for <10ns or 10V for <3ns)
All other pins .....	-0.3V to 6V
Junction temperature .....	150°C
Lead temperature.....	260°C
Continuous power dissipation (T <sub>A</sub> = +25°C) (2)	1.6W
Storage temperature.....	-65°C to +150°C

**ESD Rating**

Human-body model (HBM).....	2000V
Charged-device model (CDM).....	2000V

**Recommended Operating Conditions (3)**

Supply voltage (VIN).....	2.3V to 5.5V
Operating junction temp. (T <sub>J</sub> )....	-40°C to +125°C

<b>Thermal Resistance (4)</b>	<b>θ<sub>JA</sub></b>	<b>θ<sub>JC</sub></b>	
QFN-10 (2mmx2mm).....	80	16	... °C/W

**NOTES:**

- 1) Exceeding these ratings may damage the device.
- 2) The maximum allowable power dissipation is a function of the maximum junction temperature T<sub>J</sub> (MAX), the junction-to-ambient thermal resistance θ<sub>JA</sub>, and the ambient temperature T<sub>A</sub>. The maximum allowable continuous power dissipation at any ambient temperature is calculated by P<sub>D</sub> (MAX) = (T<sub>J</sub> (MAX)-T<sub>A</sub>)/θ<sub>JA</sub>. Exceeding the maximum allowable power dissipation produces an excessive die temperature, causing the regulator to go into thermal shutdown. Internal thermal shutdown circuitry protects the device from permanent damage.
- 3) The device is not guaranteed to function outside of its operating conditions.
- 4) Measured on JESD51-7, 4-layer PCB.

## ELECTRICAL CHARACTERISTICS

$V_{IN} = 3.6V$ ,  $T_J = -40^{\circ}C$  to  $+125^{\circ}C$ , typical value is tested at  $T_J = +25^{\circ}C$ . The limit over temperature is guaranteed by characterization, unless otherwise noted.

Parameter	Symbol	Condition	Min	Typ	Max	Units
Feedback voltage (MPM3804GG only)	$V_{FB}$	$2.3V \leq V_{IN} \leq 5.5V$ , $T_J = 25^{\circ}C$	0.594	0.600	0.606	V
		$2.3V \leq V_{IN} \leq 5.5V$	0.591	0.600	0.609	
Fixed Output Voltage	$V_{OUT\_1.2}$	Only for MPM3804GG-12, $I_{OUT}=10mA, T_J=+25^{\circ}C$	1.188	1.2	1.212	V
	$V_{OUT\_1.2}$	Only for MPM3804GG-12, $I_{OUT}=10mA, T_J=-40^{\circ}C$ to $+125^{\circ}C$	1.176	1.2	1.224	V
	$V_{OUT\_1.8}$	Only for MPM3804GG-18, $I_{OUT}=10mA, T_J=+25^{\circ}C$	1.782	1.8	1.818	V
	$V_{OUT\_1.8}$	Only for MPM3804GG-18, $I_{OUT}=10mA, T_J=-40^{\circ}C$ to $+125^{\circ}C$	1.764	1.8	1.836	V
	$V_{OUT\_2.5}$	Only for MPM3804GG-25, $I_{OUT}=10mA, T_J=+25^{\circ}C$	2.475	2.5	2.525	V
	$V_{OUT\_2.5}$	Only for MPM3804GG-25, $I_{OUT}=10mA, T_J=-40^{\circ}C$ to $+125^{\circ}C$	2.45	2.5	2.55	V
	$V_{OUT\_3.3}$	Only for MPM3804GG-33, $I_{OUT}=10mA, T_J=+25^{\circ}C$	3.267	3.3	3.333	V
	$V_{OUT\_3.3}$	Only for MPM3804GG-33, $I_{OUT}=10mA, T_J=-40^{\circ}C$ to $+125^{\circ}C$	3.234	3.3	3.366	V
Feedback current (MPM3804GG only)	$I_{FB}$	$V_{FB} = 0.65V$		50	100	nA
P-FET switch on resistance (MPM3804GG only)	$R_{DSON\_P}$			120		m $\Omega$
N-FET switch on resistance (MPM3804GG only)	$R_{DSON\_N}$			80		m $\Omega$
P-FET switch on resistance (MPM3804GG-XX only)	$R_{DSON\_P\_F}$			130		m $\Omega$
N-FET switch on resistance (MPM3804GG-XX only)	$R_{DSON\_N\_F}$			100		m $\Omega$
Switch leakage		$V_{EN} = 0V, V_{IN} = 6V$ , $V_{SW} = 0V, T_J = 25^{\circ}C$		0	1	$\mu A$
P-FET peak current limit (MPM3804GG only)			1	1.3	1.6	A
N-FET valley current limit (MPM3804GG only)				0.4		A
P-FET peak current limit (MPM3804GG-XX only)			0.9	1.3	1.6	A
N-FET valley current limit (MPM3804GG-XX only)				0.5		A

### ELECTRICAL CHARACTERISTICS (continued)

$V_{IN} = 3.6V$ ,  $T_J = -40^{\circ}C$  to  $+125^{\circ}C$ , typical value is tested at  $T_J = +25^{\circ}C$ . The limit over temperature is guaranteed by characterization, unless otherwise noted.

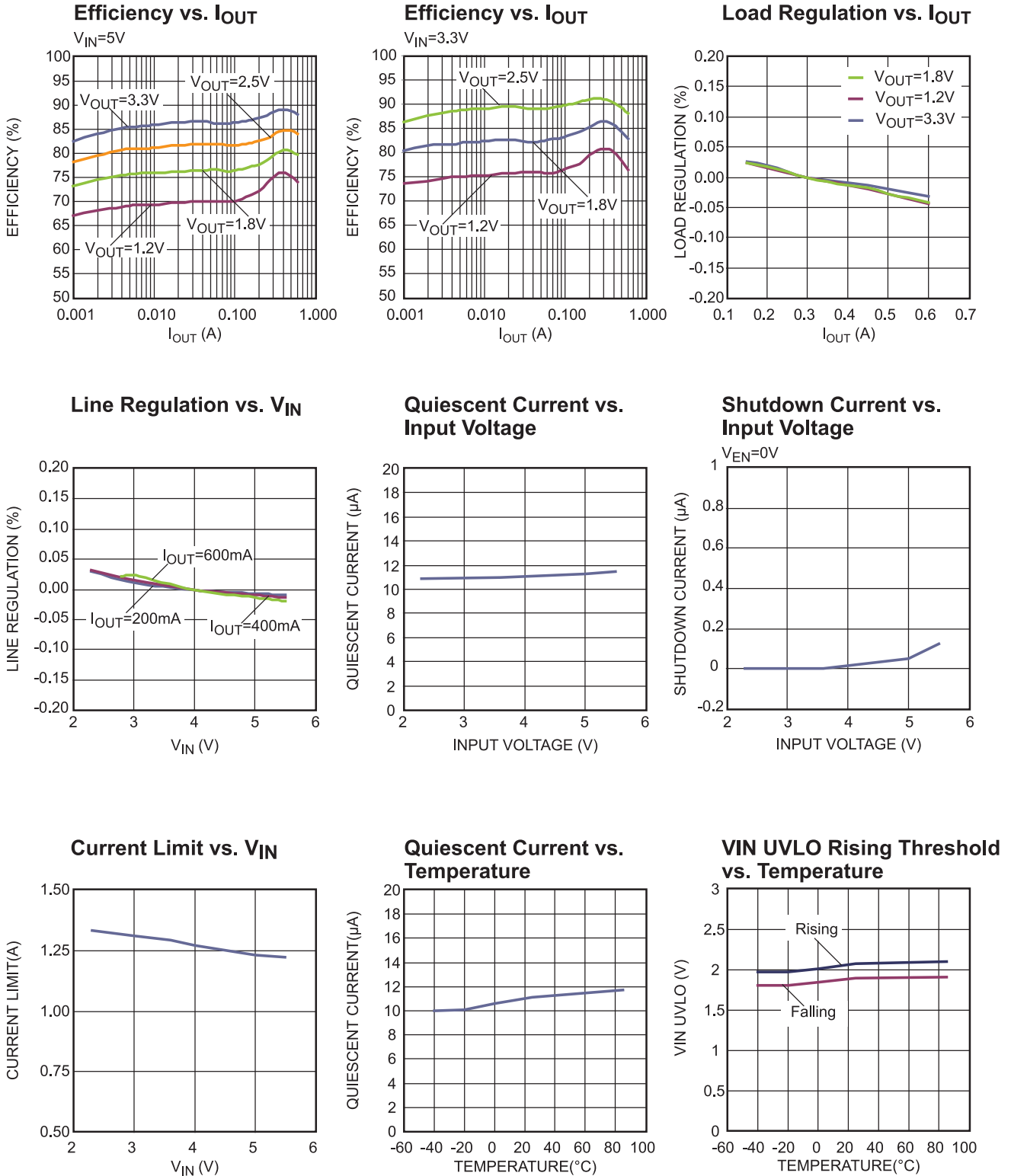
Parameter	Symbol	Condition	Min	Typ	Max	Units
Switching frequency	$f_s$	$V_{OUT} = 1.2V$	1920	2400	2910	kHz
		$T_J = -40^{\circ}C$ to $+85^{\circ}C^{(6)}$	1800	2400	3000	kHz
Minimum off time	$T_{MIN-OFF}$			60		ns
Minimum on time <sup>(5)</sup>	$T_{MIN-ON}$			60		ns
Soft-start time	$T_{SS-ON}$			0.5		ms
Under-voltage lockout threshold rising (MPM3804GG only)				2	2.25	V
Under-voltage lockout threshold rising (MPM3804GG-XX only)				2	2.3	V
Under-voltage lockout threshold hysteresis				150		mV
EN input logic-low voltage					0.4	V
EN input logic-high voltage			1.2			V
EN input current		$V_{EN} = 2V$		1.2		$\mu A$
		$V_{EN} = 0V$		0		$\mu A$
Supply current (shutdown)		$V_{EN} = 0V$ , $T_J = 25^{\circ}C$		0	1	$\mu A$
Supply current (quiescent) (MPM3804GG only)		$V_{EN} = 2V$ , $V_{IN} = 3.6V, 5V$ , $V_{FB} = 0.63V$ , $T_J = 25^{\circ}C$		11	15	$\mu A$
Supply current (quiescent) (MPM3804GG-XX only)		$V_{IN} = 3.6V$ , $V_{EN} = 2V$ , $V_{FB} = 0.63V$ , no switching, $T_J = 25^{\circ}C$		340	400	$\mu A$
Power Good Leakage Current (MPM3804GG-XX only)	$I_{PG}$			50	100	nA
Power Good Upper Trip Threshold <sup>(6)</sup> (MPM3804GG-XX only)		$V_o$ with Respect to Regulation		90		%
Power Good Lower Trip Threshold <sup>(6)</sup> (MPM3804GG-XX only)				83		%
Power Good Sink Current Capability (MPM3804GG-XX only)		Sink 1mA			400	mV
Thermal shutdown <sup>(6)</sup>				160		$^{\circ}C$
Thermal hysteresis <sup>(6)</sup>				30		$^{\circ}C$
Output discharge resistor	$R_{DIS}$	$V_{EN} = 0V$ , $V_{OUT} = 1.2V$		1		k $\Omega$
Output inductor	L	Test frequency = 1MHz		1		$\mu H$
	DCR	$T_J = 25^{\circ}C$			0.4	$\Omega$

**NOTES:**

- 5) Guaranteed by characterization.  
6) Guaranteed by design.

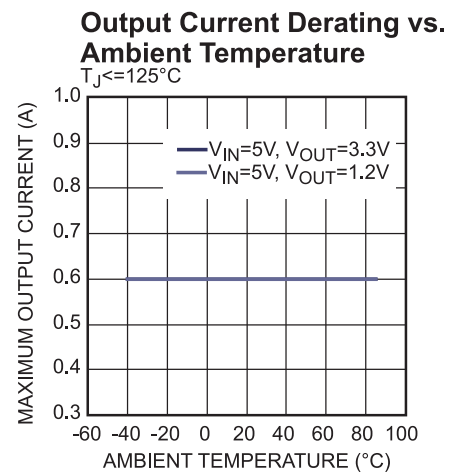
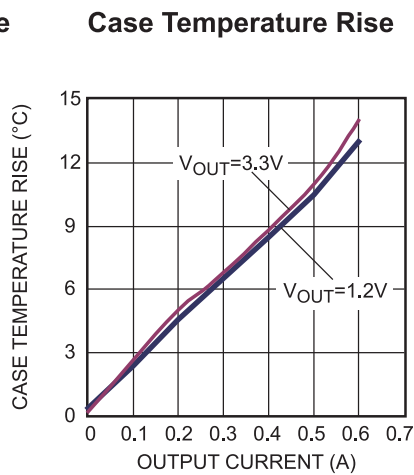
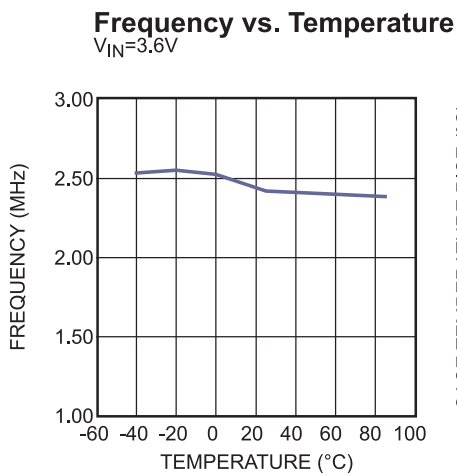
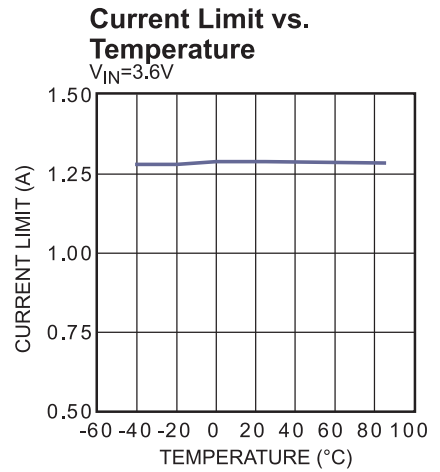
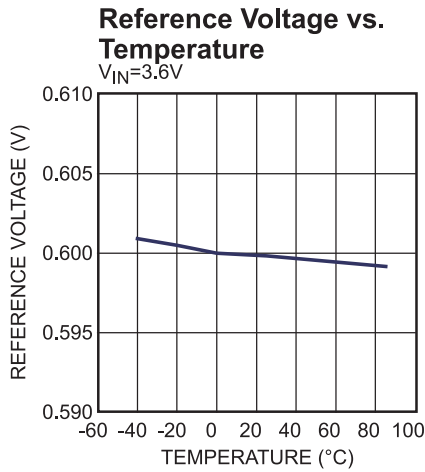
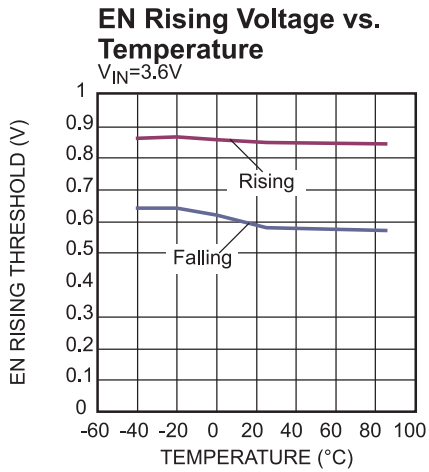
**TYPICAL PERFORMANCE CHARACTERISTICS**

$V_{IN} = 5V$ ,  $V_{OUT} = 1.2V$ ,  $C_{OUT} = 22\mu F$ ,  $T_A = +25^\circ C$ , unless otherwise noted.



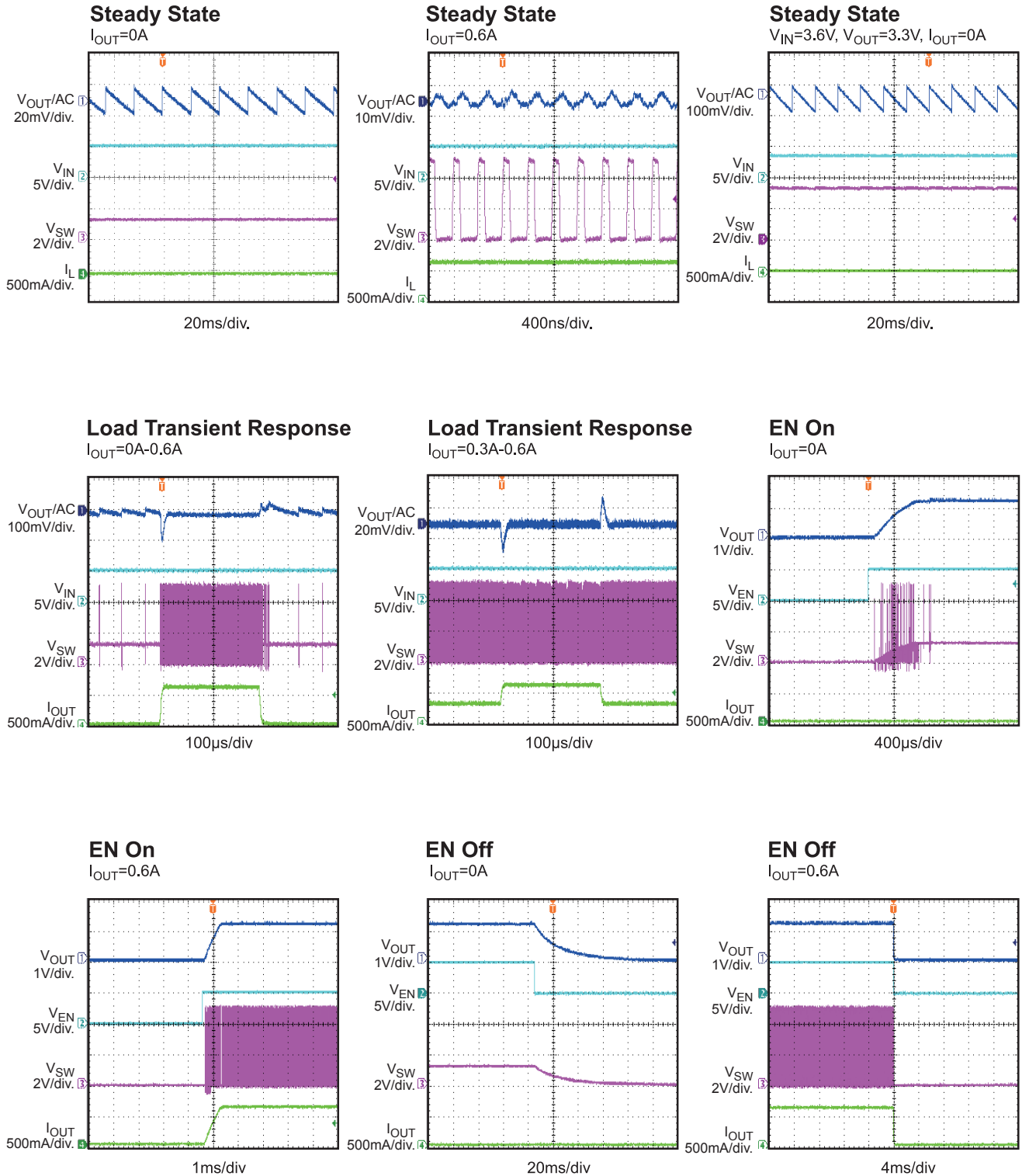
**TYPICAL PERFORMANCE CHARACTERISTICS (continued)**

$V_{IN} = 5V$ ,  $V_{OUT} = 1.2V$ ,  $C_{OUT} = 22\mu F$ ,  $T_A = +25^\circ C$ , unless otherwise noted.



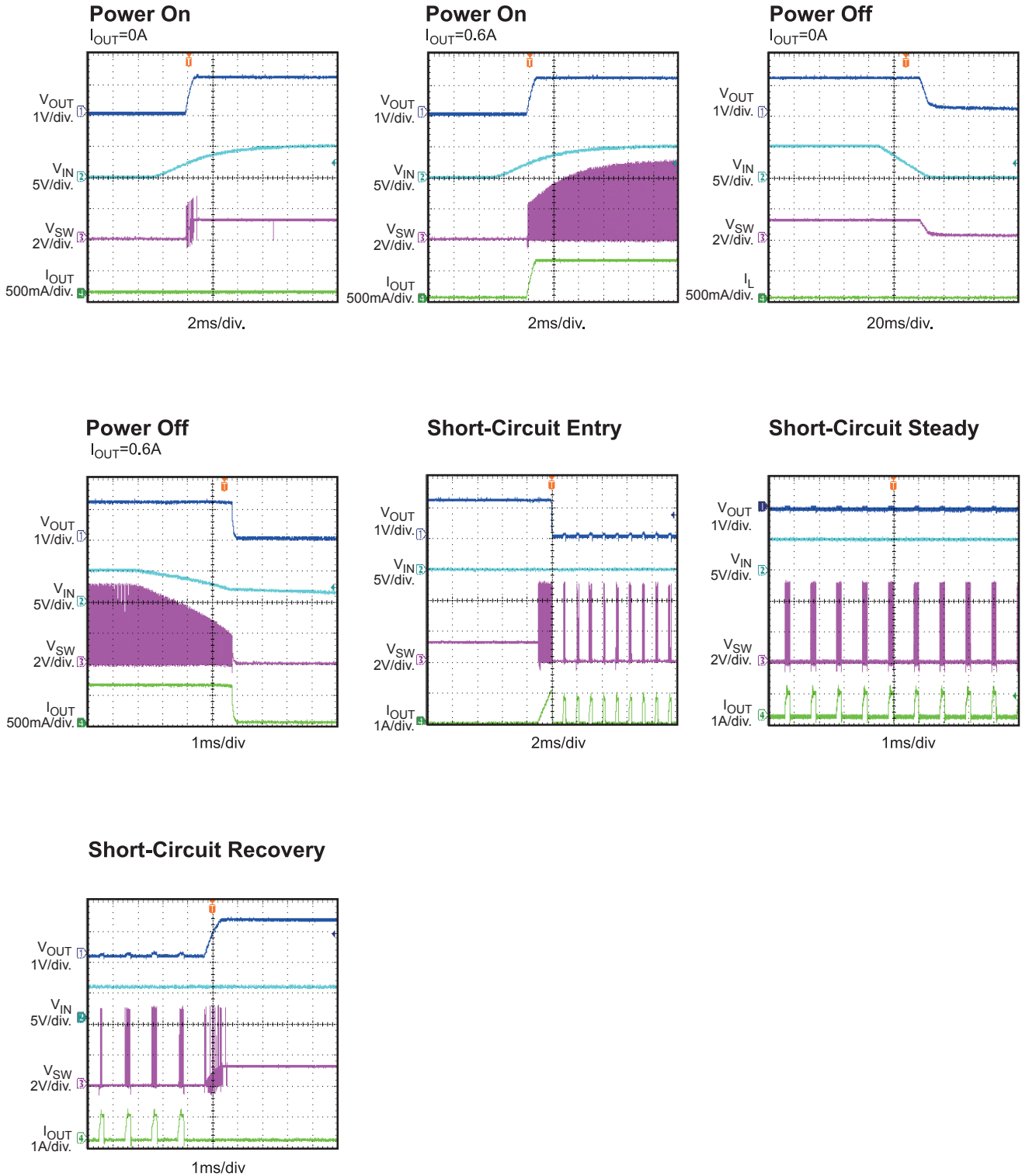
**TYPICAL PERFORMANCE CHARACTERISTICS (continued)**

$V_{IN} = 5V$ ,  $V_{OUT} = 1.2V$ ,  $C_{OUT} = 22\mu F$ ,  $T_A = +25^\circ C$ , unless otherwise noted.



**TYPICAL PERFORMANCE CHARACTERISTICS (continued)**

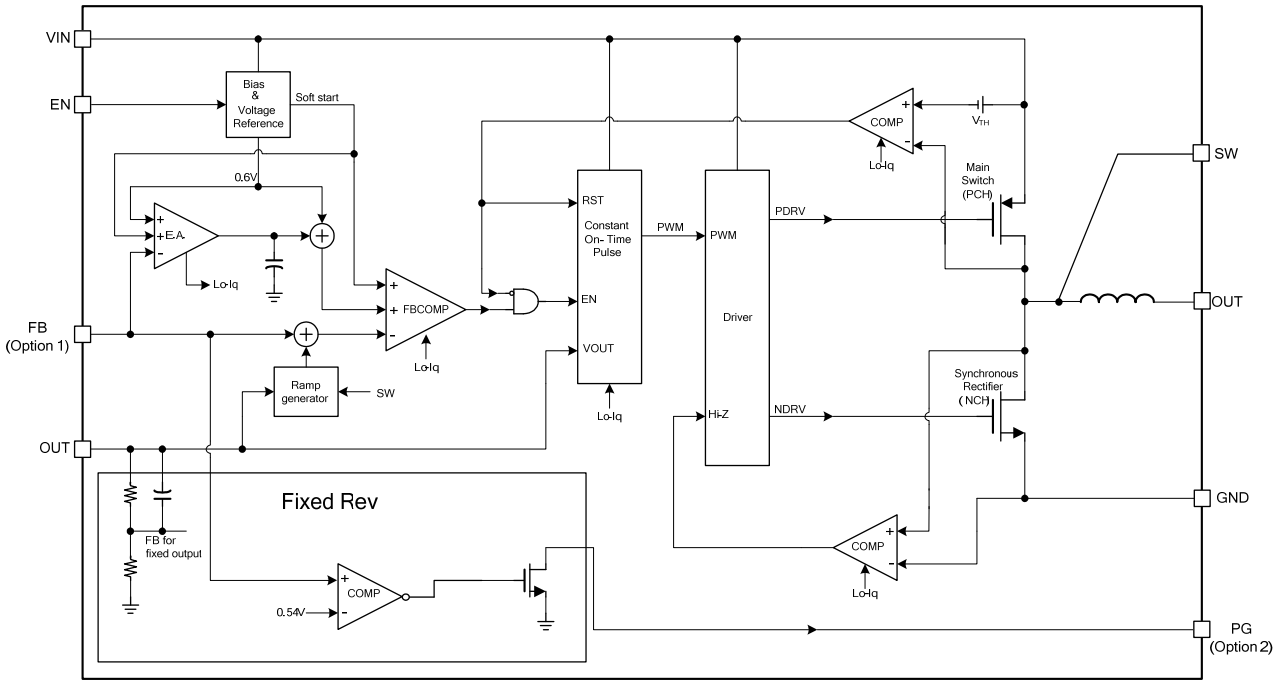
$V_{IN} = 5V$ ,  $V_{OUT} = 1.2V$ ,  $C_{OUT} = 22\mu F$ ,  $T_A = +25^\circ C$ , unless otherwise noted.



## PIN FUNCTIONS

Pin #	Name	Description
1	VIN	<b>Supply voltage.</b> The MPM3804 operates from a +2.3V to +5.5V unregulated input. A decoupling capacitor is needed to prevent large voltage spikes from appearing at the input.
2, 3, 4	SW	<b>Output switching node.</b> SW is the drain of the internal, high-side, P-channel MOSFET. SW is not for testing and is for internal use only.
5	EN	<b>On/off control.</b>
6, 7, 8	OUT	<b>Output voltage power rail and output voltage input sense.</b> Connect the load to OUT. An output capacitor is needed to decrease the output voltage ripple.
9	FB/PG	<b>MPM3804GG: Feedback.</b> An external resistor divider from the output to GND tapped to FB sets the output voltage. <b>MPM3804GG-XX: Power good indicator.</b> The output of PG is an open-drain output.
10	GND	<b>Power ground.</b>

**BLOCK DIAGRAM**



**Figure 1: Functional Block Diagram**

**NOTE:** FB is only for the MPM3804GG (option 1); PG is only for the MPM3804GG-XX (option 2).

## OPERATION

The MPM3804 uses a constant-on-time (COT) control with input voltage feed-forward to stabilize the switching frequency over the full input range. The MPM3804 achieves 0.6A of continuous output current from a 2.3V to 5.5V input voltage range with excellent load and line regulation. The output voltage can be regulated as low as 0.6V.

### Constant-On-Time (COT) Control

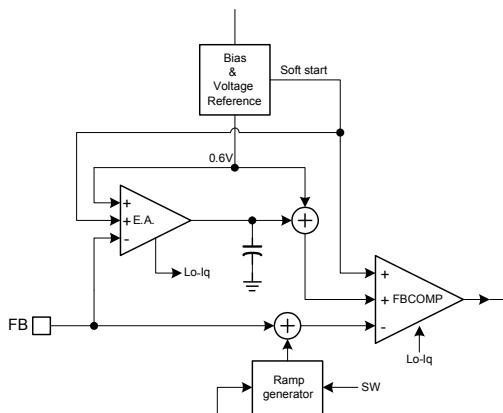
Compared to fixed-frequency PWM control, constant-on-time (COT) control offers a simpler control loop and faster transient response. By using an input voltage feed-forward, the MPM3804 maintains a nearly constant switching frequency across the input and output voltage ranges. The switching pulse on time can be estimated with Equation (1):

$$T_{ON} = \frac{V_{OUT}}{V_{IN}} \cdot 0.417\mu s \quad (1)$$

To prevent inductor current runaway during the load transient, the MPM3804 has a fixed minimum off time of 60ns. This minimum off time limit will not affect operation in steady state in any way.

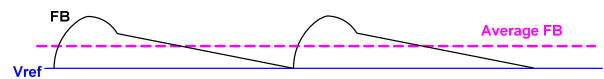
### Sleep-Mode Operation

The MPM3804 uses sleep mode to achieve high efficiency at extremely light loads. In sleep mode, most of the circuit blocks are turned off except for the error amplifier and PWM comparator. Therefore, the operation current is reduced to a minimal value (see Figure 2).



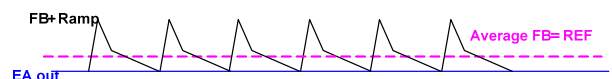
**Figure 2: Operation Blocks at Sleep Mode**

When the loading becomes lighter, the ripple of the output voltage is bigger and drives the error amplifier output (EAO) lower. When the EAO reaches the internal low threshold, it is clamped at that level, and the MPM3804 enters sleep mode. During sleep mode, the valley of the FB voltage is regulated to the internal reference voltage, and the average output voltage is slightly higher than the output voltage in discontinuous conduction mode (DCM) or continuous conduction mode (CCM). The on-time pulse in sleep mode is around 40% larger than that in DCM or CCM. Figure 3 shows the average FB voltage relationship with the internal reference in sleep mode.



**Figure 3: FB Average Voltage in Sleep Mode**

When the MPM3804 is in sleep mode, the average output voltage is higher than the internal reference voltage. The EAO is kept low and clamped in sleep mode. When the load increases, the PWM switching period decreases to keep the output voltage regulated, and the output voltage ripple decreases relatively. Once the EAO is higher than the internal low threshold, the MPM3804 exits sleep mode and enters DCM or CCM depending on the load. In DCM or CCM, the error amplifier regulates the average output voltage to the internal reference (see Figure 4).

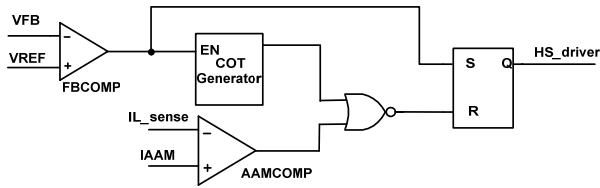


**Figure 4: DCM Control**

There is always a loading hysteresis when entering and exiting sleep mode due to the error amplifier clamping response time.

### AAM Operation at Light-Load Operation

The MPM3804 uses advanced asynchronous modulation (AAM) power-save mode together with a zero-current cross detection (ZCD) circuit for light load. The MPM3804 has AAM power-save mode for light load. Figure 5 shows the simplified AAM control theory. The AAM current ( $I_{AAM}$ ) is set internally. In light-load condition, the SW on pulse time is determined by the on-time generator and AAM comparator.



**Figure 5: Simplified AAM Control Logic**

The MPM3804 uses a ZCD to determine when the inductor current starts to reverse. When the inductor current reaches the ZCD threshold, the low-side switch is turned off.

AAM mode together with the ZCD circuit makes the MPM3804 work in DCM at light load continuously, even if  $V_{OUT}$  is close to  $V_{IN}$ .

### Enable (EN)

When the input voltage is greater than the under-voltage lockout (UVLO) threshold (typically 2V), the MPM3804 can be enabled by pulling EN higher than 1.2V. Leave EN floating or pull EN down to ground to disable the MPM3804. There is an internal 1M $\Omega$  resistor from EN to ground.

When the device is disabled, the part goes into output discharge mode automatically. The internal discharge MOSFET provides a resistive discharge path for the output capacitor.

### Soft Start (SS)

The MPM3804 has a built-in soft start (SS) that ramps up the output voltage at a controlled slew rate to avoid overshooting at start-up. The soft-start time is about 0.5ms for  $V_{OUT}$  rising from 10% to 90% typically.

### Power Good Indicator (only for MPM3804GG-XX)

The MPM3804 has an open drain and requires an external pull-up resistor (100k $\Omega$ ~500k $\Omega$ ) for the power good (PG) indicator. When  $V_{FB}$  is within -10% of regulation voltage,  $V_{PG}$  is pulled up to  $V_{IN}$  by the external resistor. If  $V_{FB}$  exceeds the -10% window, the internal MOSFET pulls PG to ground. The MOSFET has a maximum  $R_{DS(ON)}$  of less than 100 $\Omega$ .

### Current Limit

The MPM3804 has a 1.3A, high-side, switch-current limit, typically. When the high-side switch reaches its current limit, the MPM3804 remains in hiccup mode until the current drops. This prevents the inductor current from continuing to rise and damaging components.

### Short Circuit and Recovery

The MPM3804 enters short-circuit protection (SCP) mode when it reaches the current limit and attempts to recover with hiccup mode. The MPM3804 disables the output power stage, discharges the soft-start capacitor, and attempts to soft start automatically. If the short-circuit condition remains after the soft start ends, the MPM3804 repeats this cycle until the short circuit is removed and the output rises back to regulation levels.

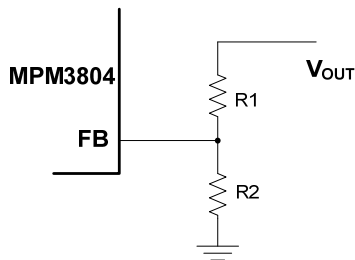
## APPLICATION INFORMATION

### Setting the Output Voltage (only for MPM3804GG)

The external resistor divider sets the output voltage (see the Typical Application Circuits on page 15). Select the feedback resistor (R1) to reduce the  $V_{OUT}$  leakage current, typically between 40kΩ to 200kΩ. There is no strict requirement on the feedback resistor. R1 > 10kΩ is reasonable for most applications. R2 can be calculated with Equation (2):

$$R2 = \frac{R1}{\frac{V_{out}}{0.6} - 1} \quad (2)$$

Figure 6 shows the feedback circuit.



**Figure 6: Feedback Network**

Table 1 lists the recommended resistor values for common output voltages.

**Table 1: Resistor Values for Common Output Voltages**

$V_{OUT}$ (V)	R1 (kΩ)	R2 (kΩ)
1.0	200 (1%)	300 (1%)
1.2	200 (1%)	200 (1%)
1.8	200 (1%)	100 (1%)
2.5	200 (1%)	63.2 (1%)
3.3	200 (1%)	44.2 (1%)

### Selecting the Input Capacitor

The input current to the step-down converter is discontinuous and therefore requires a capacitor to supply AC current to the step-down converter while maintaining the DC input voltage. Use low ESR capacitors for the best performance. Ceramic capacitors with X5R or X7R dielectrics are highly recommended because of their low ESR and small temperature coefficients. Typically, a 10μF input capacitor is sufficient for most applications.

The input capacitor requires an adequate ripple current rating since it absorbs the input switching current. Estimate the RMS current in the input capacitor with Equation (3):

$$I_{C1} = I_{LOAD} \times \sqrt{\frac{V_{OUT}}{V_{IN}} \times \left(1 - \frac{V_{OUT}}{V_{IN}}\right)} \quad (3)$$

The worst-case scenario occurs at  $V_{IN} = 2V_{OUT}$ , shown in Equation (4):

$$I_{C1} = \frac{I_{LOAD}}{2} \quad (4)$$

For simplification, choose an input capacitor with an RMS current rating greater than half of the maximum load current.

The input capacitor can be electrolytic, tantalum, or ceramic. When using electrolytic or tantalum capacitors, add a small, high-quality, 0.1μF, ceramic capacitor as close to the IC as possible. When using ceramic capacitors, ensure that they have enough capacitance to provide a sufficient charge to prevent excessive voltage ripple at the input. The input voltage ripple caused by the capacitance can be estimated with Equation (5):

$$\Delta V_{IN} = \frac{I_{LOAD}}{f_s \times C1} \times \frac{V_{OUT}}{V_{IN}} \times \left(1 - \frac{V_{OUT}}{V_{IN}}\right) \quad (5)$$

### Selecting the Output Capacitor

The output capacitor (C2) stabilizes the DC output voltage. Low ESR ceramic capacitors are recommended to limit the output voltage ripple. Estimate the output voltage ripple with Equation (6):

$$\Delta V_{OUT} = \frac{V_{OUT}}{f_s \times L_1} \times \left(1 - \frac{V_{OUT}}{V_{IN}}\right) \times \left(R_{ESR} + \frac{1}{8 \times f_s \times C2}\right) \quad (6)$$

Where  $L_1$  is the inductor value, and  $R_{ESR}$  is the equivalent series resistance (ESR) value of the output capacitor. The MPM3804 has an internal, co-packaged, 1μH power inductor.

When using ceramic capacitors, the capacitance dominates the impedance at the switching frequency and causes most of the output voltage ripple. For simplification, the output voltage ripple can be estimated with Equation (7):

$$\Delta V_{OUT} = \frac{V_{OUT}}{8 \times f_s^2 \times L_1 \times C2} \times \left(1 - \frac{V_{OUT}}{V_{IN}}\right) \quad (7)$$

For tantalum or electrolytic capacitors, the ESR dominates the impedance at the switching frequency. For simplification, the output ripple can be approximated with Equation (8):

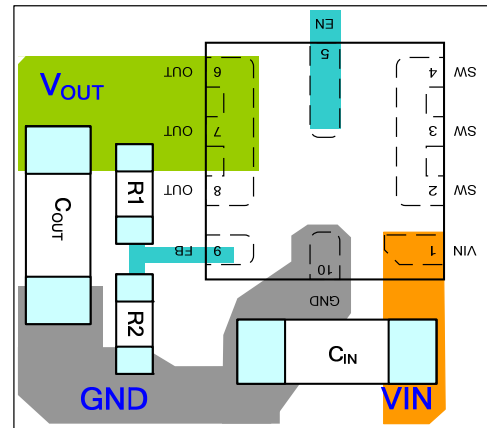
$$\Delta V_{OUT} = \frac{V_{OUT}}{f_s \times L_1} \times \left(1 - \frac{V_{OUT}}{V_{IN}}\right) \times R_{ESR} \quad (8)$$

The characteristics of the output capacitor also affect the stability of the regulation system. Typically, a 10µF output capacitor is sufficient to meet most applications. Add a 22µF output capacitor to achieve a low output voltage ripple.

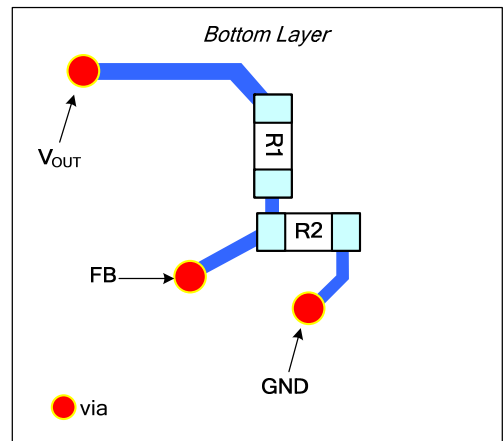
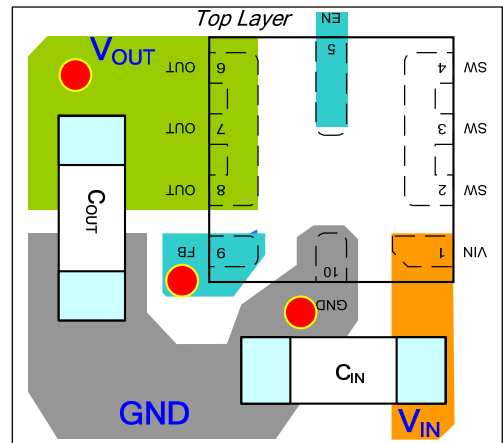
### PCB Layout Guidelines

Efficient PCB layout of the switching power supplies is critical for stable operation. For the high-frequency switching converter, a poor layout design can result in poor line or load regulation and stability issues. For best results, refer to Figure 7 and Figure 8 and follow the guidelines below.

1. Place the high-current paths (GND and IN) very close to the device with short, direct, and wide traces.
2. Place the input capacitor as close to IN and GND as possible.
3. Place the external feedback resistors next to FB (only for the MPM3804GG).

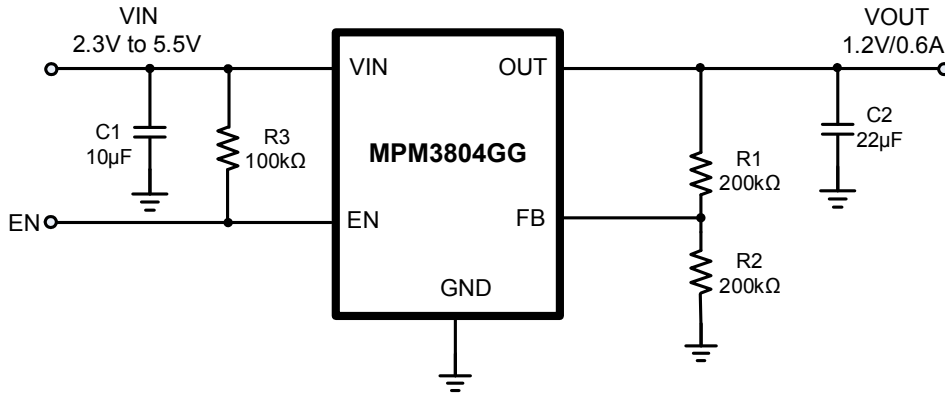


**Figure 7: Single-Layer PCB Layout**

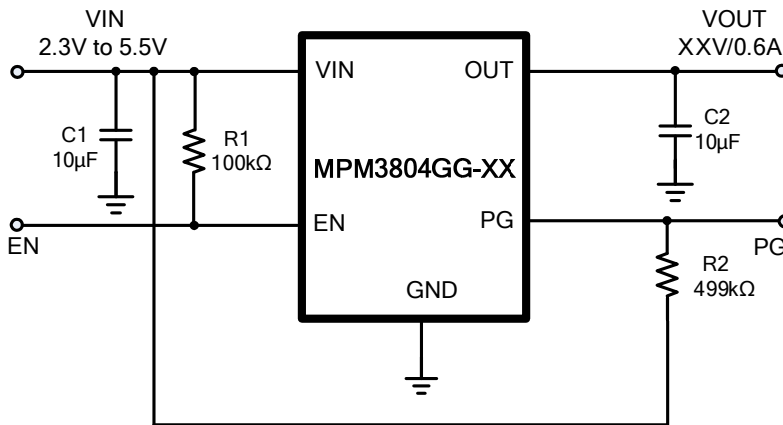


**Figure 8: Double-Layer PCB Layout**

**TYPICAL APPLICATION CIRCUITS**



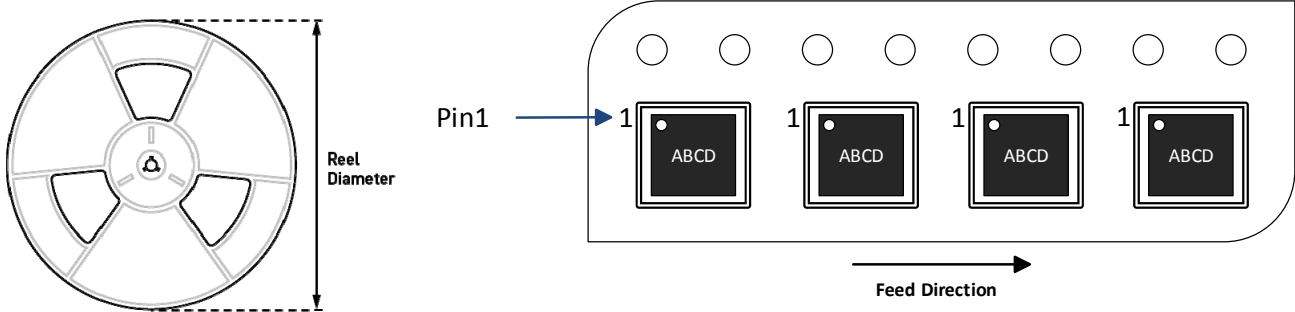
**Figure 9: Typical Application Circuit for MPM3804GG**



**Figure 10: Typical Application Circuit for MPM3804GG-XX**  
**NOTE:  $V_{IN} > V_{OUT}$  for application.**



**CARRIER INFORMATION**



Part Number	Package Description	Quantity/ Reel	Quantity/ Tube	Quantity/ Tray	Reel Diameter	Carrier Tape Width	Carrier Tape Pitch
MPM3804GG-Z	QFN 2x2	5000	N/A	N/A	13in	12mm	8mm
MPM3804GG-12-Z							
MPM3804GG-18-Z							
MPM3804GG-25-Z							
MPM3804GG-33-Z							

## Revision History

Revision #	Revision Date	Description	Pages Updated
1.0	05/03/2018	Initial Release	-
1.1	06/05/2020	Added ESD, MSL, and carrier information	2, 3, 18
		Deleted MPM3804GG-15	2
		Updated EC table	4, 5
		Added MPM3804GG-xx TOP marking information	2

**NOTICE:** The information in this document is subject to change without notice. Users should warrant and guarantee that third party Intellectual Property rights are not infringed upon when integrating MPS products into any application. MPS will not assume any legal responsibility for any said applications.

# Mouser Electronics

Authorized Distributor

Click to View Pricing, Inventory, Delivery & Lifecycle Information:

[Monolithic Power Systems \(MPS\):](#)

[MPM3804GG-25-P](#) [MPM3804GG-25-Z](#)