



# CT100

## 1D Linear Sensor

### Features

- Operating Magnetic Field Range:  $\pm 20$  mT
- Stable Magnetic Performance over Temperature
- Linearity Error:  $\pm 0.5\%$
- Differential Outputs
- Supply Voltage: 1.0 V to 5.5 V
- Operating Temperature:  $-40^{\circ}\text{C}$  to  $+150^{\circ}\text{C}$
- Package Options:
  - 6-lead SOT23
  - 6-lead DFN,  $1.50 \times 1.50 \times 0.45$  mm
  - KGD (Known Good Die) in Wafer Form

### Applications

- Linear Measurements
- Proximity Sensing
- Current Sensing

### Product Description

The CT100 is a 1D linear sensor in full-bridge configuration from Crocus Technology developed on its patented MLU™ technology. The magnetic field range for the CT100 is from  $-20$  mT to  $+20$  mT and achieves a linearity error of  $\pm 0.5\%$  while providing unparalleled temperature stability. It supports a wide operating voltage range of 1.0 V to 5.5 V.

It is available in a 6-lead SOT23 package and for space critical applications, a low profile and small form factor 6-lead DFN package that is  $1.50 \times 1.50 \times 0.45$  mm in size. The CT100 is also made available in die form where it will be shipped as unsawn wafers (wafer map files will be provided to indicate known good die).

## Ordering Information

Part Number	Operating Temperature Range	Output Type	Package	Packing Method
CT100LW-IS6	$-40^{\circ}\text{C}$ to $+85^{\circ}\text{C}$	Differential	6-lead SOT23 $2.90 \times 2.80 \times 1.20$ mm	Tape & Reel
CT100LW-HS6	$-40^{\circ}\text{C}$ to $+125^{\circ}\text{C}$			
CT100LW-FS6	$-40^{\circ}\text{C}$ to $+150^{\circ}\text{C}$			
CT100LW-ID6	$-40^{\circ}\text{C}$ to $+85^{\circ}\text{C}$	Differential	6-lead DFN $1.50 \times 1.50 \times 0.45$ mm	Tape & Reel
CT100LW-HD6	$-40^{\circ}\text{C}$ to $+125^{\circ}\text{C}$			
CT100LW-FD6	$-40^{\circ}\text{C}$ to $+150^{\circ}\text{C}$			
CT100LW-KGD	$-40^{\circ}\text{C}$ to $+150^{\circ}\text{C}$	Differential	Wafer Form	Unsawn Wafer

Block Diagram

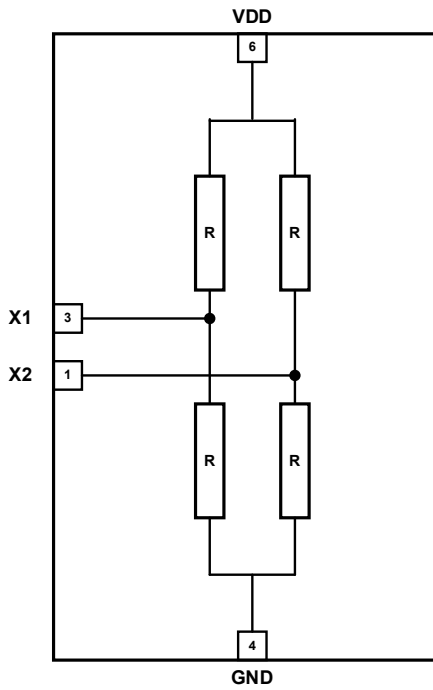

Figure 1. CT100 Functional Block Diagram for SOT23-6

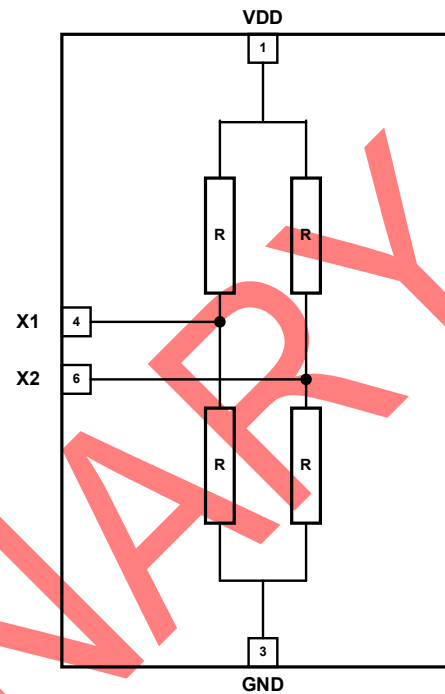

Figure 2. CT100 Functional Block Diagram for DFN-6

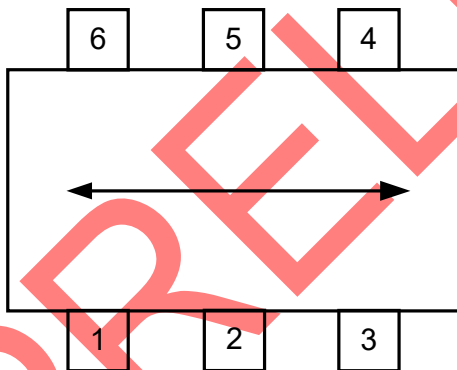

Figure 3. CT100 Axis of Sensitivity for SOT23-6 (Top Down View)

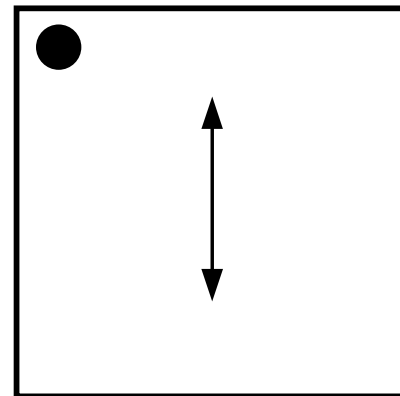

Figure 4. CT100 Axis of Sensitivity for DFN-6 (Top Down View)

Pin Configuration

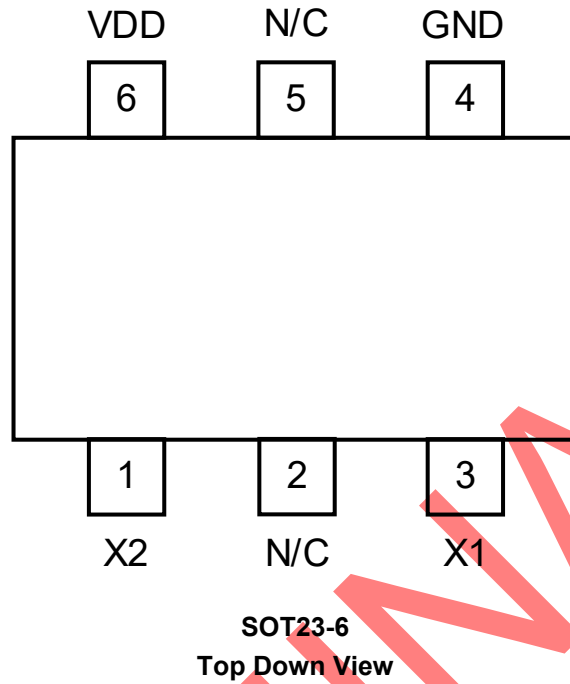
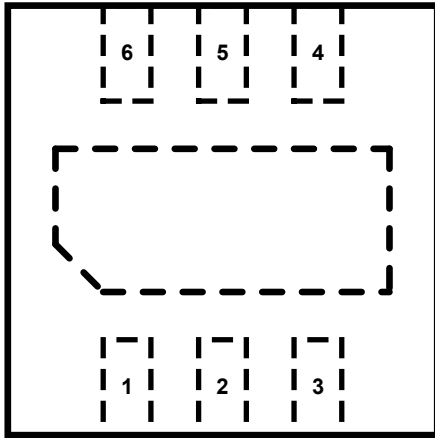

Figure 5. CT100 Pin-out Diagram

Pin Definitions

SOT23-6 Pin #	Pin Name	Pin Description
1	X2	Differential Output X2
2	N/C	No Connect
3	X1	Differential Output X1
4	GND	Ground
5	N/C	No Connect
6	VDD	Supply Voltage

Pin Configuration



DFN-6 – Top Down View

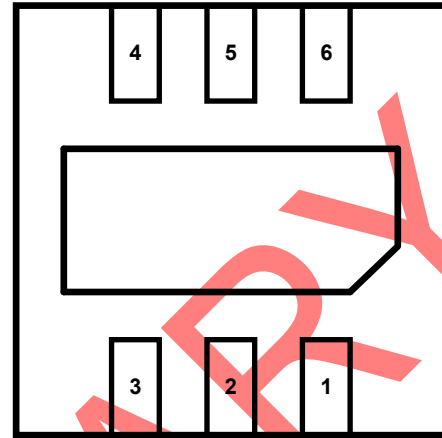

DFN-6 – Bottoms Up View

Figure 6. CT100 Pin-out Diagrams

Pin Definitions

DFN-6 Pin #	Pin Name	Pin Description
1	VDD	Supply Voltage
2	N/C	No Connect
3	GND	Ground
4	X1	Differential Output X1
5	N/C	No Connect
6	X2	Differential Output X2

Pad Configuration

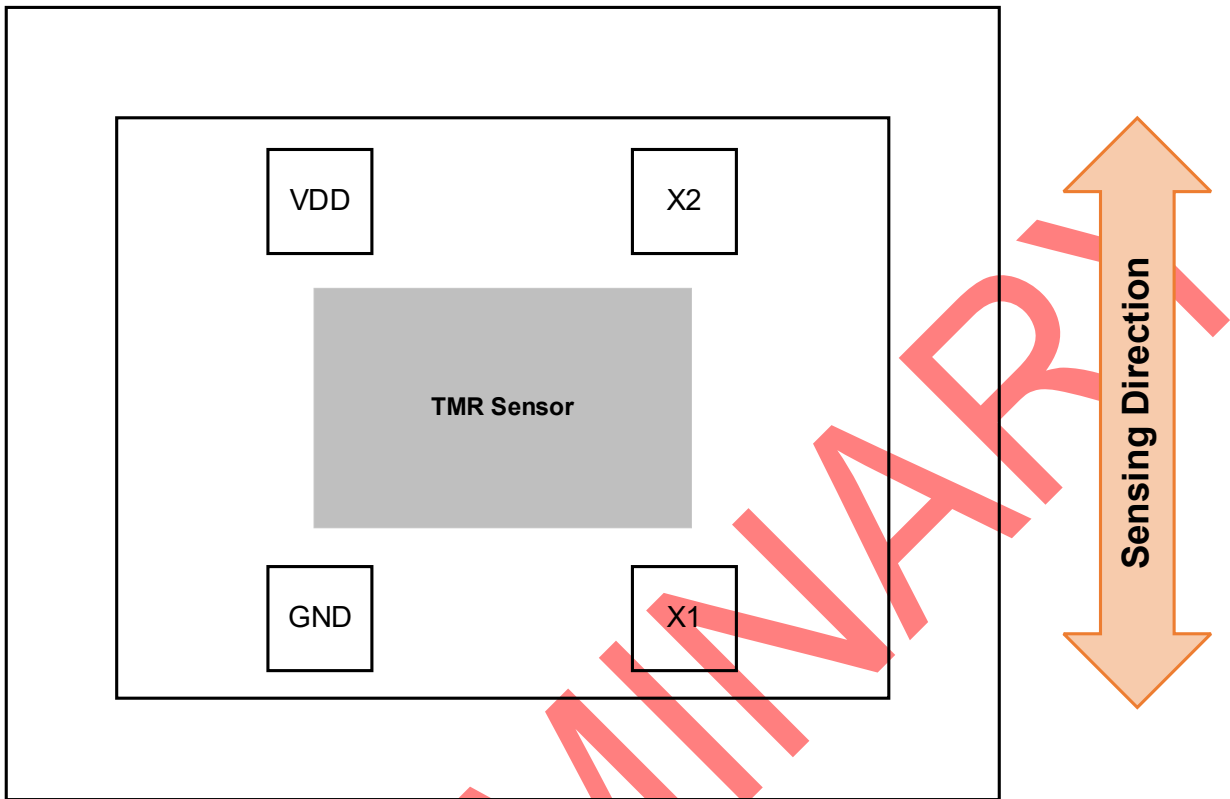

CT100 Die Layout and Axis of Sensitivity  
Top Down View

Figure 7. CT100 Pad Diagram

Pad Definitions

Pad #	Pad Name	Pad Description
1	VDD	Supply Voltage
2	X2	Differential Output X2
3	X1	Differential Output X1
4	GND	Ground

## Absolute Maximum Ratings

Stresses exceeding the absolute maximum ratings may damage the CT100 and may not function or be operable above the recommended operating conditions and stressing the parts to these levels is not recommended. In addition, extended exposure to stresses above the recommended operating conditions may affect device reliability. The absolute maximum ratings are stress ratings only.

Symbol	Parameter	Min.	Max.	Unit
V <sub>DD</sub>	Supply Voltage	-0.3	6.0	V
V <sub>OUT</sub>	Analog Output Pins Maximum Voltage	-660	+660	mV
ESD	Electrostatic Discharge Protection Level	Human Body Model (HBM) per JESD22-A114	±4.0	kV
		Charged Device Model (CDM) per JESD22-C101	±1.0	
B <sub>MAX</sub>	Maximum Magnetic Field, ≤ 5 minutes		±200	mT
B <sub>SHIFT</sub>	Life-time Shift due to B <sub>MAX</sub> Field Exposure		±1	mT
T <sub>STG</sub>	Storage Temperature	-65	+160	°C
T <sub>L</sub>	Lead Soldering Temperature, 10 Seconds		+260	°C

## Recommended Operating Conditions

The Recommended Operating Conditions table defines the conditions for actual operation of the CT100. Recommended operating conditions are specified to ensure optimal performance to the specifications. Crocus Technology does not recommend exceeding them or designing to absolute maximum ratings.

Symbol	Parameter	Min.	Typ.	Max.	Unit	
V <sub>DD</sub>	Supply Voltage Range	1.0	3.0	5.5	V	
V <sub>OUT</sub>	OUT Voltage Range	-605		+605	mV	
B <sub>OPERATING</sub>	Operating Magnetic Field			±20	mT	
T <sub>A</sub>	Operating Ambient Temperature	Industrial	-40	+25	+85	°C
		Extended Industrial	-40	+25	+125	
		Full Range	-40	+25	+150	

## Thermal Properties

Junction-to-ambient thermal resistance is a function of application and board layout and is determined in accordance to JEDEC standard JESD51-7 for a four (4) layer 2s2p FR-4 printed circuit board (PCB) with 2 oz. of copper (Cu). Special attention must be paid not to exceed junction temperature T<sub>J(MAX)</sub> at a given ambient temperature T<sub>A</sub>.

Symbol	Parameter	Min.	Typ.	Max.	Unit
θ <sub>JA_SOT23</sub>	Junction-to-Ambient Thermal Resistance, SOT23-6		202		°C/W
θ <sub>JA_DFN6</sub>	Junction-to-Ambient Thermal Resistance, DFN-6		165		°C/W

## Electrical & Magnetic Specifications

Unless otherwise specified:  $V_{DD} = 1.0\text{ V to }5.5\text{ V}$  and  $T_A = -40^\circ\text{C to }+150^\circ\text{C}$ . Typical values are  $V_{DD} = 3.0\text{ V}$  and  $T_A = +25^\circ\text{C}$ .

Symbol	Parameter	Conditions	Min.	Typ.	Max.	Units
<b>Magnetic</b>						
$B_{OPERATING}$	Operating Magnetic Field <sup>(2)</sup>				$\pm 20$	mT
<b>Electrical</b>						
$R_{BRIDGE}$	Bridge Resistance		20		40	k $\Omega$
$P_D$	Power Consumption	$V_{DD} = 3.0\text{ V}$ , $R_{BRIDGE} = 30\text{ k}\Omega$		0.45		mW
$V_{OFFSET}$	Offset Voltage		-5		+5	mV/V
S	Sensitivity (Full-bridge Gain)	$B_{OPERATING} = \pm 20\text{ mT}$	3.5	4.0	4.5	mV/V/mT
$TCR_{BRIDGE}$	Temperature Coefficient Resistance of Bridge <sup>(1)</sup>				600	ppm/ $^\circ\text{C}$
TCO	Temperature Coefficient of Offset Voltage <sup>(1)</sup>				3.0	$\mu\text{V/V}/^\circ\text{C}$
TCS	Temperature Coefficient of Sensitivity <sup>(1)</sup>			-300	-350	ppm/ $^\circ\text{C}$
L	Linearity <sup>(1)</sup>	$B_{OP} = \pm 20\text{ mT}$			$\pm 0.5$	%
$E_{HYST}$	Hysteresis Error	$B_{OP} = \pm 20\text{ mT}$			0.05	%
$e_N$	Output Noise <sup>(1)</sup>	$f = 10\text{ Hz}$ , $V_{DD} = 3.0\text{ V}$ , $B_{OPERATING} = 10\text{ mT}$			2.0	$\mu\text{V}_{RMS}$

- (1) Guaranteed by design and characterization.
- (2) Wider operating magnetic field range available upon request.

## Electrical Characteristics

$V_{DD} = 3.0\text{ V}$  and  $T_A = +25^\circ\text{C}$ .

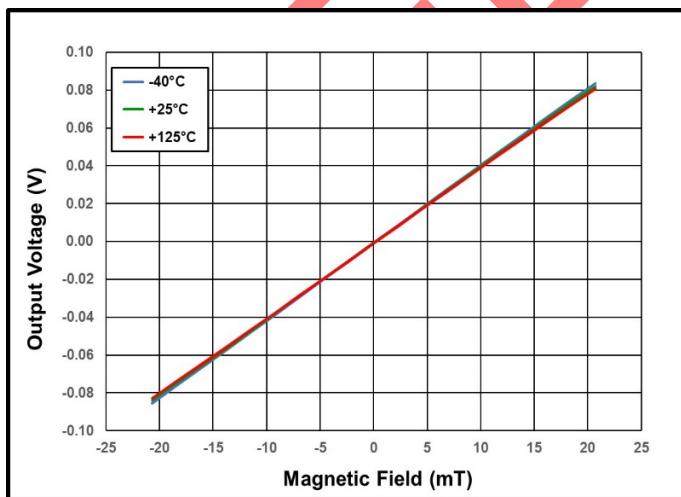

Figure 8. Sensitivity: Output Voltage vs. Magnetic Field vs. Temperature

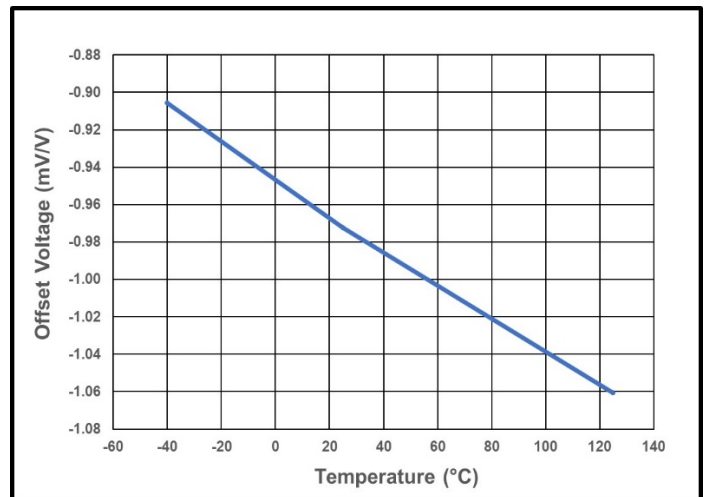

Figure 9. Offset Voltage vs. Temperature

Recommended Application Circuit

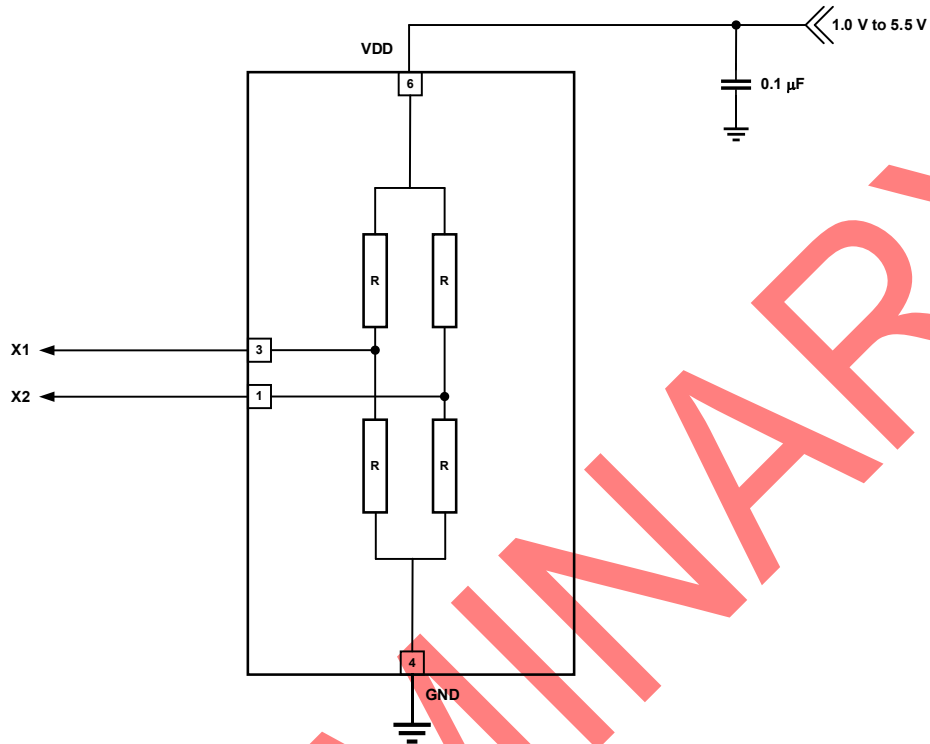

Figure 10. CT100 Application Diagram

Table 1. Recommended External Components

Component	Description	Vendor & Part Number	Parameter	Min.	Typ.	Max.	Unit
C <sub>BYP</sub>	0.1 μF, X7R	Murata GRM033Z71A104KE14	C		0.1		μF
		Others					

SOT23-6 Package Drawing and Dimensions

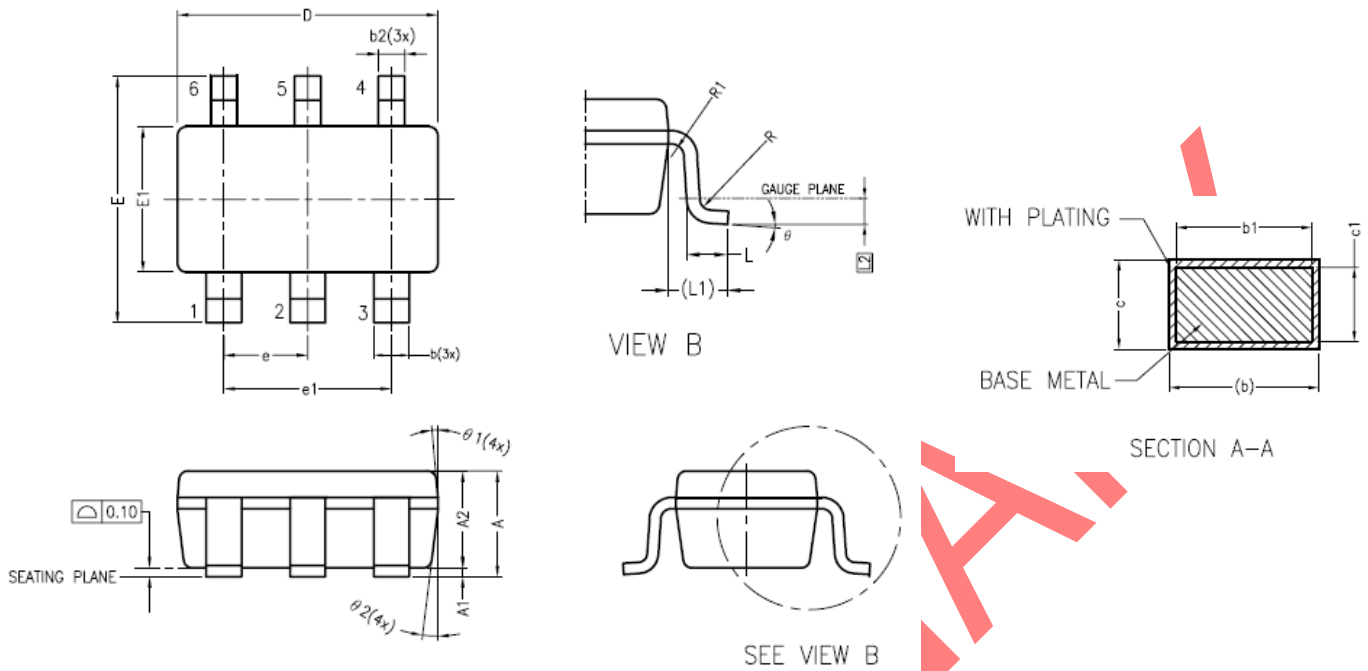

Figure 11. 6-Lead SOT23 Package Drawing

Table 2. CT100 6-Lead SOT23 Package Dimensions

Symbol	Dimensions in Millimeters (mm)		
	Min.	Typ.	Max.
A	1.05	1.20	1.35
A1	0.00	0.10	0.15
A2	1.00	1.10	1.20
b	0.40	-	0.50
b1	0.40	0.40	0.45
c	0.08	-	0.22
c1	0.08	0.13	0.20
D	2.80	2.90	3.00
E	2.60	2.80	3.00
E1	1.50	1.60	1.70
e	0.95 BSC		
e1	1.90 BSC		
L	0.35	0.43	0.60
L1	0.60 REF		
L2	0.25 BSC		
R	0.10	-	-
R1	0.10	-	0.25
theta	0°	4°	8°
theta1	5°	6°	15°
theta2	5°	8°	15°

Crocus Technology provides package drawings as a service to customers considering or planning to use Crocus products in their designs. Drawings may change without notice. Please note the revision and date of the data sheet and contact a Crocus Technology representative to verify or obtain the most recent version. The package specifications do not expand the terms of Crocus Technology's worldwide terms and conditions, specifically the warranty therein, which covers Crocus Technology's products.

## DFN-6 Package Drawing and Dimensions

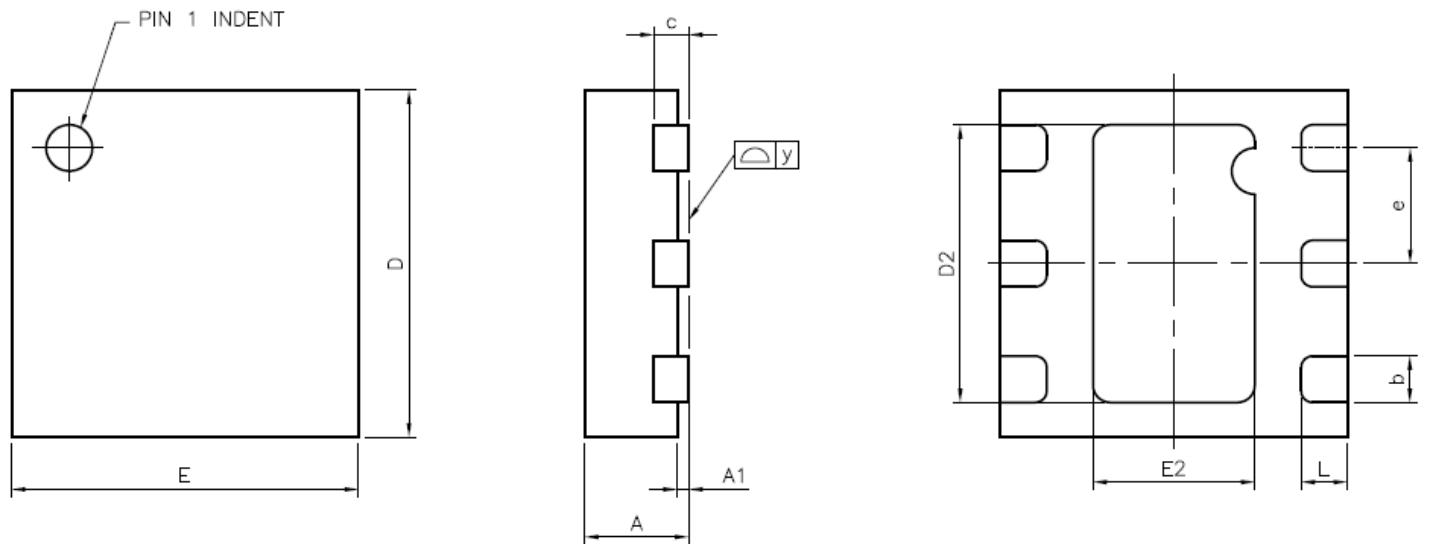

Figure 12. DFN-6 Package Drawing

Table 3. CT100 DFN-6 Package Dimensions

Symbol	Dimensions in Millimeters (mm)		
	Min.	Typ.	Max.
A	0.40	0.45	0.50
A1	0.00	0.02	0.05
b	0.15	0.20	0.25
c	-	0.15 REF	-
D	1.40	1.50	1.60
D2	1.15	1.20	1.25
E	1.40	1.50	1.60
E2	0.65	0.70	0.75
e	-	0.50	-
L	0.15	0.20	0.25
y	0.000	-	0.075

Crocus Technology provides package drawings as a service to customers considering or planning to use Crocus products in their designs. Drawings may change without notice. Please note the revision and date of the data sheet and contact a Crocus Technology representative to verify or obtain the most recent version. The package specifications do not expand the terms of Crocus Technology's worldwide terms and conditions, specifically the warranty therein, which covers Crocus Technology's products.

## Package Information

Table 4. CT100 Package Information

Part Number	Package Type	# of Leads	Package Quantity	Lead Finish	Eco Plan <sup>(1)</sup>	MSL Rating <sup>(2)</sup>	Operating Temperature <sup>(3)</sup>	Device Marking
CT100LW-IS6	SOT23	6	3,000	Sn	Green & RoHS	1	-40°C to +85°C	CT YWWS
CT100LW-HS6	SOT23	6	3,000	Sn	Green & RoHS	1	-40°C to +125°C	CT YWWS
CT100LW-FS6	SOT23	6	3,000	Sn	Green & RoHS	1	-40°C to +150°C	CT YWWS
CT100LW-ID6	DFN	6	3,000	Sn	Green & RoHS	1	-40°C to +85°C	C YZ
CT100LW-HD6	DFN	6	3,000	Sn	Green & RoHS	1	-40°C to +125°C	C YZ
CT100LW-FD6	DFN	6	3,000	Sn	Green & RoHS	1	-40°C to +150°C	C YZ

- (1) RoHS is defined as semiconductor products that are compliant to the current EU RoHS requirements. It also will meet the requirement that RoHS substances do not exceed 0.1% by weight in homogeneous materials. Green is defined as the content of Chlorine (Cl), Bromine (Br) and Antimony Trioxide based flame retardants satisfy JS709B low halogen requirements of  $\leq 1,000$  ppm.
- (2) MSL Rating = Moisture Sensitivity Level Rating as defined by JEDEC standard classifications.
- (3) Package will withstand ambient temperature range of -40°C to +150°C and storage temperature range of -65°C to +160°C.
- (4) Device Marking for SOT23 is defined as XZ YWWS where XZ = part number, Y = year, WW = work week and S = sequential number. DFN is defined as X where X = part number and YZ = date code information.

**Disclaimer:** The contents of this document are provided for informational purposes only. CROCUS TECHNOLOGY, INC. AND CROCUS TECHNOLOGY SA (COLLECTIVELY “CROCUS”) MAKE NO REPRESENTATIONS OR WARRANTY OF ANY KIND, EXPRESS OR IMPLIED, WITH RESPECT TO THE ACCURACY OR COMPLETENESS OF THE CONTENTS HEREIN, INCLUDING, BUT NOT LIMITED TO, THE IMPLIED WARRANTIES OF MERCHANTABILITY AND FITNESS FOR A PARTICULAR PURPOSE. Crocus reserves the right to make changes to the specifications and product descriptions, and/or to discontinue or make changes to its products at any time without notice. Crocus’s products have not been designed, tested, or manufactured for use and should not be used in applications where the failure, malfunction or inaccuracy of the Products carries a risk of death or serious bodily injury or damage to tangible property, including, but not limited to, life support systems, nuclear facilities, military, aircraft navigation or communication, emergency systems, harsh environments, or other applications with a similar degree of potential hazard.

## Product Status Definition

Data Sheet Identification	Product Status	Definition
Objective	Proposed New Product Idea or In Development	Data sheet contains design target specifications and are subject to change without notice at any time.
Preliminary	First Production	Data sheet contains preliminary specifications obtained by measurements of early samples. Follow-on data will be published at a later date as more test data is acquired. Crocus reserves the right to make changes to the data sheet at any time.
None	Full Production	Data sheet contains final specifications for all parameters. Crocus reserves the right to make changes to the data sheet at any time.
Obsolete	Not in Production	Data sheet for a product that is no longer in production at Crocus. It is for reference only.

# Mouser Electronics

Authorized Distributor

Click to View Pricing, Inventory, Delivery & Lifecycle Information:

[Crocus Technology:](#)

[CT100LW-HS6](#) [CT100LW-IS6](#) [CT100LW-ID6](#) [CT100LW-HD6](#) [CT100LW-FS6](#) [CT100LW-FD6](#)