

FEATURES

- Switching and Amplifier Applications
- Suitable for automatic insertion in thick and thin-film circuits
- Low Noise: BC859, BC860
- Complement to BC846 ... BC850

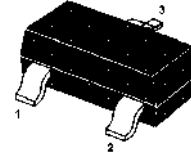

1.Base 2.Emitter 3.Collector
SOT-23 Plastic Package

Absolute Maximum Ratings ($T_a = 25\text{ }^\circ\text{C}$)

Parameter	Symbol	Value	Unit	
Collector Base Voltage	BC856	$-V_{CBO}$	80	V
	BC857, BC860	$-V_{CBO}$	50	V
	BC858, BC859	$-V_{CBO}$	30	V
Collector Emitter Voltage	BC856	$-V_{CEO}$	65	V
	BC857, BC860	$-V_{CEO}$	45	V
	BC858, BC859	$-V_{CEO}$	30	V
Emitter Base Voltage	$-V_{EBO}$	5	V	
Collector Current	$-I_C$	100	mA	
Peak Collector Current	$-I_{CM}$	200	mA	
Power Dissipation	P_{tot}	300	mW	
Thermal Resistance from Junction to Ambient Air	$R_{\theta JA}$	417	$^\circ\text{C/W}$	
Junction Temperature	T_j	150	$^\circ\text{C}$	
Storage Temperature Range	T_{stg}	- 65 to + 150	$^\circ\text{C}$	

ELECTRICAL CHARACTERISTICS (T_A=25°C)

Parameter	Symbol	Min.	Max.	Unit	
DC Current Gain at -V _{CE} = 5 V, -I _C = 2 mA Current Gain Group	A	110	220	-	
	B	200	450	-	
	C	420	800	-	
Collector Base Cutoff Current at -V _{CB} = 30 V	-I _{CBO}	-	15	nA	
Collector Base Breakdown Voltage at -I _C = 10 μA	BC856	-V _{(BR)CBO}	80	-	V
	BC857, BC860	-V _{(BR)CBO}	50	-	V
	BC858, BC859	-V _{(BR)CBO}	30	-	V
Collector Emitter Breakdown Voltage at -I _C = 10 μA	BC856	-V _{(BR)CES}	80	-	V
	BC857, BC860	-V _{(BR)CES}	50	-	V
	BC858, BC859	-V _{(BR)CES}	30	-	V
Collector Emitter Breakdown Voltage at -I _C = 10 mA	BC856	-V _{(BR)CEO}	65	-	V
	BC857, BC860	-V _{(BR)CEO}	45	-	V
	BC858, BC859	-V _{(BR)CEO}	30	-	V
Emitter Base Breakdown Voltage at -I _E = 1 μA	-V _{(BR)EBO}	5	-	V	
Collector Emitter Saturation Voltage at -I _C = 10 mA, -I _B = 0.5 mA at -I _C = 100 mA, -I _B = 5 mA	-V _{CE(sat)}	-	0.3	V	
	-V _{CE(sat)}	-	0.65	V	
Base Emitter On Voltage at -I _C = 2 mA, -V _{CE} = 5 V at -I _C = 10 mA, -V _{CE} = 5 V	-V _{BE(on)}	0.6	0.75	V	
	-V _{BE(on)}	-	0.82	V	
Current Gain Bandwidth Product at -V _{CE} = 5 V, -I _C = 10 mA, f = 100 MHz	f _T	100	-	MHz	
Output Capacitance at -V _{CB} = 10 V, f = 1 MHz	C _{ob}	-	6	pF	
Noise Figure at -I _C = 200 μA, -V _{CE} = 5 V, R _G = 2 KΩ, f = 1 KHz at -I _C = 200 μA, -V _{CE} = 5 V, R _G = 2 KΩ, f = 30 ~15 KHz	NF	BC856, BC857, BC858	-	10	dB
		BC859, BC860	-	4	
		BC859	-	4	
		BC860	-	2	

MARKING

TYPE	856A	856B	856C	857A	857B	857C	858A	858B	858C	859A	859B	859C	860A	860B	860C
MARK	3A	3B	3C	3E	3F	3G	3J	3K	3L	4A	4B	4C	4E	4F	4G

Typical Characteristics

Figure 1. Static Characteristic

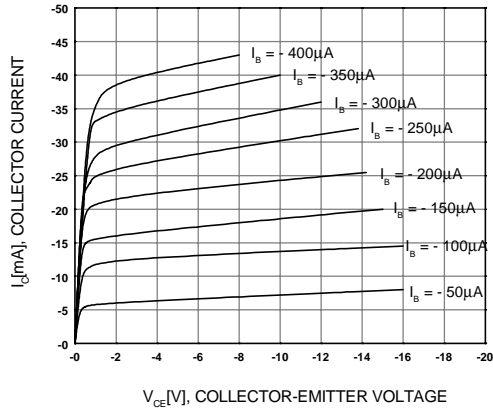

Figure 2. DC current Gain

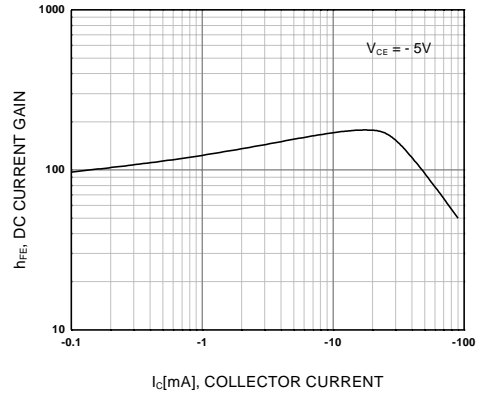

Figure 3. Base-Emitter Saturation Voltage
Collector-Emitter Saturation Voltage

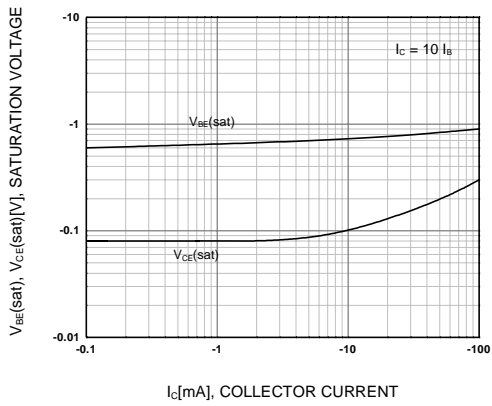

Figure 4. Base-Emitter On Voltage

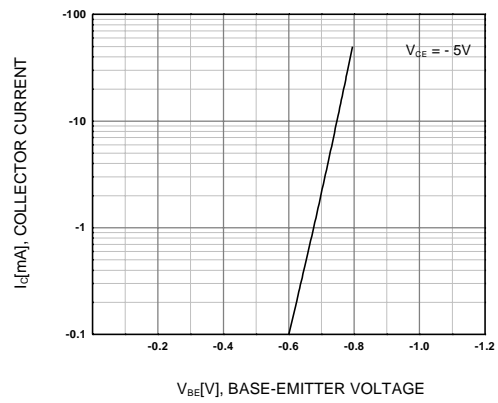

Figure 5. Collector Output Capacitance

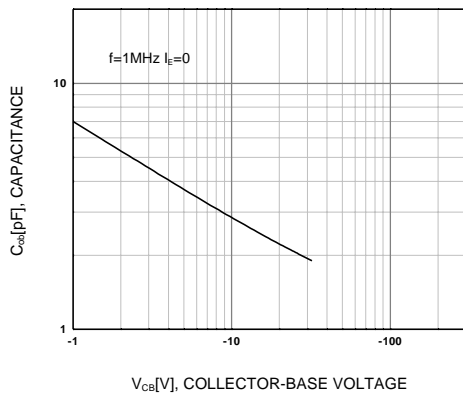
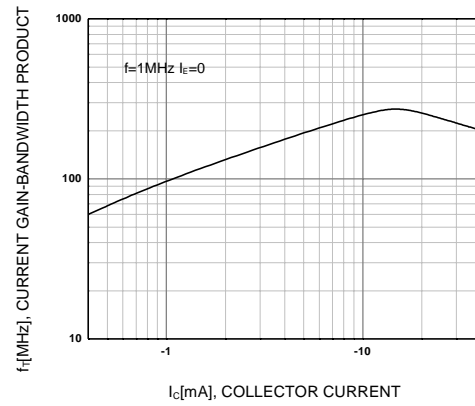

Figure 6. Current Gain Bandwidth Product



PACKAGE OUTLINE

Plastic surface mounted package; 3 leads

SOT-23

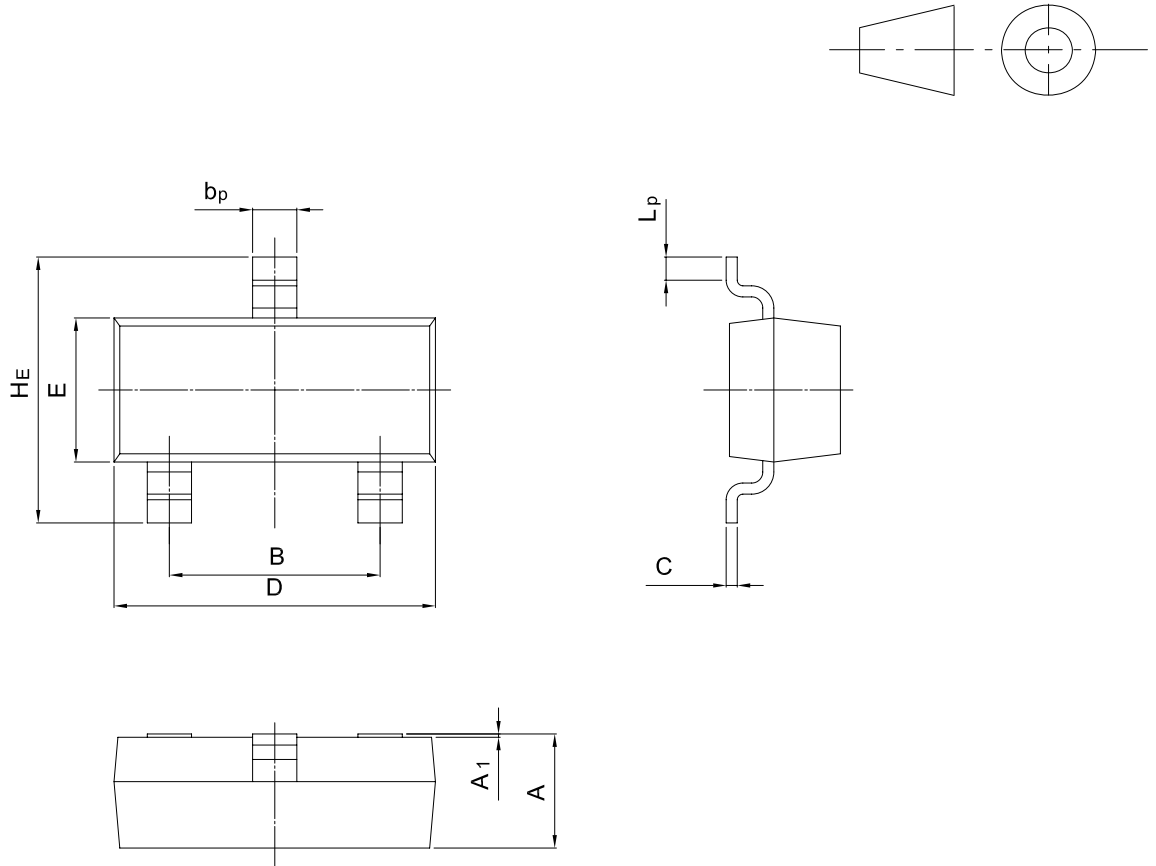

UNIT	A	B	bp	C	D	E	HE	A1	Lp
mm	1.40	2.04	0.50	0.19	3.10	1.65	3.00	0.100	0.50
	0.95	1.78	0.35	0.08	2.70	1.20	2.20	0.013	0.20