

# TLV4946-2L

## Value Optimized Hall Effect Latch for Industrial and Consumer Applications

### About this document

#### Overview

The TLV4946-2L is a high precision Hall Effect Latch with highly accurate switching thresholds for ambient operating temperatures up to 85°C.



#### Features

- 2.7 V to 18 V supply voltage operation.
- Operation from unregulated power supply.
- High sensitivity and high stability of the magnetic switching points.
- High resistance to mechanical stress by active error compensation.
- Reverse battery protection (-18 V).
- Superior temperature stability.
- Low jitter (typically 1  $\mu$ s).
- High ESD performance ( $\pm$  4 kV HBM).
- Digital output signal (open-drain).
- Not suitable for automotive applications

#### Target applications

The TLV4946-2L is ideally suited to detect the rotor position in Brushless DC (BLDC) Motors used in industrial and consumer applications, such as: air conditioning systems, pumps, washing machines, DVD players, rolling shutter, etc. The sensor also provides a reliable switching for index counting with small pole wheels and large air gaps. The TLV4946-2L can also be used for index counting.

Product name	Product type	Ordering code	Package
TLV4946-2L	Hall Effect Latch	SP000604340	PG-SSO-3-2

## Table of contents

	<b>About this document</b> .....	1
	<b>Table of contents</b> .....	2
<b>1</b>	<b>Functional description</b> .....	3
1.1	General .....	3
1.2	Pin configuration .....	3
1.3	Pin description .....	3
1.4	Block diagram .....	4
1.5	Operating modes and states .....	4
1.6	Functional block description .....	5
<b>2</b>	<b>Specification</b> .....	6
2.1	Application circuit .....	6
2.2	Absolute maximum ratings .....	6
2.3	Operating range .....	7
2.4	Electrical characteristics .....	7
<b>3</b>	<b>Package information</b> .....	9
3.1	TLV4946-2L Package outline .....	9
<b>4</b>	<b>Revision history</b> .....	11
	<b>Disclaimer</b> .....	12

**1 Functional description**

**1 Functional description**

**1.1 General**

Precise magnetic switching thresholds and high temperature stability are achieved by active compensation circuits and chopper techniques on chip. Offset voltages generated by temperature-induced stress or overmolding are canceled so that high accuracy is achieved. The IC has an open collector output stage with 20 mA current sink capability. A wide operating voltage range from 2.7 V to 18 V with reverse polarity protection down to -18 V makes the TLV4946-2L suitable for a wide range of applications. A magnetic south pole with a field strength above  $B_{op}$  turns the output on. A magnetic north pole exceeding  $B_{rp}$  turns it off.

**1.2 Pin configuration**

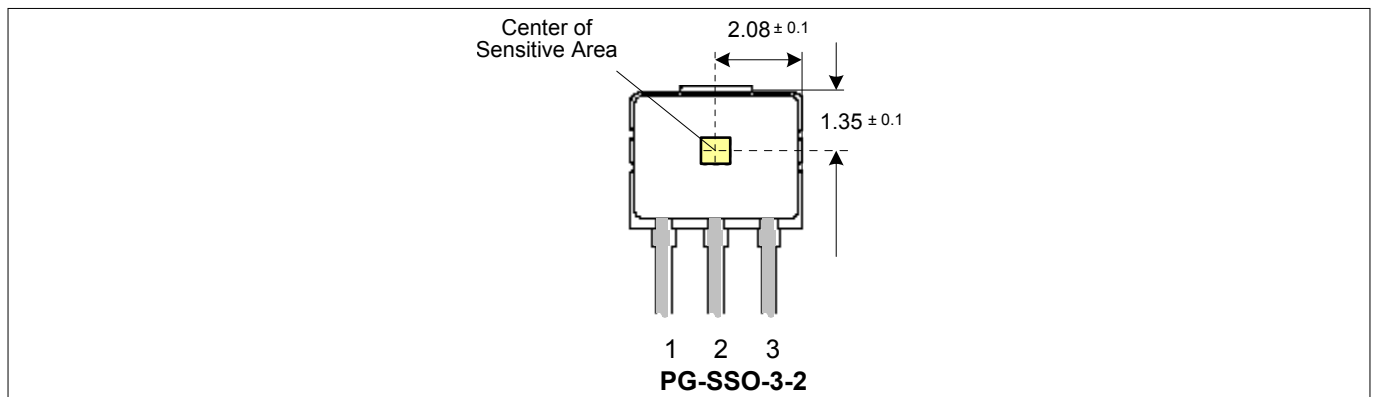

**Figure 1 Pin configuration and sensitive area (Top view, figure not to scale)**

**1.3 Pin description**

**Table 1 Pin definitions for the PG-SSO-3-2 package**

Pin No.	Name	Function
1	$V_S$	Supply Voltage
	$GND$	Ground
3	$Q$	Output

**1 Functional description**

**1.4 Block diagram**

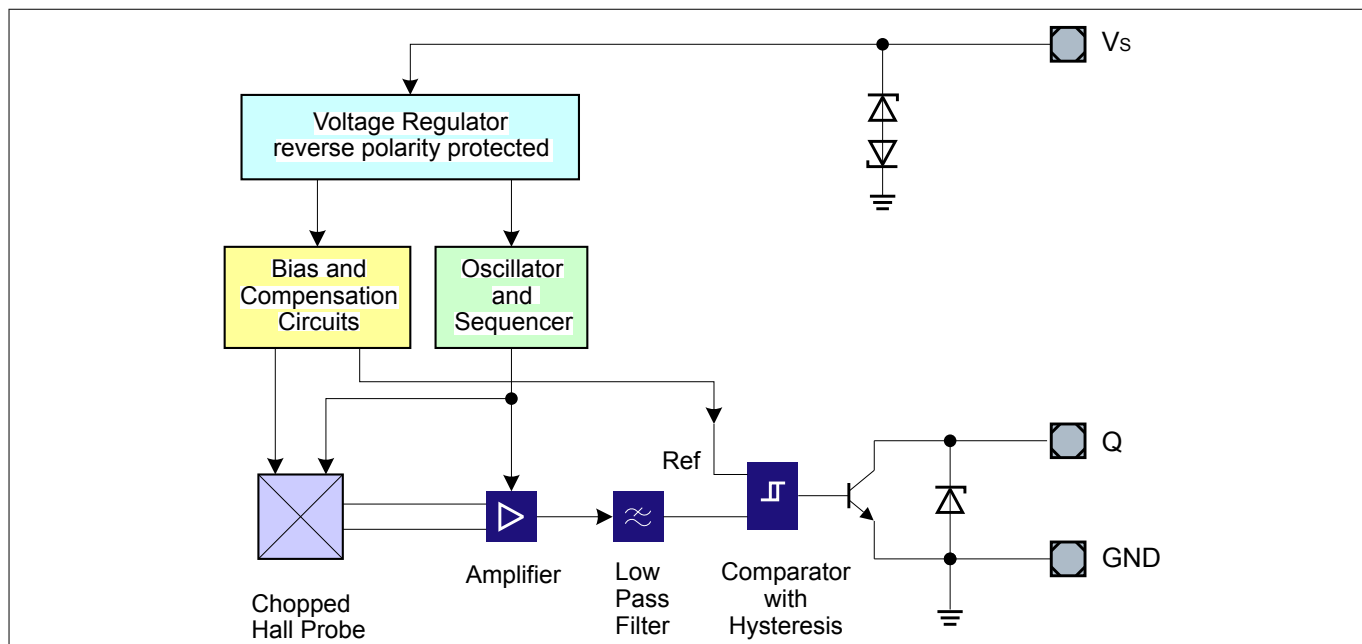
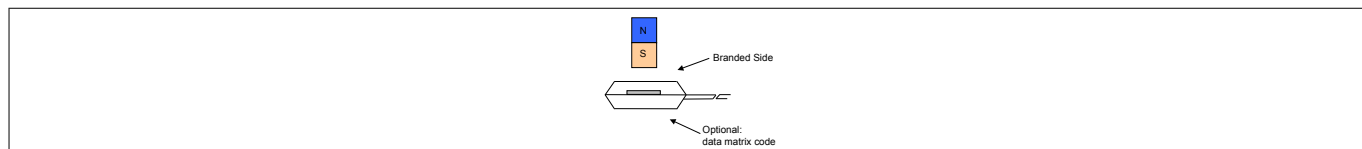

**Figure 2 TLV4946-2L Block diagram**

**1.5 Operating modes and states**

**Field Direction and Definition**

Positive magnetic fields correspond to the south pole of the magnet targeting the branded side of the package.



**Figure 3 Definition of the magnetic field direction**

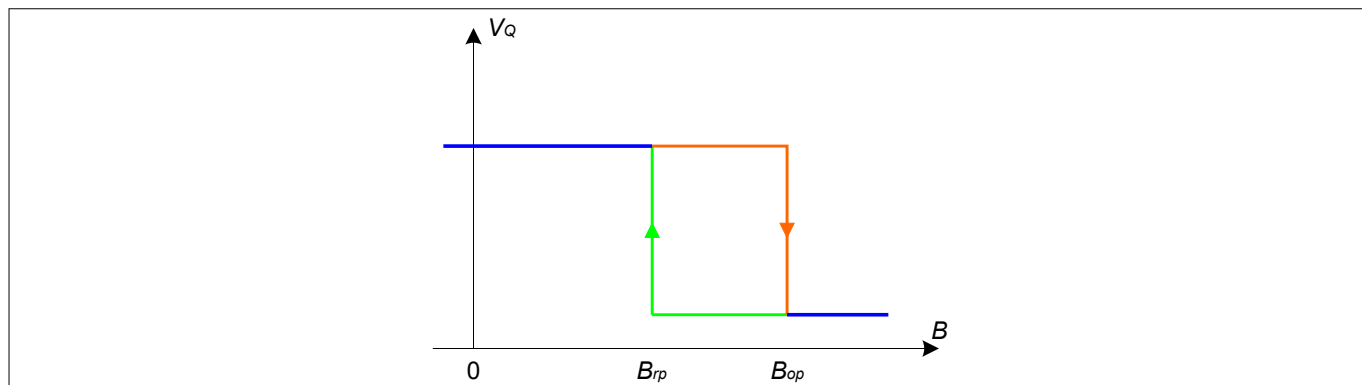

**Figure 4 Output signal**

---

**1 Functional description****1.6 Functional block description**

The chopped Hall Effect Latch comprises a Hall probe, a bias generator, compensation circuits, an oscillator and an output transistor. The bias generator provides currents to the Hall probe and the active circuits. Compensation circuits stabilize response of the IC over temperature and reduce the impact of process variations. The Active Error Compensation rejects offsets in the signal path and reduces the impact of mechanical stress in the package caused by molding, soldering and thermal effects. The chopper technique together with the threshold generator and the comparator ensure high accurate magnetic switching points.

**2 Specification**

**2 Specification**

**2.1 Application circuit**

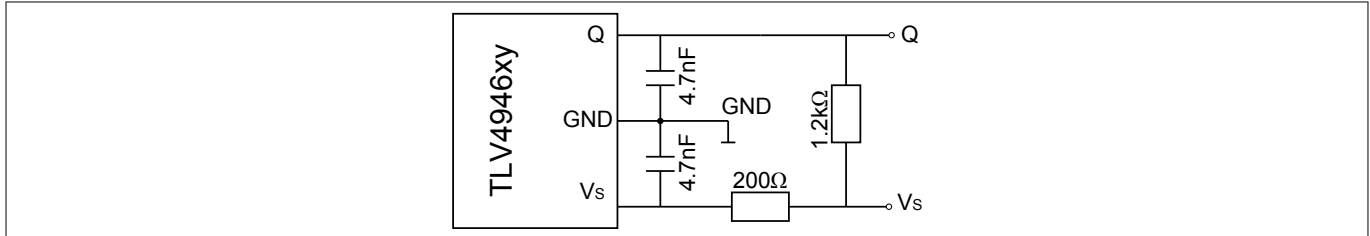

**Figure 5 Application circuit**

It is recommended to use a resistor of 200 Ω in the supply line for current limitation in the case of an overvoltage pulse. Two capacitors of 4.7 nF enhance the EMC performance. The pull-up of 1.2 kΩ limits the current through the output transistor.

**2.2 Absolute maximum ratings**

Stress above the maximum values listed in this section may cause permanent damage to the device. Exposure to absolute maximum rating conditions for extended periods may affect the reliability of the device. Exceeding only one of these values may cause irreversible damage to the device.

**Table 2 Absolute maximum ratings**

Parameter	Symbol	Values			Unit	Note/Test Condition
		Min.	Typ.	Max.		
Maximum Ambient Temperature	$T_A$	-40	-	125	°C	
Maximum Junction Temperature	$T_J$	-40	-	150	°C	
Supply Voltage	$V_S$	-18	-	18	V	
Supply current through protection device	$I_S$	-50	-	50	mA	
Output Voltage	$V_{OUT}$	-0.7	-	18	V	
Storage Temperature	$T_S$	-40	-	150	°C	
Magnetic flux density	$B$	-	-	unlimited	mT	
ESD Robustness HBM: 1.5 kΩ, 100 pF	$V_{ESD,HBM}^{(1)}$	-	-	4	kV	

(1) According to EIA/JESD22-A114-E

## 2 Specification

### 2.3 Operating range

The following operating conditions must not be exceeded in order to ensure correct operation of the TLV4946xy. All parameters specified in the following sections refer to these operating conditions unless otherwise mentioned.

**Table 3** Operating range

Parameter	Symbol	Values			Unit	Note/Test Condition
		Min.	Typ.	Max.		
Supply Voltage	$V_S$	2.7	–	18	V	
Output Voltage	$V_Q$	-0.7	–	18	V	
Output Current	$I_Q$	0	–	20	mA	
Maximum Ambient Temperature	$T_A$	-40	–	85	°C	

### 2.4 Electrical characteristics

Product characteristics include the spread of values guaranteed within the specified voltage and ambient temperature range. typical characteristics are the median of the production (at  $V_S = 12\text{ V}$  and  $T_A = 25^\circ\text{C}$ ).

**Table 4** Electrical characteristics

Parameter	Symbol	Values			Unit	Note/Test Condition
		Min.	Typ.	Max.		
Supply Current	$I_S$	2	4	6	mA	$V_S = 2.7\text{ V} \dots 18\text{ V}$
Reverse Current	$I_{SR}$	0	0.2	1	mA	$V_S = -18\text{ V}$
Output Saturation Voltage	$V_{QSAT}$	–	0.3	0.6	V	$I_Q = 20\text{ mA}$
Output leakage current	$I_{QLEAK}$	–	0.05	10	$\mu\text{A}$	$V_Q = 18\text{ V}$
Output fall time <sup>(1)</sup>	$t_f$	–	0.02	1	$\mu\text{s}$	$R_L = 1.2\text{ k}\Omega$ , $C_L = 50\text{ pF}$
Output rise time <sup>(1)</sup>	$t_r$	–	0.4	1	$\mu\text{s}$	
Chopper frequency	$f_{OSC}$	–	320	–	kHz	
Switching frequency	$f_{SW}$	0	–	15 <sup>(2)</sup>	kHz	
Delay time <sup>(3)</sup>	$t_d$	–	13	–	$\mu\text{s}$	
Output jitter <sup>(4)</sup>	$t_{QJ}$	–	1	–	$\mu\text{s}_{RMS}$	Typical value for a 1 kHz square wave signal
Power-on Time <sup>(5)</sup>	$t_{PON}$	–	13	–	$\mu\text{s}$	$V_S > 2.7\text{ V}$
Thermal Resistance junction to ambient <sup>(6)</sup>	$R_{thja}$	–		190	K/W	TLV4946-2L

(1) See [Figure 6](#)

(2) To operate the sensor at maximum switching frequency, the value of the magnetic signal amplitude must be 1.4 times higher than the static fields. This is due to the -3 dB corner frequency of the low pass filter in the signal path.

(3) Systematic delay between magnetic threshold reached and output.

2 Specification

- (4) Jitter is the unpredictable deviation of the output switching delay.
- (5) Time from applying  $V_S > 2.7\text{ V}$  to the sensor until the output state is valid.
- (6) Relationship between junction and ambient temperature:  $T_J = T_{amb} + R_{thja} \cdot (V_S \cdot I_S + V_{QS} \cdot I_Q)$ .

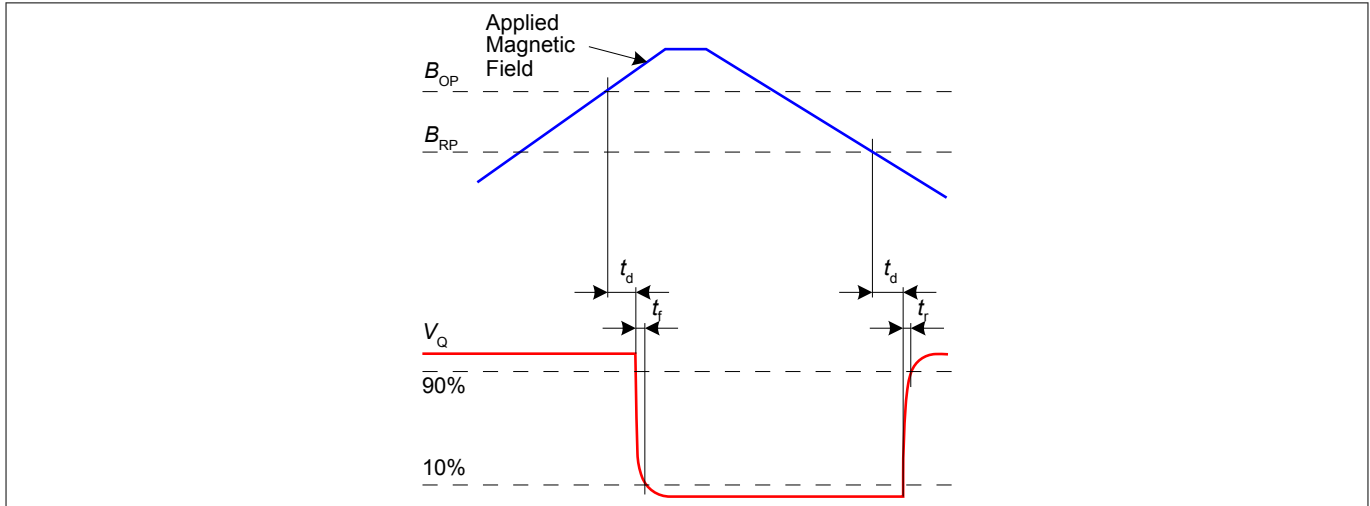

Figure 6 Timing diagram

Table 5 Magnetic characteristics<sup>(1)</sup>

Parameter	Symbol	Values			Unit	Note/Test Condition
		Min.	Typ.	Max.		
Operate point	$B_{OP}$	0.5	2.0	3.5	mT	
Release point	$B_{RP}$	-3.5	-2.0	-0.5	mT	
Hysteresis	$B_{HYS}$	1.0	4.0	6.0	mT	
Magnetic offset <sup>(2)</sup>	$B_{OFF}$	-1.5	0	1.5	mT	
Temperature compensation of magnetic thresholds	$TC$	-	-350	-	ppm/ $^{\circ}\text{C}$	
Repeatability of magnetic thresholds <sup>(3)</sup>	$B_{REP}$	-	20	-	$\mu\text{T}_{RMS}$	typical value for $\Delta B/\Delta t > 12\text{ mT/ms}$

- (1) Over all operating conditions
- (2)  $B_{OFF} = (B_{OP} + B_{RP}) / 2$ .
- (3)  $B_{REP}$  is equivalent to the noise constant.

**3 Package information**

**3 Package information**

**3.1 TLV4946-2L Package outline**

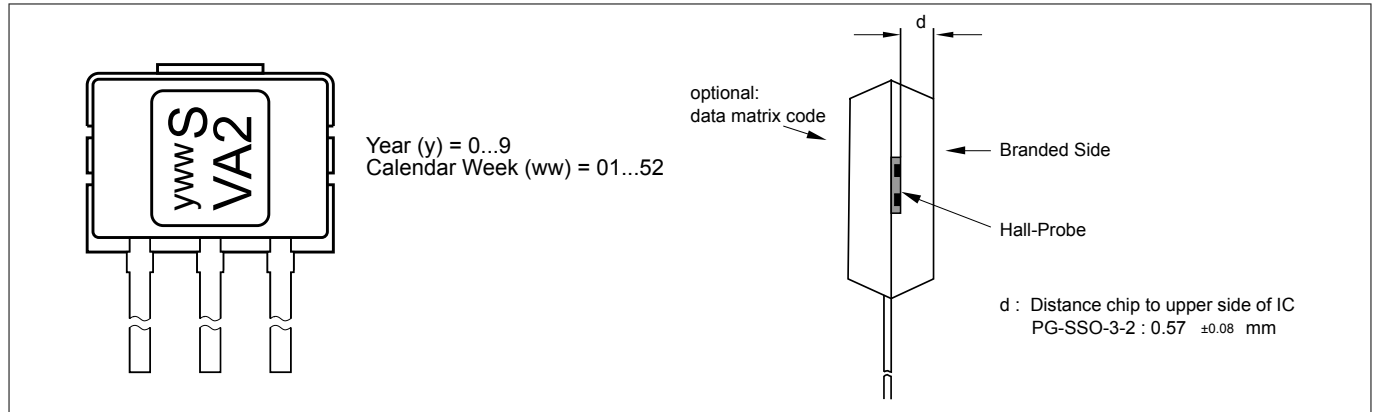

**Figure 7 Marking of the TLV4946-2L and distance of the chip to the upper side**

3 Package information

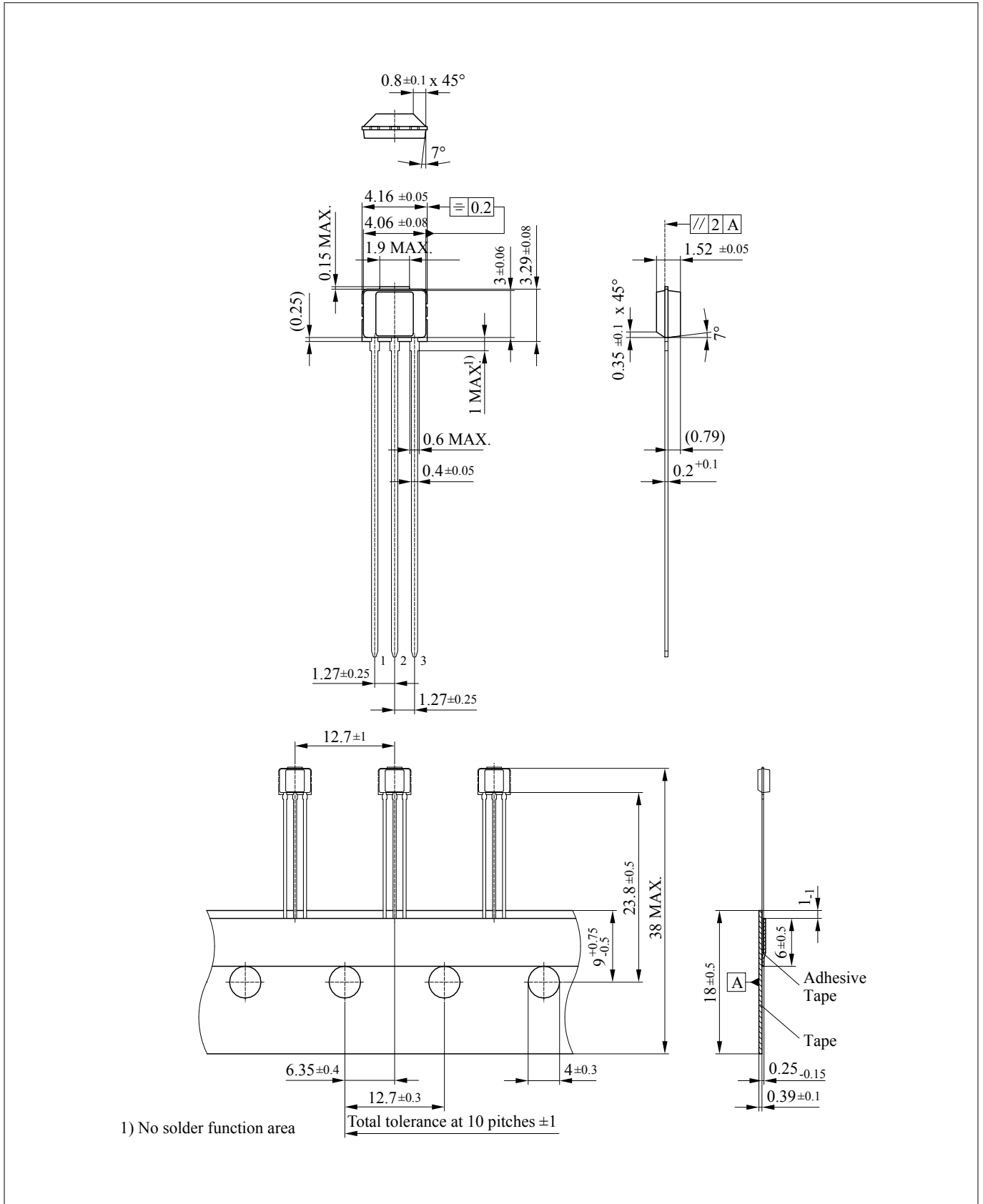

Figure 8 PG-SSO-3-2 Package Outline

---

**4 Revision history**

**4 Revision history**

---

**Revision History**

<b>Page</b>	<b>Subjects (major changes since last revision)</b>
Revision History: 2020-08, Rev 1.2	
Previous Revisions: 1.1	
10	Edited figure 6 (optional: data matrix code)

## Trademarks

All referenced product or service names and trademarks are the property of their respective owners.

**Edition 2020-08**

**Published by**

**Infineon Technologies AG**

**81726 Munich, Germany**

**© 2020 Infineon Technologies AG**

**All Rights Reserved.**

**Do you have a question about any aspect of this document?**

**Email: [erratum@infineon.com](mailto:erratum@infineon.com)**

**Document reference**

**IFX-haz1599140991641**

## IMPORTANT NOTICE

The information given in this document shall in no event be regarded as a guarantee of conditions or characteristics ("Beschaffheitsgarantie").

With respect to any examples, hints or any typical values stated herein and/or any information regarding the application of the product, Infineon Technologies hereby disclaims any and all warranties and liabilities of any kind, including without limitation warranties of non-infringement of intellectual property rights of any third party.

In addition, any information given in this document is subject to customer's compliance with its obligations stated in this document and any applicable legal requirements, norms and standards concerning customer's products and any use of the product of Infineon Technologies in customer's applications.

The data contained in this document is exclusively intended for technically trained staff. It is the responsibility of customer's technical departments to evaluate the suitability of the product for the intended application and the completeness of the product information given in this document with respect to such application.

## WARNINGS

Due to technical requirements products may contain dangerous substances. For information on the types in question please contact your nearest Infineon Technologies office.

Except as otherwise explicitly approved by Infineon Technologies in a written document signed by authorized representatives of Infineon Technologies, Infineon Technologies' products may not be used in any applications where a failure of the product or any consequences of the use thereof can reasonably be expected to result in personal injury.