



LM SERIES

FLOAT SWITCH FOR TURBULENT LIQUIDS AND CONFINED SPACES



This is suitable for use in water, industrial wastewater and sewage, that can have wide variations of temperature. This small design of switch is for use in more confined spaces, where there is not enough room for the larger FFSMC type.

The rounded body design and floating attitude prevents accumulation of solids on the body. The switch has additional internal ballast, to bring the centre of gravity and rotation close to the cable entry point.

The switching element is a self cleaning type, that makes the complete switch insensitive to humidity and condensation, allowing this type to operate in widely fluctuating temperatures. The switch contacts are rated at 10 Amp resistive.

Supplied, as standard, with 5 metres cable and adjustable counterweight.

Features

- For smaller tanks and restricted space
- Use in sewer and industrial waste water
- Shape avoids "ragging", in sewer systems
- Unaffected by suspended solids
- Operates in Turbulent Fluids

SPECIFICATIONS

Technical

		LM10A	LM10B	LM10C
Contact Form		N/O	N/C	C/O
Material		High Density Polyethylene		
Temp Range	°C	0 / +55		
	°F	+ 32 / +131		
Cable (standard length 5m)		With protective earth	no earth	
Standard cable covering		PVC		
U cable option for Fuel oils		Polyurethane		
Max. working pressure		10 bar		

Electrical

Power Rating Max	AC : 750 VA DC : 180W
Switching Voltage Max	AC : 250 V DC : 110 V
Switching Current Max. Resistive	10 A
Switching Current Max. Inductive	AC : 4A DC : 1 A

It is necessary to use an auxiliary relay, when switching pump motors or any loads that are not purely resistive.

DIMENSIONS

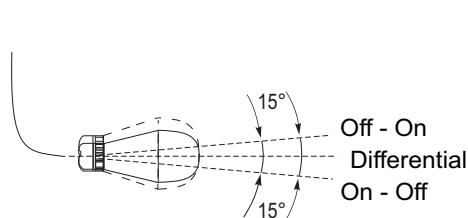

Minimum Cable Pivot
length 120mm

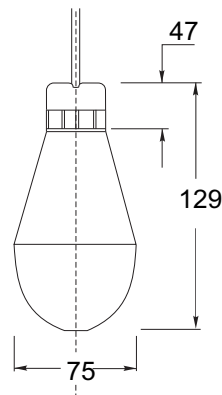

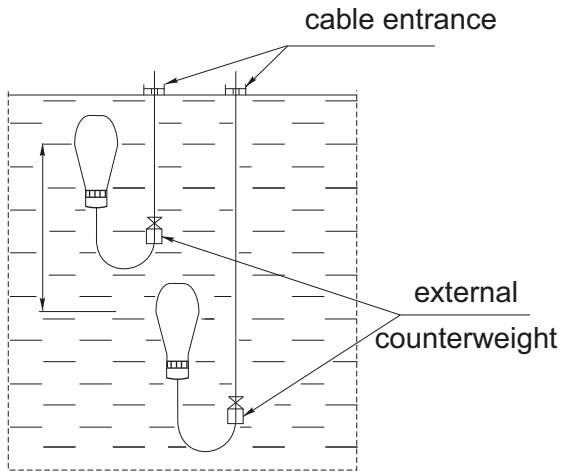

wiring diagram
for filling pump

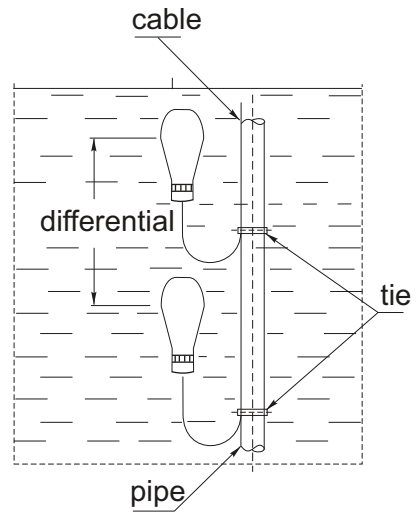
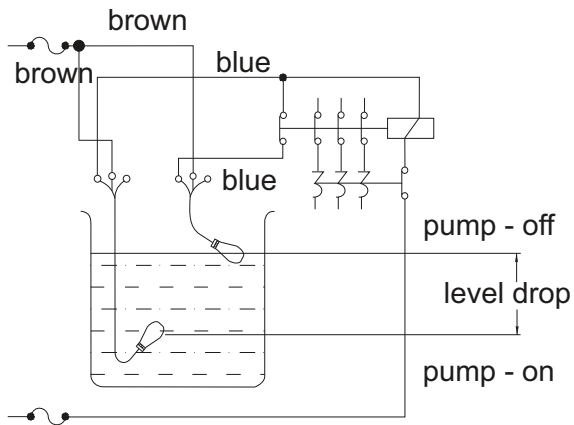

wiring diagram
for emptying pump

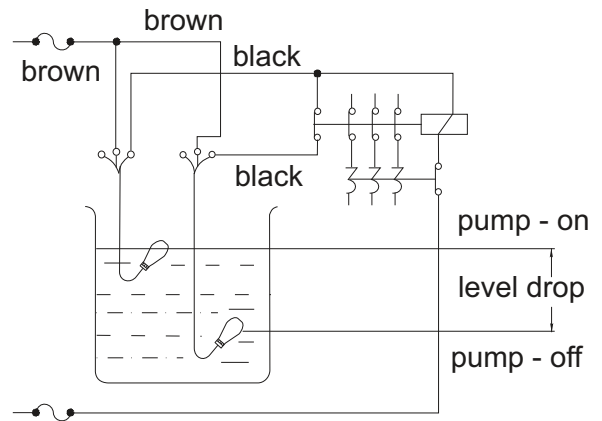

ORDERING OPTIONS

Example : LM10AU10

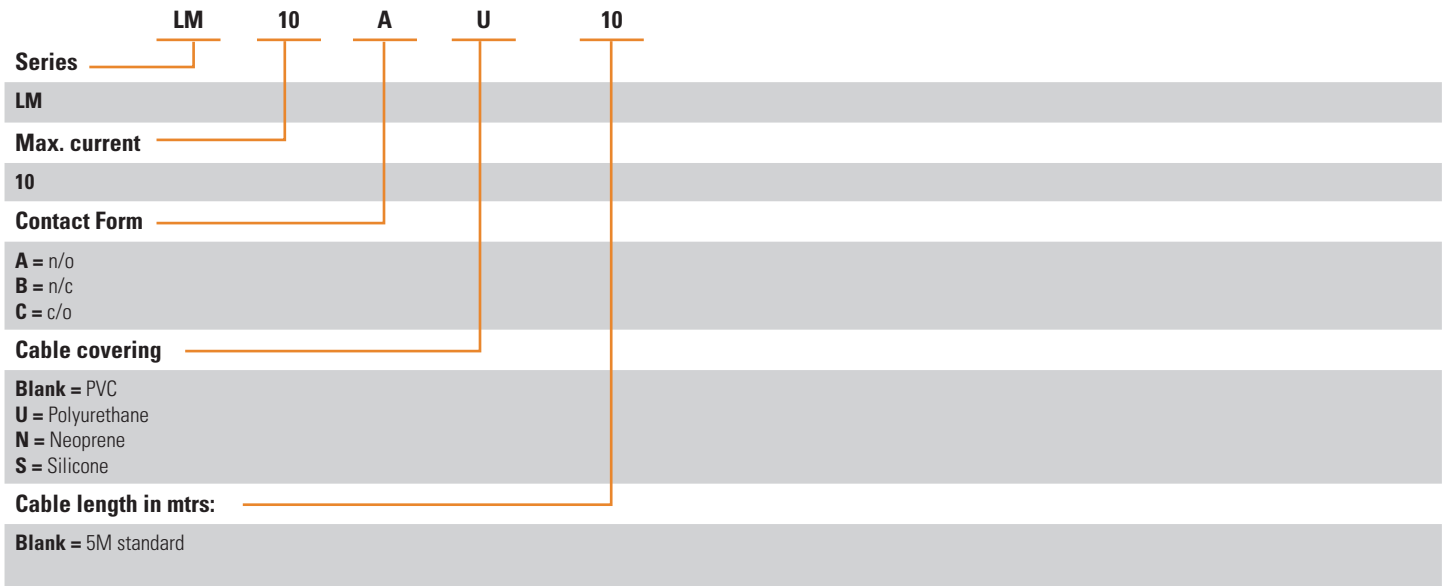

Datasheets provided by Sensata Technologies, Inc., its subsidiaries and/or affiliates ("Sensata") are solely intended to assist third parties ("Buyers") who are developing systems that incorporate Sensata products (also referred to herein as "components"). Buyer understands and agrees that Buyer remains responsible for using its independent analysis, valuation, and judgment in designing Buyer's systems and products. Sensata datasheets have been created using standard laboratory conditions and engineering practices. Sensata has not conducted any testing other than that specifically described in the published documentation for a particular datasheet. Sensata may make corrections, enhancements, improvements, and other changes to its datasheets or components without notice.

Buyers are authorized to use Sensata datasheets with the Sensata component(s) identified in each particular datasheet. HOWEVER, NO OTHER LICENSE, EXPRESS OR IMPLIED, BY ESTOPPEL OR OTHERWISE TO ANY OTHER SENSATA INTELLECTUAL PROPERTY RIGHT, AND NO LICENSE TO ANY THIRD PARTY TECHNOLOGY OR INTELLECTUAL PROPERTY RIGHT, IS GRANTED HEREIN. SENSATA DATASHEETS ARE PROVIDED "AS IS". SENSATA MAKES NO WARRANTIES OR REPRESENTATIONS WITH REGARD TO THE DATASHEETS OR USE OF THE DATASHEETS, EXPRESS, IMPLIED, OR STATUTORY, INCLUDING ACCURACY OR COMPLETENESS. SENSATA DISCLAIMS ANY WARRANTY OF TITLE AND ANY IMPLIED WARRANTIES OF MERCHANTABILITY, FITNESS FOR A PARTICULAR PURPOSE, QUIET ENJOYMENT, QUIET POSSESSION, AND NON-INFRINGEMENT OF ANY THIRD PARTY INTELLECTUAL PROPERTY RIGHTS WITH REGARD TO SENSATA DATASHEETS OR USE THEREOF.

All products are sold subject to Sensata's terms and conditions of sale supplied at www.sensata.com. SENSATA ASSUMES NO LIABILITY FOR APPLICATIONS ASSISTANCE OR THE DESIGN OF BUYERS' PRODUCTS. BUYER ACKNOWLEDGES AND AGREES THAT IT IS SOLELY RESPONSIBLE FOR COMPLIANCE WITH ALL LEGAL, REGULATORY, AND SAFETY-RELATED REQUIREMENTS CONCERNING ITS PRODUCTS, AND ANY USE OF SENSATA COMPONENTS IN ITS APPLICATIONS, NOTWITHSTANDING ANY APPLICATIONS- RELATED INFORMATION OR SUPPORT THAT MAY BE PROVIDED BY SENSATA.

Mailing Address: Sensata Technologies, Inc., 529 Pleasant Street, Attleboro, MA 02703, USA

CONTACT US

Sensata Technologies
 Jan Tinbergenstraat 80
 7559 SP Hengelo
 The Netherlands
 1-508-236-3800
 +44 (0)1202 897969
cynergy3.enquiries@sensata.com