



Model	Output Current	Input Current	Input Power	Output Power Range	PF	Efficiency	Output Voltage	No load Voltage
RC15W300A9	300mA	0.1A	19W	10.8-15W	0.9	85%	36-50V	63V
RC15W350A9	350mA	0.09A	17W	9.45-14W	0.9	85%	27-40V	55V
RC15W400A9	400mA	0.11A	20W	9.6-16W	0.9	85%	27-40V	55V
RC15W500A9	500mA	0.1A	19W	9.5-15W	0.9	85%	19-30V	55V
RC15W700A9	700mA	0.1A	18.5W	9.1-14.7W	0.9	85%	13-21V	35V
RC20W450A9	450mA	0.12A	22.5W	12.15-18W	0.92	86%	27-40V	55V
RC20W500A9	500mA	0.13A	24.5W	13.5-20W	0.95	86%	27-40V	55V
RC20W700A9	700mA	0.13A	26W	13.3-21W	0.95	86%	19-30V	45V
RC24W550A9	550mA	0.14A	27W	14.85-22W	0.95	87%	27-40V	55V
RC24W600A9	600mA	0.15A	29W	16.2-24W	0.95	87%	27-40V	55V

* Test result @230V, 50Hz, Full Load.

1. Parameters

Category	Item	Technical Norm
Features	Output Type	Constant Current
	IP Grade	IP44
	Insulation Class	Class II
Input	Rated Input Voltage	220-240VAC
	Range of Input Voltage	198-264VAC or 220-280VDC
	Frequency	50/60Hz
	Input Current	≤0.15A
	Input Power	≤ 29W
	Power Factor	≥0.9 (230VAC, full load)
	THD	≤15% (230VAC, full load)
	No-load Power Consumption	≤0.5W @230VAC
Output	Current Accuracy	±5%
	Max. Output Power	24W
	Started Delay Time	≤0.5S (230VAC, full load)
	Current Ripple(< 120 Hz)	±5% (Imax-Imin) / (Imax+Imin)
	PstLM	≤1

	SVM	≤0.4
Protection	Short Circuit Protection	Auto Recovery
	Overload Protection	Auto Recovery
	No-load Protection	/
	Insulation voltage	3750V 5mA 60S between P-S
	Insulation resistance	>100M ohm @ 500VDC
	Leakage current	I/P to O/P < 250 μ A
Environment	Ta/Operation Temperature	-20....+60℃
	Ts/Storage Temperature	-40....+85℃
	Tc/Enclosure Temperature	90 ℃
	Humidity	10%....90%RH
	Atmosphere	86-108KPa
Construction	Connection Method	Direct Lead
	Installation	Built-in
	PRI Wire preparation	0.5-1.5 [□]
	SEC Wire preparation	0.5-1.5 [□]
	Dimension	Φ51X22.5mm (R*H)
Standards	Certification	TUV/SAA/CCC/CE/CB
	Safety Standards	EN61347-1:2015,EN61347-2-13:2014/A1:2017, AS 61347.2.13:2018,AS/NZS 61347.1:2016 Inc A1
	EMC Standards	EN IEC 55015:2019EN, IEC 55015:2019/A11:2019 ,EN IEC 61000-3-2:2019,EN 61000-3-3:2013/A1: 2019,EN61547:200
	Performance	EN62384
	Surge	L-N/2KV
Others	RoHS	complied to 2011/65/EU
	Life Time	50,000h @Ta=60℃
	Warranty	5years
	Noise	≤20dB @Background noise ≤15dB , Interval≥20cm
Remark 1.All Parameters, if not specified, are measured at 230VAC/50Hz and 25℃ ambient temperature. 2.LED Driver is a component of the luminaires, Luminaires and wire layout will affect the EMC, please check the EMC with end products again.		

2. Connected quantities of different current Breaker

TYPE	RC15W300A9 Connected quantities of different current Breaker						Input Voltage	Inrush Current	Time
	current (A)	10	13	16	20	25			
	Installation wire diameter	1.5mm ²	2.5mm ²	2.5mm ²	4mm ²	4mm ²			
TYPE B	23	30	37	46	58	@230VAC	26	8.2us	
TYPE C	37	48	59	74	92				
TYPE D	59	77	95	118	148				

TYPE	RC15W350A9 Connected quantities of different current Breaker						Input Voltage	Inrush Current	Time
	current (A)	10	13	16	20	25			
	Installation wire diameter	1.5mm ²	2.5mm ²	2.5mm ²	4mm ²	4mm ²			
TYPE B	23	30	37	46	58	@230VAC	26	7.1us	
TYPE C	37	48	59	74	92				
TYPE D	59	77	95	118	148				

TYPE	RC15W400A9 Connected quantities of different current Breaker						Input Voltage	Inrush Current	Time
	current (A)	10	13	16	20	25			
	Installation wire diameter	1.5mm ²	2.5mm ²	2.5mm ²	4mm ²	4mm ²			
TYPE B	22	29	35	44	55	@230VAC	27.3	4.3us	
TYPE C	35	46	56	70	88				
TYPE D	56	73	90	113	141				

TYPE	RC15W500A9 Connected quantities of different current Breaker						Input Voltage	Inrush Current	Time
	current (A)	10	13	16	20	25			
	Installation wire diameter	1.5mm ²	2.5mm ²	2.5mm ²	4mm ²	4mm ²			
TYPE B	21	28	34	43	53	@230VAC	28.2	5.8us	
TYPE C	34	44	54	68	85				
TYPE D	54	71	87	109	136				

TYPE	RC15W700A9 Connected quantities of different current Breaker						Input Voltage	Inrush Current	Time
	current (A)	10	13	16	20	25			
	Installation wire diameter	1.5mm ²	2.5mm ²	2.5mm ²	4mm ²	4mm ²			
TYPE B	20	26	32	39	49	@230VAC	30.4	5.4us	
TYPE C	32	41	51	63	79				
TYPE D	51	66	81	101	126				

TYPE	RC20W450A9 Connected quantities of different current Breaker						Input Voltage	Inrush Current	Time
	current (A)	10	13	16	20	25			
	Installation wire diameter	1.5mm ²	2.5mm ²	2.5mm ²	4mm ²	4mm ²			
TYPE B	20	25	31	39	49	@230VAC	30.7	3.8us	
TYPE C	31	41	50	63	78				
TYPE D	50	65	80	100	125				

TYPE	RC20W500A9 Connected quantities of different current Breaker						Input Voltage	Inrush Current	Time
	current (A)	10	13	16	20	25			
	Installation wire diameter	1.5mm ²	2.5mm ²	2.5mm ²	4mm ²	4mm ²			
TYPE B	19	25	31	38	48	@230VAC	31.2	5.2us	
TYPE C	31	40	49	62	77				
TYPE D	49	64	79	98	123				

TYPE	RC20W700A9 Connected quantities of different current Breaker						Input Voltage	Inrush Current	Time
	current (A)	10	13	16	20	25			
	Installation wire diameter	1.5mm ²	2.5mm ²	2.5mm ²	4mm ²	4mm ²			
TYPE B	18	24	29	36	45	@230VAC	33	4.6us	
TYPE C	29	38	47	58	73				
TYPE D	47	61	74	93	116				

TYPE	RC24W550A9 Connected quantities of different current Breaker						Input Voltage	Inrush Current	Time
	current (A)	10	13	16	20	25			
	Installation wire diameter	1.5mm ²	2.5mm ²	2.5mm ²	4mm ²	4mm ²			
TYPE B	19	25	31	39	49	@230VAC	30.8	6.3us	
TYPE C	31	41	50	62	78				
TYPE D	50	65	80	100	125				

TYPE	RC24W600A9 Connected quantities of different current Breaker						Input Voltage	Inrush Current	Time
	current (A)	10	13	16	20	25			
	Installation wire diameter	1.5mm ²	2.5mm ²	2.5mm ²	4mm ²	4mm ²			
TYPE B	19	25	31	38	48	@230VAC	31.3	4.7us	
TYPE C	31	40	49	61	77				
TYPE D	49	64	79	98	123				

3. Label



4. Electrical values

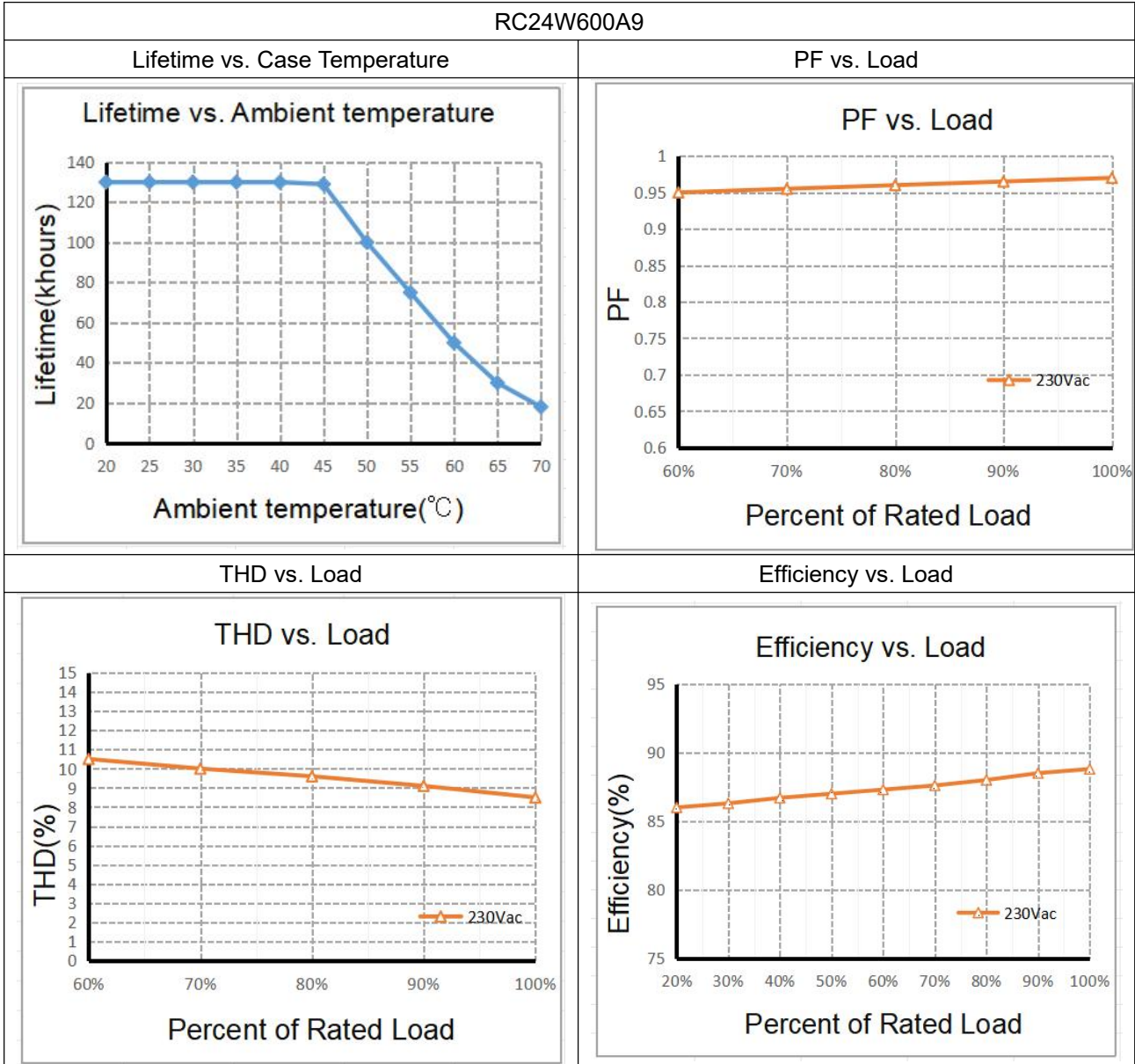

5. Dimension (Unit: mm)

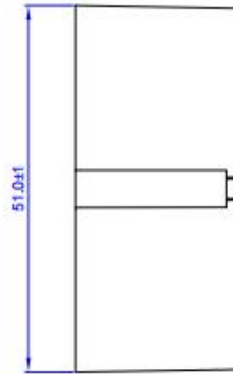
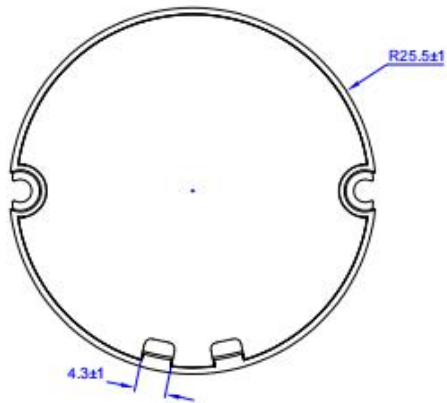
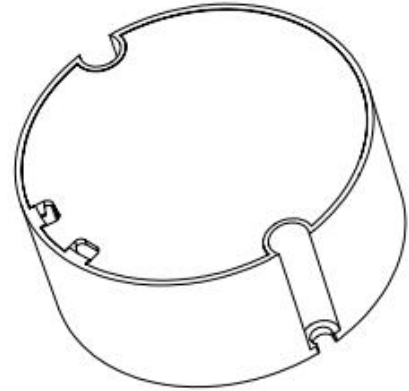

6. Packing information

Carton L*W*H(mm)	Pcs/Carton	Net weight/ Pcs(kg)	Net weight/ Carton(kg)	Gross weight / Carton(kg)
410*270*160	120	0.075	9	12

7. Wiring Diagram

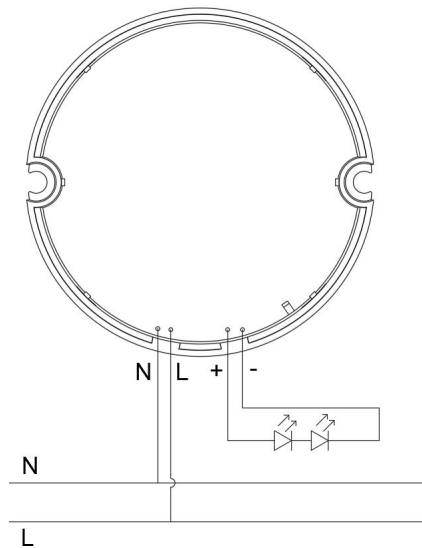

8. Wiring instructions

- All connections must be kept as short as possible to ensure good EMI behaviour
- Mains leads should be kept apart from LED Driver and other leads (ideally 5 – 10 cm distance)
- Advice the maximum length of output wires is 3 m
- Secondary switching is not permitted (Except for constant voltage)
- Incorrect wiring can damage LED modules.
- The wiring must be protected against short circuits to earth (sharp edged metals parts, metal cable clips, louver, etc.)

9. REVISION HISTORY

DATE	VER	REMARK
2024-6-18	V1.0	Initial release.