



DC COMPONENTS CO., LTD.

DISCRETE SEMICONDUCTORS

BC547

TECHNICAL SPECIFICATIONS OF NPN EPITAXIAL PLANAR TRANSISTOR

Description

Designed for use in driver stage of audio amplifier.

Pinning

- 1 = Collector
- 2 = Base
- 3 = Emitter

Absolute Maximum Ratings(T_A=25°C)

Characteristic	Symbol	Rating	Unit
Collector-Base Voltage	V _{CB0}	50	V
Collector-Emitter Voltage	V _{CE0}	45	V
Emitter-Base Voltage	V _{EB0}	6	V
Collector Current	I _C	100	mA
Total Power Dissipation	P _D	500	mW
Junction Temperature	T _J	+150	°C
Storage Temperature	T _{STG}	-55 to +150	°C

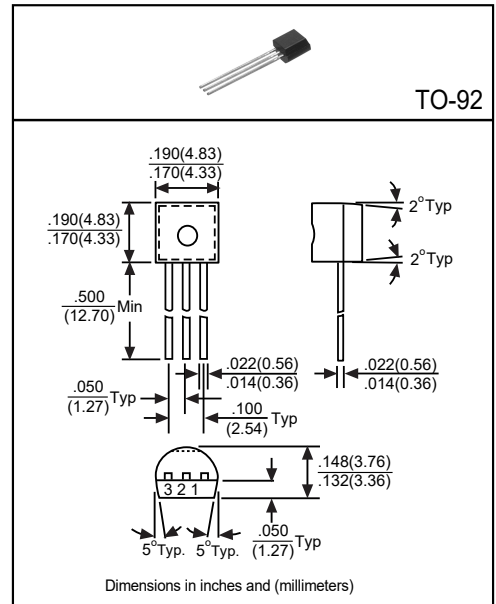

Electrical Characteristics

(Ratings at 25 °C ambient temperature unless otherwise specified)

Characteristic	Symbol	Min	Typ	Max	Unit	Test Conditions
Collector-Base Breakdown Voltage	BV _{CB0}	50	-	-	V	I _C =100μA, I _E =0
Collector-Emitter Breakdown Voltage	BV _{CE0}	45	-	-	V	I _C =1mA, I _B =0
Emitter-Base Breakdown Voltage	BV _{EB0}	6	-	-	V	I _E =10μA, I _C =0
Collector Cutoff Current	I _{CBO}	-	-	15	nA	V _{CB} =30V, I _E =0
Collector-Emitter Saturation Voltage ⁽¹⁾	V _{CE(sat)1}	-	-	0.25	V	I _C =10mA, I _B =0.5mA
	V _{CE(sat)2}	-	-	0.6	V	I _C =100mA, I _B =5mA
Base-Emitter Saturation Voltage ⁽¹⁾	V _{BE(sat)1}	-	0.7	-	V	I _C =10mA, I _B =0.5mA
	V _{BE(sat)2}	-	0.9	-	V	I _C =100mA, I _B =5mA
Base-Emitter On Voltage	V _{BE(on)1}	0.58	-	0.7	V	I _C =2mA, V _{CE} =5V
	V _{BE(on)2}	-	-	0.77	V	I _C =10mA, V _{CE} =5V
DC Current Gain ⁽¹⁾	h _{FE}	110	-	800	-	I _C =2mA, V _{CE} =5V
Transition Frequency	f _T	-	300	-	MHz	I _C =10mA, V _{CE} =5V, f=100MHz
Output Capacitance	C _{ob}	-	-	4.5	pF	V _{CE} =10V, f=1MHz, I _E =0

(1)Pulse Test: Pulse Width ≤ 380μs, Duty Cycle ≤ 2%

Classification of h_{FE}

Rank	A	B	C
Range	110~220	200~450	420~800