

Product Specification

Number: L-KLS9-TN-3714-80-6P
Name: LEDs
Specification: _____
Customer: _____
Date: 2024-08-23

Customer Signature:



NINGBO KLS ELECTRONIC CO; LTD
Tel : 0086-574-86828566
Fax : 0086-574-86824882
ADD : NO. 8-1, RONGXIA RD. XIAPU SHANQIAN
INDUSTRIAL ZONE BEILUN NINGBO ZHEJIANG.

Compile	Check	Review	Approval
Jenny	Jack.C		

Content

Content	2
1.General Specifications	3
2. Pin Assignments	4
3. Outline Drawing	5
4. Dc Characteristics	6
5. AC Characteristics	6
6. Functional Description	7
7. LCD PRODUCTION INSPECT STANDARD	9
8.Content of Reliability Test	14
9. APPLICATION NOTES	15

1.General Specifications

Display type: TN

Polarizer mode: REFLECTIVE/POSITIVE

Viewing Angle: 12:00

Driving Method: STATIC

LCD operation voltage: VDD=3.0V, Vop=3.0V(typ.)

Controller: ML1001-2U

Operating Temperature: -20°C ~+70°C

Storage Temperature: 30°C ~+80°C

Outline Dimensions: Refer to outline drawing on next page

Weight: TBD

Note 1: Please refer to the mechanical drawing.

Note 2: Luminance is measured with touch panel attached.

2. Pin Assignments

Pin No.	Symbol	Function
1	VDD	Supply voltage
2	GND	Logic ground
3	LOAD	Load data from the shift register to data register
4	DIN	Display data input pin
5	LCLK	Input pin to the LCD display clock
6	DCLK	Input pin for the clock of the display data

3. Outline Drawing

<p>APPROVED BY: _____</p>	<p>Ver _____</p> <p>Date _____</p> <p>Modify Contents _____</p>	<p>MAX 2.85 1.10±0.10 1.10±0.10 0.30±0.03 20.00±0.50</p> <p>MIN 0.80 MAX 5.00 MIN 8.40</p> <p>37.00±0.20 MIN V.A 34.00</p> <p>MIN V.A 5.50 7.80±0.20 0.90 0.90</p> <p>PITCH 1.80*(6-1)=9.00±0.20</p> <p>FRONT 0.50±0.40(2X) BACK ±5° 0.50±0.05</p>
---------------------------	---	--

PIN	SIGNAL
1	VDD
2	GND
3	LOAD
4	DIN
5	LCLK
6	DCLK

PIN COM1	S1	S2	S3	S4	S5	S6	S7	S8	S9	S10	S11	S12	S13	S14	S15
PO	OB	OC	OD	OE	OF	OG	OH	OA	OB	OC	OD	OE	OF	OG	OH
PI	PI	PI	PI	PI	PI	PI	PI	PI	PI	PI	PI	PI	PI	PI	PI
2A	2B	2C	2D	2E	2F	2G	2H	2I	2J	2K	2L	2M	2N	2O	2P
3A	3B	3C	3D	3E	3F	3G	3H	3I	3J	3K	3L	3M	3N	3O	3P
4A	4B	4C	4D	4E	4F	4G	4H	4I	4J	4K	4L	4M	4N	4O	4P
5A	5B	5C	5D	5E	5F	5G	5H	5I	5J	5K	5L	5M	5N	5O	5P
6A	6B	6C	6D	6E	6F	6G	6H	6I	6J	6K	6L	6M	6N	6O	6P
7A	7B	7C	7D	7E	7F	7G	7H	7I	7J	7K	7L	7M	7N	7O	7P
8A	8B	8C	8D	8E	8F	8G	8H	8I	8J	8K	8L	8M	8N	8O	8P

NOTE:

- GENERAL TOLERANCE: ±0.2mm
- THE PART OF *ARE THE KEY DIMENSION TO CONTROL

LCD TYPE	TN	BACKLIGHT COLOR	*****
POLARIZER TYPE	REFLECTIVE	FRAME TYPE	*****
DISPLYA TYPE	POSITIVE	DATA TRANSFER	*****
LCD COLOR	*****	CONNECTOR TYPE	PIN
VIEWING ANGLE	12:00	TECHNOLOGY	COG
OPERATING TEMP	-20°C ~ +70°C	DC-DC IC	*****
STORAGE TEMP	-30°C ~ +80°C	LCD DUTY	STATIC
BACKLIGHT TYPE	*****	LCD BIAS	*****
CONTROLLER IC	ML1001-2U		RoHS
REMARKS	VDD=3.0V, VLCD=3.0V(typ.)		

PRODUCT NO.		SCALE	1:1	REV.	V01
DRAWN BY		PAGE	1/4		
CHECKED BY		UNIT	mm		
APPROVED BY					

4. Dc Characteristics

V_{DD} = 3.0V; T_{amb} = 25°C; unless otherwise specified

Parameter	Symbol	Condition	MIN	TYP	MAX	Unit
Supplies						
Supply voltage	V _{DD}		2.0	-	6.0	V
Supply Current	I _{DD}	Disable Oscillator	-	0.1	0.5	uA
Supply Current	I _{DD}	Enable Oscillator	-	25	60	uA
Logic						
LOW-level input voltage	V _{IL}		GND	-	0.3*V _{DD}	V
HIGH-level input voltage	V _{IH}		0.7*V _{DD}	-	V _{DD}	V
LOW-level output current	I _{OL}	V _{OL} = 1.0V	1	-	-	mA
HIGH-level output current	I _{OH}	V _{OH} = 2.0V	-1	-	-	mA
LCD outputs						
Output resistance at pads S1 to S40	R _{SEG}		-	85	150	ohm
Output resistance at pads COM1A and COM1B	R _{COM}		-	45	100	ohm

5. AC Characteristics

V_{DD} = 3.0V; T_{amb} = 25°C; unless otherwise specified

Parameter	Symbol	Conditions	MIN	TYP	MAX	Unit
Oscillator frequency at pad OOUT	f _{oout}		21	32	48	kHz
FIN, LOAD, DIN, DCLK High time	t _H		0.4	-	-	us
FIN, LOAD, DIN, DCLK Low time	t _L		0.4	-	-	us
FIN, LOAD, DIN, DCLK Rise time	t _r		-	-	10	us
FIN, LOAD, DIN, DCLK Fall time	t _f		-	-	10	us
DCLK Frequency	F _{DCLK}		1	-	100	kHz
Baudrate	B _{PSDCLK}		1	-	500	kbps

Timing Diagram

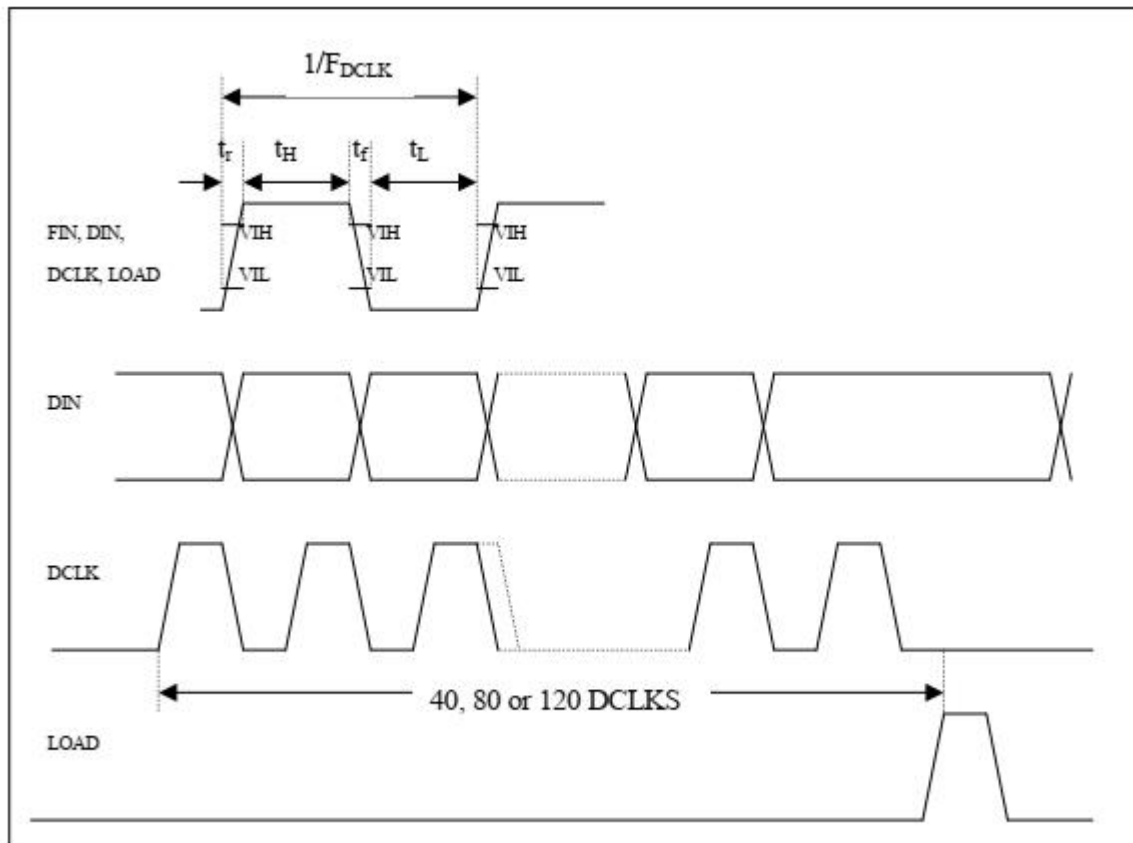

6. Functional Description

The ML1001 is a static LCD COG (chip on glass) driver which can drive upto 40 segments or cascaded with two or three ML1001s to drive 80 & 120 segments. There is a shift register for serially shifting in the data and a data register to store the data that is going to be displayed. The display data is read into the shift register serially through the DIN pin at the rising edge of the DCLK signal. The display data will then be displayed at the rising edge of the LOAD signal. The display data in the shift register is output by the DOUT pin after 40 rising edges of the DCLK signal. The display data should be input in the sequence of SEG40, SEG39... SEG2, SEG1 for proper display of data.

i) Power on reset

At Power on the ML1001 resets to a starting condition as follows:

1. The shift register outputs are set to GND.
2. The data register outputs are set to GND, hence all LCD segments off.

ii) Oscillator

a) Internal clock

The internal logic and the LCD driving signal of ML1001 are clocked either by the built-in oscillator or from an external clock. When the internal oscillator is used, OEN should be connected to GND and the OOUT should be connected to FIN. The oscillator will oscillate at 32 kHz and the frequency is independent in the range of $2.0V < V_{DD} < 6.0V$.

b) External clock

When using an external clock, the OEN is connected to VDD then connects the external clock to FIN.

iii) Timing

ML1001 have several frequencies of clock signal for the users to choose for the LCD display clock (ie. LCLK) and the blink clock (ie. BCLK). They include the following clock signals :

NINGBO KLS ELECTRONIC CO; LTD

Frequency of Clock Signal at FIN = 32 kHz	Actual Divider of FIN	Target Input Pin
2 KHz	1/16	LCLK
1 KHz	1/32	
500 Hz	1/64	
256 Hz	1/128	
128 Hz	1/256	
4 Hz	1/8192	BCLK
2 Hz	1/16384	
1 Hz	1/32768	

iv)

Segment outputs

ML1001 has 40 segment outputs which should be connected directly to the LCD. If less than 40 segments are required, the unused segments should be left open circuit. Users can disable the first 1 to 16 segments and the last 17 to 40 segments by connecting the SEN1 and SEN2 to VDD, respectively. The segment outputs shall output GND level after disabling it.

v) Common outputs

ML1001 consists of 2 common signals (ie. COM1A & COM1B). These two common signals are the inversion of the LCLK. The common outputs should be left open-circuit if the outputs are unused. Users can disable the COM1A and COM1B by connecting the CEN1A and CEN1B to VDD, respectively. The common outputs will change to GND after disabling it.

vi) Blink

ML1001 has a blink function that users shall connect the BEN to GND and input the blink clock (ie. BCLK) either by connecting ML1001 output clock signal from Frequency Divider or an external clock signal. Users shall disable blink function by connecting BEN to VDD.

7. LCD PRODUCTION INSPECT STANDARD

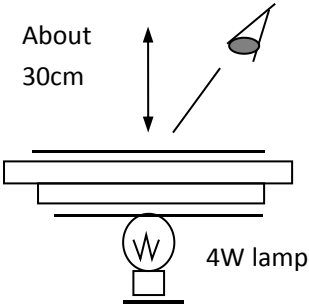
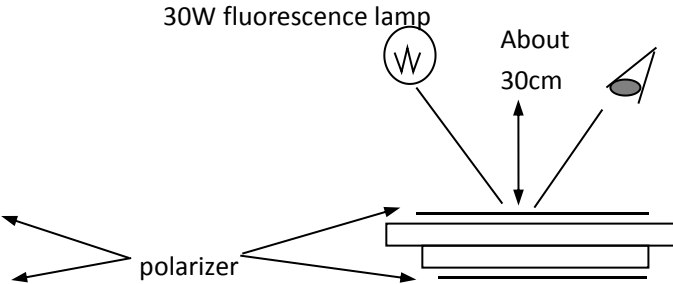
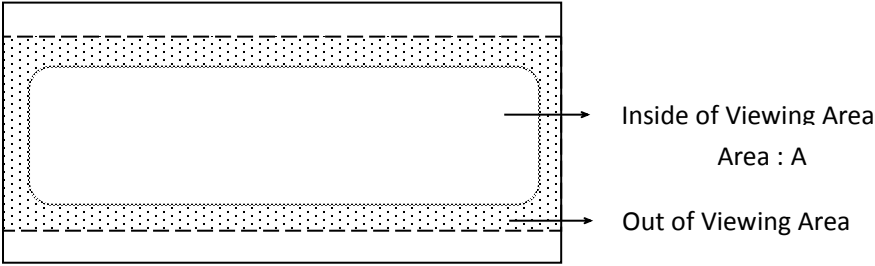
Item	Content
1. Purpose	In order to ensure GV's production quality
2. Apply range	This inspect standard is adapted to production's size, appearance, electric capability etc. But, content that out of inspection standard isn't exclude
3. Units	One display piece or one batch production
4. Inspect system	<p>A/ Inspect in produce process and before shipment is included in Inspect system;</p> <p>B/ Inspect in produce process is a process that inspect appearance, electric capability when production is producing;</p> <p>C/ Inspect before shipment is a process that take out part production, After produce process inspect and before leave factory.</p> <p>D/ Standard that take out part production inspect is refer to ANSI/ASQC Z1.4 (MIL-STD-105E);</p> <p>E/ AQL value: grave defect according to 0.65 , small defect according to 1.0</p>
5. Inspect condition	<p>A/ Inspect equipment: inspect apparatus and tool;</p> <p>B/ Inspect conditions: as follows illustrate.</p> <div style="display: flex; justify-content: space-around; align-items: center;"> <div style="text-align: center;">  <p>illustrate one Transmissive type</p> </div> <div style="text-align: center;">  <p>illustrate two Reflective type</p> </div> </div> <div style="margin-top: 20px;">  <p style="text-align: center;">illustrate three</p> </div>

NINGBO KLS ELECTRONIC CO; LTD

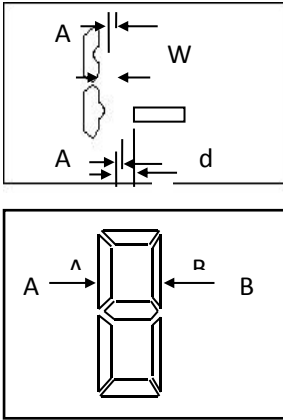
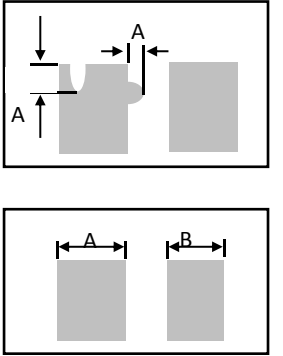
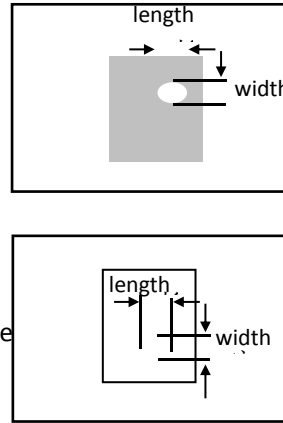
Segment distortion		concave protrude $A \leq 0.15$ coarse $(A-B) \leq 0.15$ RE: protrude point ≤ 0.15 and $\leq 1/2d$ Concave point ≤ 0.15 and $\leq 1/3w$ If width $\leq 0.3\text{mm}$ then can't error (must precision)	puniness	Eye observe magnifier	A								
Segment distorte		concave protrude $A \leq 0.15$ coarse thin $(A-B) \leq 0.15$ RE: border upon segment can't connect	puniness	Eye observe magnifier	A								
Black & white dot pour		Black and white dot pour <table border="1" style="margin-left: auto; margin-right: auto;"> <thead> <tr> <th>D</th> <th>accept amount</th> </tr> </thead> <tbody> <tr> <td>$D \leq 0.10$</td> <td>unlimited</td> </tr> <tr> <td>$0.10 < D \leq 0.15$</td> <td>3</td> </tr> <tr> <td>$D > 0.15$</td> <td>0</td> </tr> </tbody> </table> RE: only one black & white dot in a segment, each lattice area must hold more than half area. It isn't accepted if five pour appear at one LCD $D = (\text{length} + \text{width}) / 2$	D	accept amount	$D \leq 0.10$	unlimited	$0.10 < D \leq 0.15$	3	$D > 0.15$	0	puniness	Eye observe magnifier	A
D	accept amount												
$D \leq 0.10$	unlimited												
$0.10 < D \leq 0.15$	3												
$D > 0.15$	0												
No display	All design can't emerge		severity	Eye observe	A								
Part display	Design line can't emerge when part display		severity	Eye observe	A								
Display state	Display can't feebleness , excessive and short circuit		severity	Eye observe	A								
Display position	Design display position must be within tolerance of manufacture blue		severity	Eye observe	A								

content	Inspection standard	(mm)	grade	Judge ways	Apply range
---------	----------------------------	------	-------	------------	-------------

NINGBO KLS ELECTRONIC CO; LTD

Cracking

A: General edge cracking

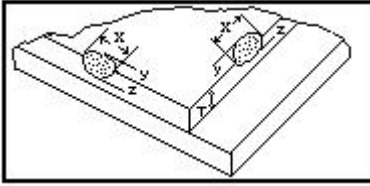

X	Y	Z
unlimited	≤ 0.5	$\leq 1/2t$
≤ 4.0	≤ 1.5	$\leq 1/2t$
≤ 3.0	≤ 1.0	$\leq t$

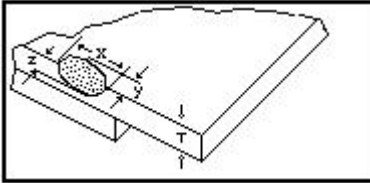

RE: T...odd glass thickness
X...Length; Y...width
Z...height; electrode width;
All crack can't in the view range

purity

Eye magnifier

B

B: terminal's double surface

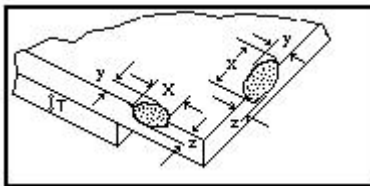

X	Y	Z
unlimited	≤ 0.5	$\leq 1/2t$
≤ 4.0	≤ 2.0	$\leq 1/2t$
≤ 3.0	≤ 1.0	$\leq t$

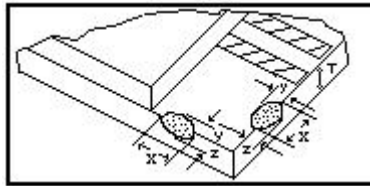

RE: Distance between crack part and Electrode must be large width of electrode.
Otherwise, reference C.

purity

Eye magnifier

B

C: terminal cracking

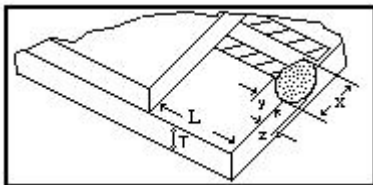

X	Y	Z
unlimited	≤ 0.3	$\leq 1/2t$
≤ 2.0	≤ 0.8	$\leq 1/2t$
≤ 3.0	≤ 0.5	$\leq t$

E: Y value $\leq 1/3L$

purity

Eye magnifier

B

D: Corner cracking

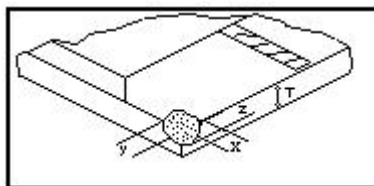

X	Y	Z
≤ 2.0	≤ 2.0	$\leq t$

RE: It should reference C standard if distance between crack and electrode less than one electrode width.

purity

Eye magnifier

B

NINGBO KLS ELECTRONIC CO; LTD

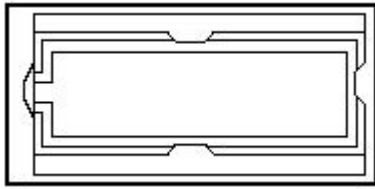

RE: All sealing part narrow because
Of crack should be classified as
defect.

Puniness

Eye magnifier

B

E: Cracking the sealing part

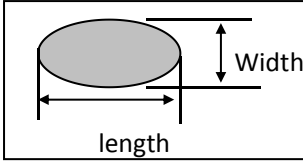
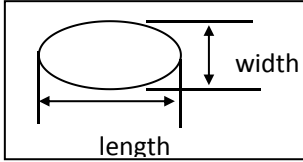
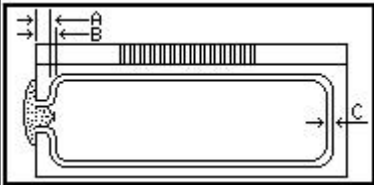
content	Inspection standard	item (mm)	grade	judge ways	apply rage															
Figure size	Accord with figure tolerance that manufacture blueprint regulate		Severity	Vernier caliper	B															
Crack	forbid		Puniness	Eye	A B															
Dark dot White dot Gas froth Feculence Scar	 $D = (\text{length} + \text{width}) / 2$ <table border="1" style="margin-left: auto; margin-right: auto;"> <thead> <tr> <th>D</th> <th>Accept amount</th> </tr> </thead> <tbody> <tr> <td>$D \leq 0.10$</td> <td>unlimited</td> </tr> <tr> <td>$0.1 \leq D \leq 0.20$</td> <td>3</td> </tr> <tr> <td>$D > 0.20$</td> <td>0</td> </tr> </tbody> </table>  <p>RE: if two appear. distance must be Exceed 5mm</p>	D	Accept amount	$D \leq 0.10$	unlimited	$0.1 \leq D \leq 0.20$	3	$D > 0.20$	0		Puniness	Eye magnifier	A							
D	Accept amount																			
$D \leq 0.10$	unlimited																			
$0.1 \leq D \leq 0.20$	3																			
$D > 0.20$	0																			
Scar trace Dark line Dust	<table border="1" style="margin-left: auto; margin-right: auto;"> <thead> <tr> <th>Length</th> <th>Width</th> <th>Acc quantity</th> </tr> </thead> <tbody> <tr> <td>unlimited</td> <td>$T \leq 0.02$</td> <td>Unlimited</td> </tr> <tr> <td>≤ 3.0</td> <td>$T \leq 0.03$</td> <td>2</td> </tr> <tr> <td>≤ 2.0</td> <td>$T \leq 0.05$</td> <td>2</td> </tr> <tr> <td>> 2.0</td> <td>$T > 0.05$</td> <td>0 (Re)</td> </tr> </tbody> </table>	Length	Width	Acc quantity	unlimited	$T \leq 0.02$	Unlimited	≤ 3.0	$T \leq 0.03$	2	≤ 2.0	$T \leq 0.05$	2	> 2.0	$T > 0.05$	0 (Re)		Puniness	Eye Magnifier	A
Length	Width	Acc quantity																		
unlimited	$T \leq 0.02$	Unlimited																		
≤ 3.0	$T \leq 0.03$	2																		
≤ 2.0	$T \leq 0.05$	2																		
> 2.0	$T > 0.05$	0 (Re)																		
Sealing	 <p>B: sealing mouth length. C: sealing circle frame width</p> <ol style="list-style-type: none"> The minimum injection amount of sealant should be $a > 1/3b$, but, can't in view bound. Size of the solidified seal subjects to actual drawing. Sealing circle frame distortion, it would be classified as defect if fact size less than $1/3c$. 		Puniness	Eye Magnifier	B															
Polarizer	Adhibit position should be in the figure tolerance that manufacture blueprint regulate		Puniness	Eye	A B															

NINGBO KLS ELECTRONIC CO; LTD

Color splash	No especially color splash (rainbow)	Punines s	eye	A
content	Standard item (mm)	grade	judge way	apply range
Screen print	Non-allow wrong screen print (screen tool is wrong) or design is reverse	Severity	Blueprint Sample	A
	Screening side shouldn't be used mistake		Blueprint Sample	
	Printing ink shouldn't be used mistake	Severity	Blueprint Sample	
	Color must be accord with sample's desire	Punines s	Hue sample	
	Printing ink is short, screen faintness and design uncomplete all isn't accept	Punines s	eye	
	Screen print design slopeing angle degree, distance size between design edge and LCD edge should accord with blueprint	Punines s	Magnifier	
			Vernier Caliper	
	Dark and white dot on the screen print surface, reference LCD standards	Punines s	Magnifier	
	Word width that screen print on the LCD surface, reference segment distortion standard.	s	Magnifier	
After screen printing ,design can't be dirt and damaged	Punines s	eye		

REMARK:

1: Purchaser quality inspection:

Purchaser should inspect production at once if it have been delivered, and announce inspection result to supplier within 30 days. Otherwise , it means that production have been accepted, and it is eligibility.

2: Feedback treatment

2.1 When purchaser inspected production and judged production defect be attributed to supplier , please untread production to supplier . but , both supplier and customer should analysis the reasons and discuss treatment ways when the defect and liability reason is not sure.

2.2 When customer untread defect production to supplier ,defect phenomena should be point out clearly.

8.Content of Reliability Test

Item		Conditions	Period (hr.)	Sampling method
		General temp range		
High storage temperature		80°C	72	
*High operating temperature		70°C	72	
Low storage temperature		-30°C	72	
Low operating temperature		-20°C	72	
Low operating temperature(with polarizer)	General durability type	40°C/90%RH	72	
Thermal cycles		-20°C /30min←20°C /5min→70°C / 30min	10 cycles	

These test items will be done if required by customer, This item may be replaced by 100°C/100%RH 10hr test in order to save time. Every test items shall meet the following criteria. Judgement should be made only after the LCD is exposed to room temperature for 4 hours.

Criteria of judgement: (1) All segments shall be usually displayed (2) All segments should not be blurred (3) Current consumption should not exceed the double of its original value

9. APPLICATION NOTES

9.1 Safety Instruction:

The liquid in the LCD should not be swallowed or touched .If it accidentally gets on your hands, wash them with water.

9.2. Handing instructions:

The LCD panel is a glass product developed through precision processing and special orientation treatment. If pressure is applied to the panel, therefore, orientation may be disturbed, making it difficult to return to its original condition. It is apt to crack or be broken easily if is dropped or hit to a hard object, particularly around the edges. Attention must be paid to avoid external shock.

9.3. Mounting Instructions:

- a. When connection a LCD panel to circuit board, it is recommended to use a rubber connector or flexible connector. Direct soldering or mechanical connection is not possible .The pin connected type LCD permits soldering of pins.
- b. When mounting a LCD panel on a cabinet, care must be taken not to apply excessive force on the panel with a fingertip. Etc. Otherwise, it may cause an operating failure or will shorten the lifetime of the panel.
- d. DC voltage or driving voltage higher than the specified voltage will reduce the lifetime of the liquid crystal display panel.
- e. The polarizer should be handled with carefully, because it is soft and apt to suffer damage .If a protective panel is attached to the polarizer to avoid damage and contamination, it should be removed just before use as much as possible.
- f. Use a dry, soft cloth to clean the polarizer, if contamination persists, wipe it off with a small amount of petroleum benzine. Avoid using an organic solvent as much as possible.
- g. When attaching with the heat seal or anisotropically conductive film, wipe off with alcohol before use.
- h. LCD is a sensitive component by electrical driving; the electrode couldn't be inconsecutive, otherwise it will cause nstable display.

9.4. Storage Instructions:

- a. Avoid storage in high temperature and high humidity. When long-term storage is required, keep the panels at a temperature of 15°C to 35°C and at a relative humidity of 65% or less.
- b. The LCD unit should be stored in a dark place, do not expose it to direct sunlight or fluorescent Lamp
- c. Note that the presence of water-drops or dew in the LCD panel may deteriorate the polarizer or corrode the electrode.

NOTE.1 DEFINITION OF VIEWING ANGLE AND DIRECTION

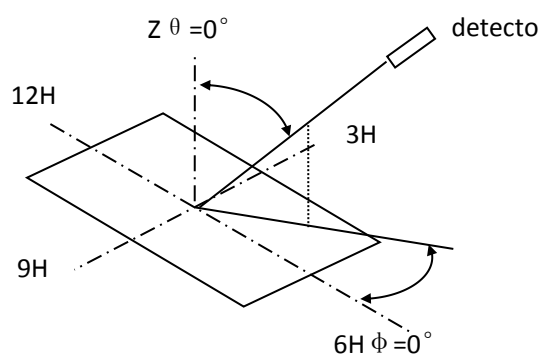

NOTE.2 THRESHOLD VOLTAGE AND SATURATION VOLTAGE

transmission

transmission

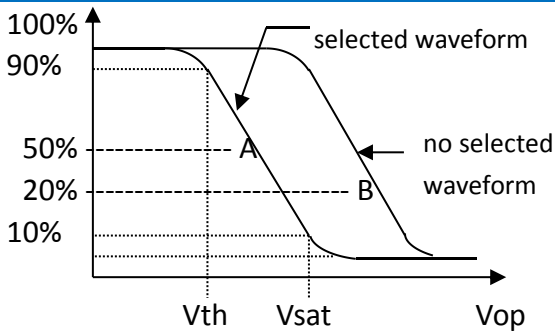

Positive type

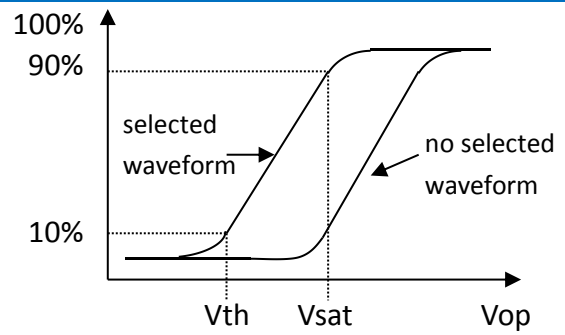

Negative type

V_{th}: The voltage V_{op} that the transmission rate of segment is 90% (positive) or 10%(negative) of saturated value on conditions of the selected waveform. (no-selected waveform is opposition)

V_{sat}: The voltage V_{op} that the transmission rate of segment is 10% (positive) or 10%(negative) of saturated value on conditions of the selected waveform. (no-selected waveform is opposition)

Conditions:

- (1) Temperature: See individual specification.
- (2) Measuring Angle (θ) : See individual specification.
- (3) Driving Frequency : Typical value in individual specification.

NOTE.3 CURRENT CONSUMPTION (I LCD)

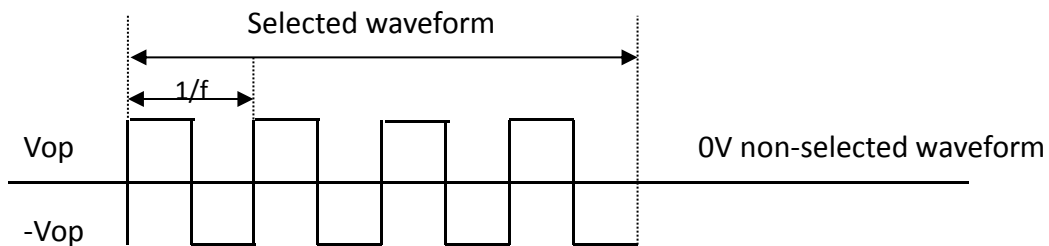

- Conditions:
- (1) Temperature: 25°C.
 - (2) Driving waveform : static waveform
 - (3) Voltage applied to all segments.

NOTE.4 RESPONSE TIME (Tr, Tf)

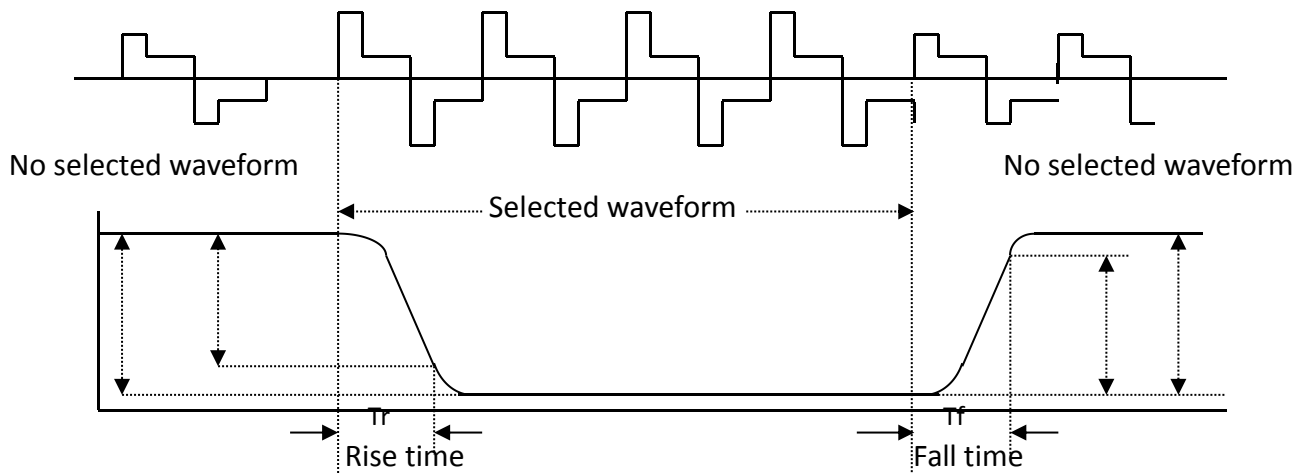

NOTE.5 CONTRAST RATIO (C.R)

5.1 POSITIVE TYPE:

$$\text{CONTRAST RATIO} = \frac{\text{BRIGHTNESS AT VOP (NON-SELECTED)}}{\text{BRIGHTNESS AT VO (SELECTED)}}$$

5.2 NEGATIVE TYPE:

$$\text{CONTRAST RATIO} = \frac{\text{BRIGHTNESS AT VOP (SELECTED)}}{\text{BRIGHTNESS AT VOP (NON-SELECTED)}}$$

NOTE.6 CAPACTANCE (C)

Measuring Method Of Capacitance

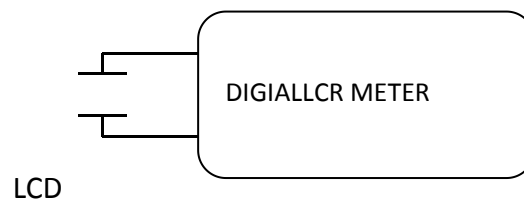

Conditions:

- (1) Temperature: 25°C.
- (2) Driving waveform: 128Hz, sine wave, 5.00v.
- (3) Voltage applied to all segments.