



SPECIFICATION FOR APPROVAL

CUSTOMER: 寧波閃諾

MODEL NO: EC8025HH12BP

CUSTOMER MODEL NO: EC8025HH12BP

DESCRIPTION: DC12V FAN

APPROVED BY (AUTHORISED)	APPROVED
	Alex
	CHECKED
	Xiongwei
	DRAWN
	Chenjie
	SALES
	Serene

* Please confirm your acceptance by return fax or mail.

SPEC NO	ISSUE DATE	EDITION	REVISED DATE
20260413A14	2026/4/13	A0	2026/4/13

THE PRODUCTION ACCORD WITH EUROPE UNION ROHS STANDARD

EVERCOOL THERMAL CO., LTD

NO. 123-8, HSING DE RD., SAN-CHUNG CITY,

TAIPEI HSIEN, TAIWAN, R.O.C.

TEL: 886-2-8512-2889 FAX: 886-2-8512-2890

[URL:www.evercool.com.tw](http://www.evercool.com.tw)

[EMAIL: coolest@ms14.hinet.net](mailto:coolest@ms14.hinet.net)

I. GENERAL SPECIFICATION

Item	Specification	
1.Part NO.	EC8025M12SP	
2.Outline Dimension	80*80*25	
3.Rated Voltage	12	VDC
4.Rated Current*	0.16	A
5.Rated Power Consumption*	1.92	W
6.Rated Speed*	800RPM±25%	2500RPM±10%
7.Airflow**	8.52CFM(ft3/min)	25.02CFM(ft3/min)
8.Static Pressure**	0.01In-H2O	0.08In-H2O
9.Noise Level***	<10dB(A)	<28dB(A)
10.Life Expectancy	25000 hrs at 25°C	
11.No of Polarity	4 Poles	
12.Direction of Rotation	Counter-Clockwise	

Noted:

***Input Current Speed Power Consumption**

Measured after continuous 30 minutes operation at rated voltage in free air at ambient temperature of 25 °C, 65% relative humidity

****Performance**

Measured with use of double chamber. The value are recorded when the fan speed is stabilized at rated voltage.

*****Noise Level**

Measured at rated voltage in a semi-anechoic chamber with background noise below than 20 dB(A). The measuring distance is in one meter from microphone to inlet of the fan.

II. ELECTRICAL SPECIFICATION

Item		Specification
1.Polarity Protection	✓ YES	Be capable of endurance when Vcc & GRD are exchanged
	NO	
2.Auto restart	✓ YES	Locked motor protection
	NO	
3.Insulation Resistance		10MΩ/b/w unshielded wire and frame at 500 VDC/min
4.Dielectric Strength		5Ma Max./Measured b/w lead wire and frame at 500VAC/min

III. MAIN MATERIALS / PARTS SPECIFICATION

Item		Specification				
1.Materials of Frame		Thermoplastic PBT of UL 94V-0(BK)				
2.Materials of Fan Blade						
3.Bobbin						
4.Bearing		Dual ball bearing				
		1 ball & 1 sleeve bearing				
	✓	Sleeve bearing				
		EL bearing				
5.Lead wire	✓	Red (+)	UL#	1571	28	AWG
	✓	Black (-)	UL#	1571	28	AWG
	✓	Yellow(FG)	UL#	1571	28	AWG
	✓	Blue(PWM)	UL#	1571	28	AWG
6.Connector		2510 4P(並線)				

IV. ENVIRONMENT SPECIFICATION

Item	Specification
1.Operation Temperature	-10℃~+70℃/66%(RH), high / low temperature test for 24 hours, temperature change: 30℃/hours.
2.Storage Temperature	-40℃~+70℃/66%(RH), high / low temperature test for 24 hours, temperature change: 30℃/hours.

V. DROPPING TEST

Prepared in minimum packing condition, fan will withstand one drop each on three surfaces from 30 cm height onto a 10mm thick hard wooden board.

VI. LABEL MARKING



VII. OUTLINE DIMENSION

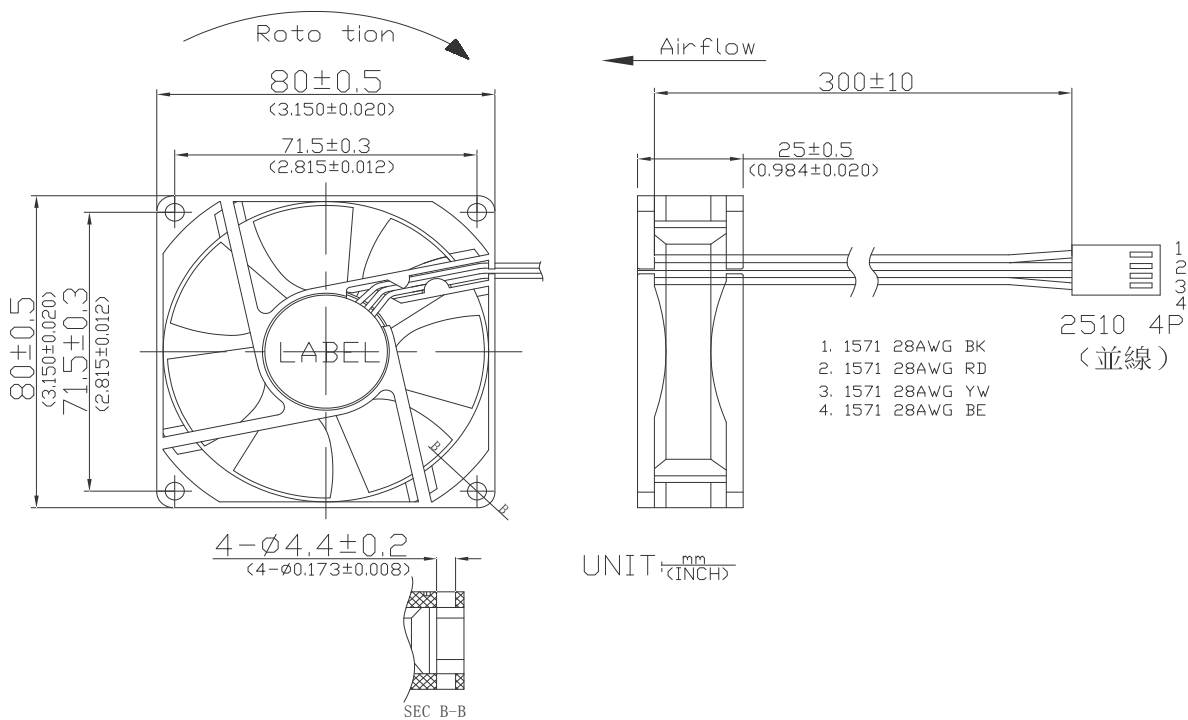

VIII.PWM CONTROL SIGNAL:
Signal Voltage Range:-0.8-20VDC.

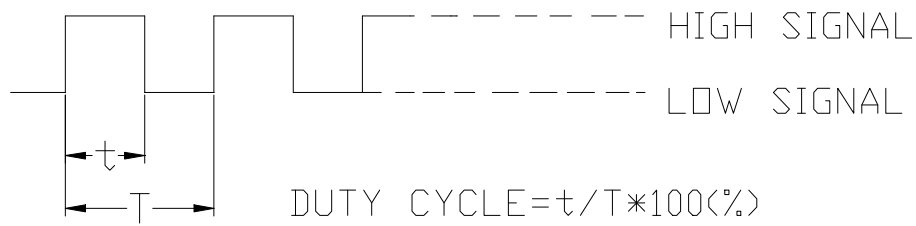

The frequency for control signal of the fan shall be able to accept a 18KHZ-32KHZ.

The preferred operating point for the fan is 25k HZ.

At 100% duty cycle ,The rotor will spin at maximum speed.

At 0% duty cycle , The rotor will spin at minimum speed.

The motor speed at different duty cycle is shown in the table below.

SPEED VS PWM CONTROL SIGNAL:

(AT RATED VOLTAGE & PWM FREQUENCY=25KHZ)

DUTY CYCLE(%)	SPEED.PWM(REF)	CURRENT(A)TYP
100	2500±10%	0.16
75	2200±10%	0.1
50	1600±15%	0.08
25	1100±20%	0.06
0	800±25%	0.05

IX. Sensor Curcuit System

PWM CONTROL

In PWM speed control, a fixed frequency square wave is applied to the speed control lead wire of the fan. The ratio of the on time vs. the PWM period is proportional to the RPM.

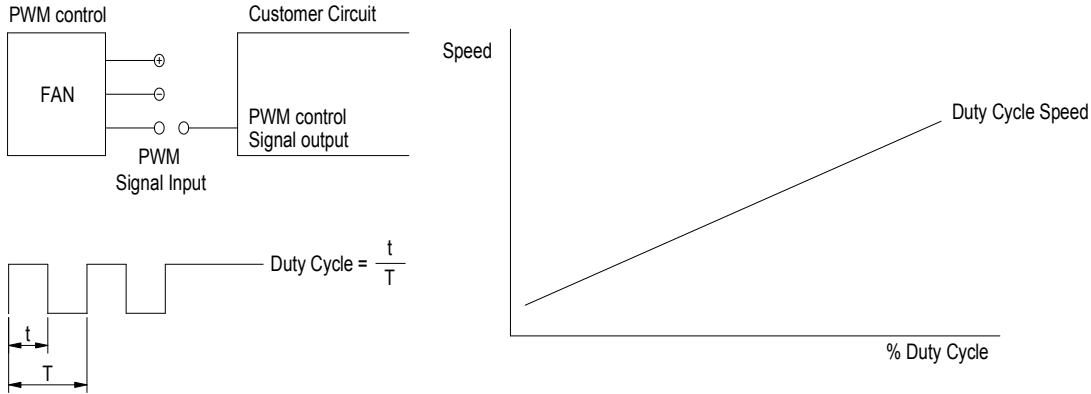

PWM INPUT VOLTAGE RANGE:

High level= 2.8 to 20 VDC
 Low level= 0 to 0.4 VDC

PWM INPUT CURRENT (IPWM) RANGE:

40uA to 20mA

To control signal line of the fan shall be able to accept a 30Hz to 30kHz.
 The preferred operating point for the fan is 0%~100% of duty cycle.

X.Fan Duty Cycle Vs RPM Curve

8025duty cycle vs rpm curve
 RPM

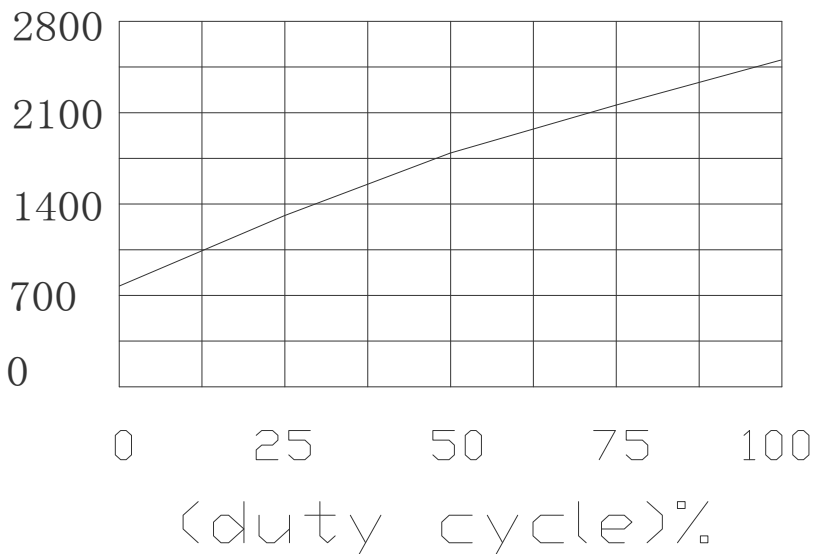

XI. Sensor Circuit System

Speed Sensor / Tachometer (FG/F)

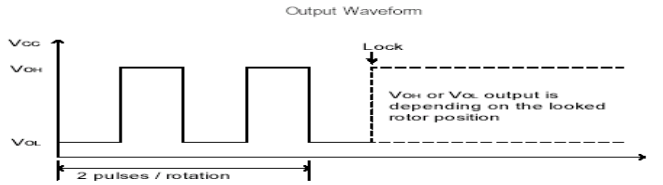
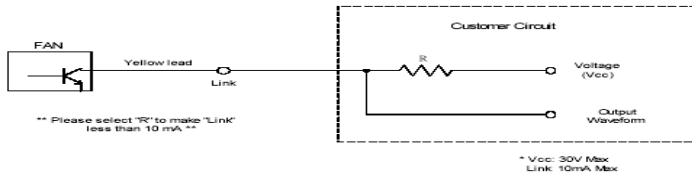

XII. P/Q Performance

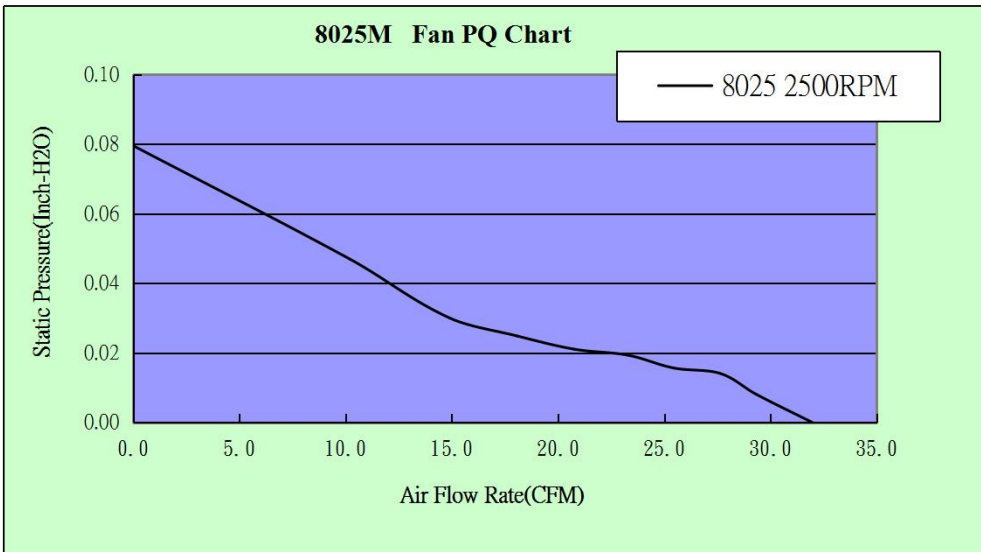

	Q(cfm)	Ps(InchH2o)
1	0.000	0.079
2	8.213	0.052
3	11.641	0.039
4	14.450	0.029
5	16.604	0.029
6	18.592	0.027
7	20.347	0.026
8	22.008	0.019
9	23.523	0.011
10	25.018	0.000